

safety

SAFETY FIRST

Safe System Solutions for Automation Technology
Catalog 2019

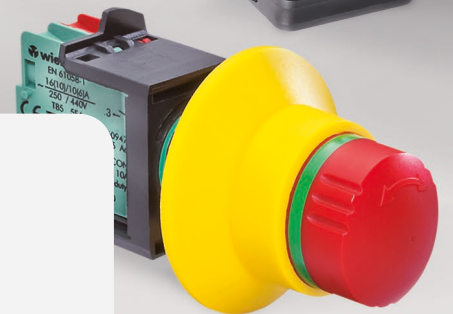

HELLO WIELAND ELECTRIC

Over 100 years of safe connections.

We are the inventor of safe electrical connection technology and are committed to individual and safe system solutions.

Together with our broad product portfolio we offer comprehensive services for industry applications as well as building installation and lighting technology.

All our experience amounted to us being the global market leader for pluggable, electrical installation in commercial buildings and competent partner for machine safety. Our solutions are designed for you to be safe and secure. At the same time, we ensure you that you integrate our systems fast and easy. This saves you time and costs. Thanks to our modular solutions your requirements can be executed failsafe, fast and flexible.

We do business worldwide with subsidiaries, production facilities and sales partners and have an excellent global network. Our teams are supporting customers and projects on all continents – personally and individually. Our competences in engineering, production and logistics processes are interlinked with each other for maximum efficiency.

We are looking forward to be your partner.



1910

founded in
Bamberg



1600+

employees
worldwide



6

production
sites



70+

countries
worldwide

CONTENTS



samos® PRO	Preface	samos® PRO COMPACT	8		
		samos® PLAN 6	Programming tool	10	
		SP-COP1 / SP-COP2	Controller Module	14	
		SP-SDIO / SP-SDI	Input / Output Module	16	
		SP-SAR / SP-SAC / SP-SACR	Analog Module	18	
		SP-DIO	Standard Input / Output Module	19	
			Gateway	20	
		Accessories	22		
samos®	Preface		24		
		SA-BM	Basic Module	28	
		SA-IN	Input Module	29	
		SA-OR-S1 / SA-OR-S2	Relais Output Module	30	
		Gateway	31		
safe RELAY	Preface		32		
	Overview		34		
	Basic Device	SNO 4083KM	Monitoring of emergency stop, safety gates and light barriers	38	
		SNO 4062K / KM	Monitoring of emergency stop, safety gates and light barriers	40	
		SNO 4063K / KM	Monitoring of emergency stop, safety gates and light barriers	42	
		SNA 4043K / KM / KE, SNA 4044K / KM	Monitoring of emergency stop, safety gates and light barriers	44	
		SNA 4063K / KM, SNA 4064 K / KM	Monitoring of emergency stop, safety gates and light barriers	46	
		SNO 4003K	Monitoring of emergency stop + safety gates	48	
		SNO 1012K	Monitoring of emergency stop + safety gates	50	
		SNS 4074K / SNS 4084K	Standstill monitor	52	
		SVM 4001K	Standstill monitor	54	
		SNT 4M63K	Monitoring of emergency stop + safety gates	56	
		SNZ 4052K	Two-hand relay type IIC	58	
		SNZ 1022K	Two-hand relay type IIA	60	
		Basic Device with time function	SNV 4063KL	Monitoring of emergency stop, safety gates and light barriers, OFF-delayed	62
			SNV 4063KP	Monitoring of emergency stop, safety gates and light barriers, ON-delayed	64
	SNV 4074SL / SNV 4076SL		Monitoring of emergency stop, safety gates and light barriers, OFF-delayed	66	
	SNV 4274 SL / SNV 4074ST		Monitoring of emergency stop, safety gates and light barriers, OFF-/ON-delayed	68	
	Safe Contact Expansion Relay	SNE 1	Contact Expansion	70	
		SNE 4003K	Contact Expansion	72	
		SNE 4004K / KV	Contact Expansion	74	
		SNE 4012K / SNE 4024K	Contact Expansion	76	
		SNE 4028S	Contact Expansion	78	
	sensor PRO	Preface		80	
		Light curtains / light grids	SLC	Safety light curtain	82
			SLD	Safety light grid	88
				Accessories	94
Rotary encoder		SENC	Safe HTL incremental encoder	104	
Emergency stop		SNH	Emergency stop button	106	
Safety switch		SIN	Safety switch with guard locking	112	
		SMS	Safety switch with separate actuator	116	
Position switch		SLS	Mechanical safety switches	120	
Transponder switch		STS	Non-contact safety switches	124	
			Accessories	128	
Magnetic switch		SMA	Magnetic safety switch	130	
Interface		SMI 1001	Magnetic switch interface	134	
Complete solutions for machinery and plant engineering		Graphic art	136		
Support		Software, Training, Hotline	138		
Glossary		Explanation on the overview	140		

safety

samos® PRO

samos®

safe RELAY

sensor PRO





OVERVIEW OF SAFETY TECHNOLOGY

From the safety sensors of the **sensor** PRO series through the **safe** RELAY safety relays and the modular, with the screwdriver configurable, safety modules **samos**® to the programmable modular safety control **samos**® PRO you always get the suitable product for the protection of man and machine.

Tested technology

Of course, Wieland Electric offers only thoroughly tested and certified safety technology (i.e., all technical safety products have been approved by recognized testing institutes and meet current regulations and standards).



WE OFFER YOU:

- + INTUITIVE SOFTWARE
- + MODULAR SAFETY CONTROLLER
- + COMPACT SAFETY CONTROLLER
- + UNIVERSAL SAFETY RELAYS
- + SAFE SIGNAL DETECTION

SAMOS® PRO COMPACT



SAMOS®



SAFE RELAY



SENSOR PRO



FIT FOR **SAFETY** WITH WIELAND

Wieland supports and advises you – from the planning stage right through to start-up – throughout the entire life cycle of a machine or production system. The broad portfolio of safety switching devices covers all important safety functions and fulfills even complex customer requirements.

IMPORTANT STANDARDS FOR MORE SAFETY

The safety products from Wieland Electric fulfil a number of international standards and regulations with machine and system safety for various applications playing a major role.

SOLUTIONS FOR MANY INDUSTRIES

The safety requirements for machine and system control are becoming more demanding in all areas. Wieland Electric offers tailored, innovative solutions ranging from sensors right down to safety control.

SOLUTIONS:

- + MACHINE BUILDING INDUSTRY
- + PROCESS INDUSTRY
- + PRESSES
- + ELEVATORS AND ESCALATORS
- + CONVEYOR SYSTEMS
- + WIND TURBINES
- + FIRING SYSTEMS



- ▶ EN/IEC 60204-1
- ▶ EN/IEC 61508
- ▶ EN/IEC 62061
- ▶ EN ISO 13849-1
- ▶ EN/IEC 61511

PERFORMANCE LEVEL (PL) ACCORDING TO EN ISO 13849-1

As the successor standard to EN 954-1, EN ISO 13849-1 is based on the known categories. EN ISO 13849-1 deals with the complete safety functions, including all the devices involved in the their design.

EN ISO 13849-1 makes a quantitative assessment of the safety functions. Using the categories as a basis, the so-called Performance Levels (PL) are applied for this purpose.



SAFETY INTEGRITY LEVEL (SIL) ACCORDING TO EN/IEC 61508

In electrical control technology according to EN/IEC 61508, safety requirements can be divided into so-called Safety Integrity Levels (SIL). The risk assessment takes into account the severity of the injury (S), the frequency and duration of the exposure to the hazard (F), the probability of occurrence of a potentially hazardous incident (W), and the possibility of avoiding or limiting the damage (P). Hence, at the highest protection level SIL 3, the safety function must be maintained at all times.

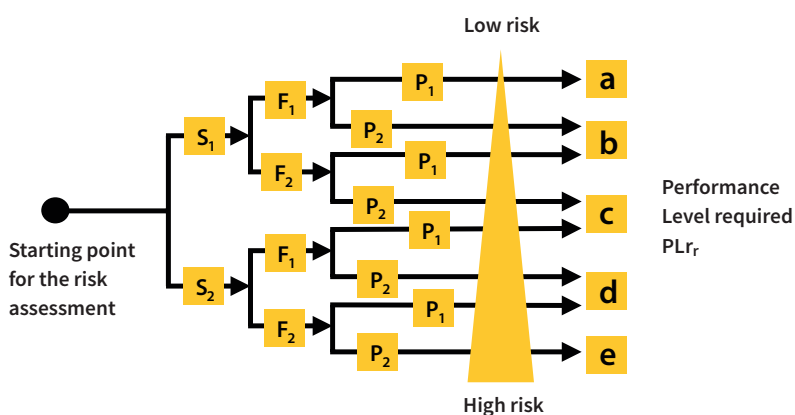

Effects and severity	S	Class K = F + W + P				
		3-4	5-7	8-10	11-13	14-15
Death, loss of an eye or an arm	4	SIL 2	SIL 2	SIL 2	SIL 3	SIL 3
Permanent, loss of fingers	3		AM	SIL 1	SIL 2	SIL 3
Reversible, medical treatment	2			AM	SIL 1	SIL 2
Reversible, First Aid	1				AM	SIL 1



SAMOS[®] PRO COMPACT

The safety control of the next generation

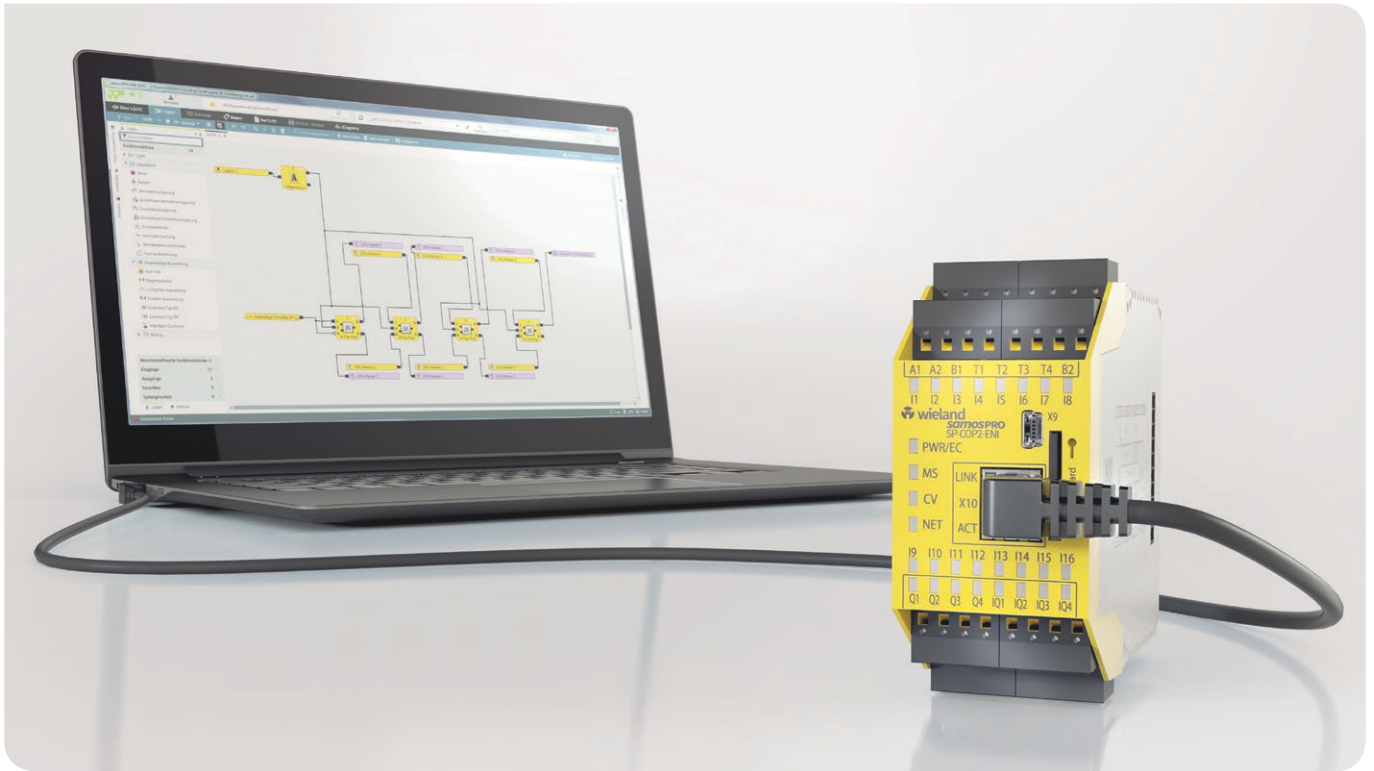

With the highest power in the smallest space, the safety control samos[®]PRO COMPACT sets new standards in the area of machine automation.

OVERVIEW OF BENEFITS

- 24 safe in- and outputs on 45 mm construction width for space and cost savings
- USB and Ethernet interfaces for remote maintenance always on board
- PROFINET IO, EtherNet/IP and Modbus TCP are integrated in the basic module
- 2 externe Gateways für EtherCAT, PROFIBUS DP and CANopen
- 4 A switching power at each individual pair of outputs to save small contactors and relays
- Ambient temperature -25°C to $+65^{\circ}\text{C}$
- Modular extendability to up to 172 safe in-/outputs, 12 I/O modules
- Optical display of all in- and outputs in system
- Screw or push-in terminals (included in scope of delivery)



SAMOS® PRO COMPACT PLUS

Enhanced functionality



samos®PRO

The samos®PRO COMPACT PLUS after module version E-01 offers more functionality like certified function blocks for safety automation of mechanical or hydraulic presses. Additionally it includes safe speed,

direction and position monitoring. Furthermore the hardware from construction stage E-01 for elevators and escalators according to EN 81-20 and EN 81-50.



APPLICATIONS IN MANY INDUSTRIES

samos®PRO COMPACT is appropriate for the usage in machines and plants, especially as a safety controller in presses, wood, metal and plastic working machines, packaging machines, assembly lines, wind turbines, elevators, escalators and process automation.

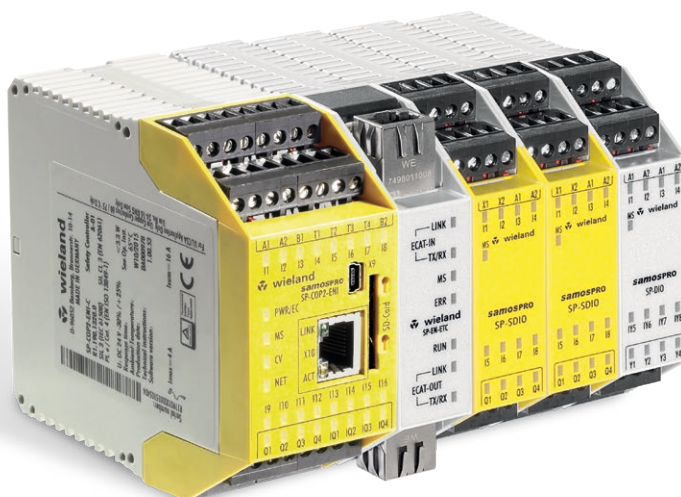



SAMOS® PLAN 6

the intuitive, flexible and license-free programming software

The new samos®PLAN 6 software for the samos®PRO COMPACT system now makes programming even easier.

samos®PLAN 6 assists PLC programmers, electrical design engineers and developers with the planning, validation, verification and documentation of the safety application.

FEATURES

- Modules are automatically selected by samos®PLAN 6
→ Programming possible without product knowledge or extensive training
- Gateways, functionalities such as "Press" or "Motion" can be configured via station capabilities
→ Users decide on properties and features instead of Hardware modules
- Sensors and actuators can be configured and programmed in one step
→ Engineering input and planning time significantly reduced



SAMOS® PLAN 6

Error-free thanks to simulation and online oscilloscope

samos®PRO

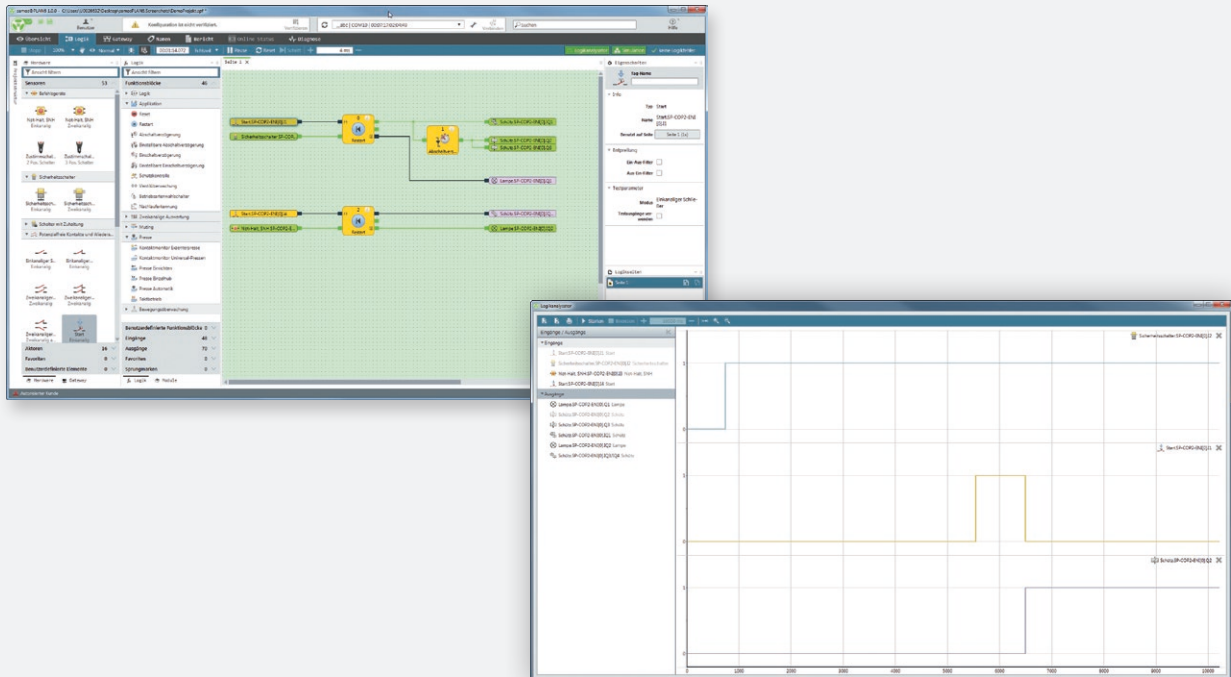

FEATURES

- Logic simulation in realtime or slowing to a factor of 20 possible
- Logging of simulated signals via logic analyzer
- Online logging of signals via online oscilloscope and export of the log data to Excel

ADVANTAGES

- Users can test the safety logic, incl. fast signal change and debouncing in advance
- Minimal errors during the planning phase and clean documentation
- Fast troubleshooting, validation, acceptance and documentation during commissioning

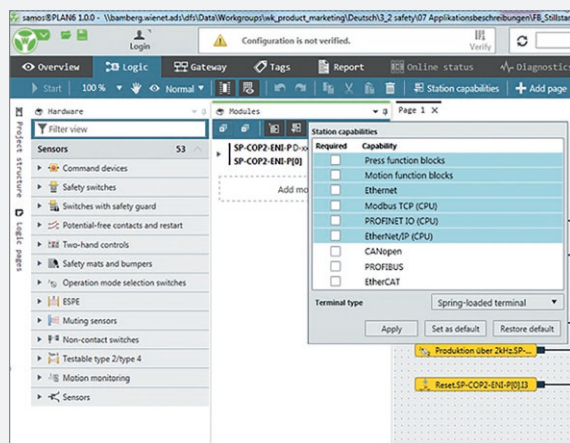

Intuitive thanks to automatic hardware configuration



SAMOS®PLAN 6

Cost-efficient thanks to integrated motion function

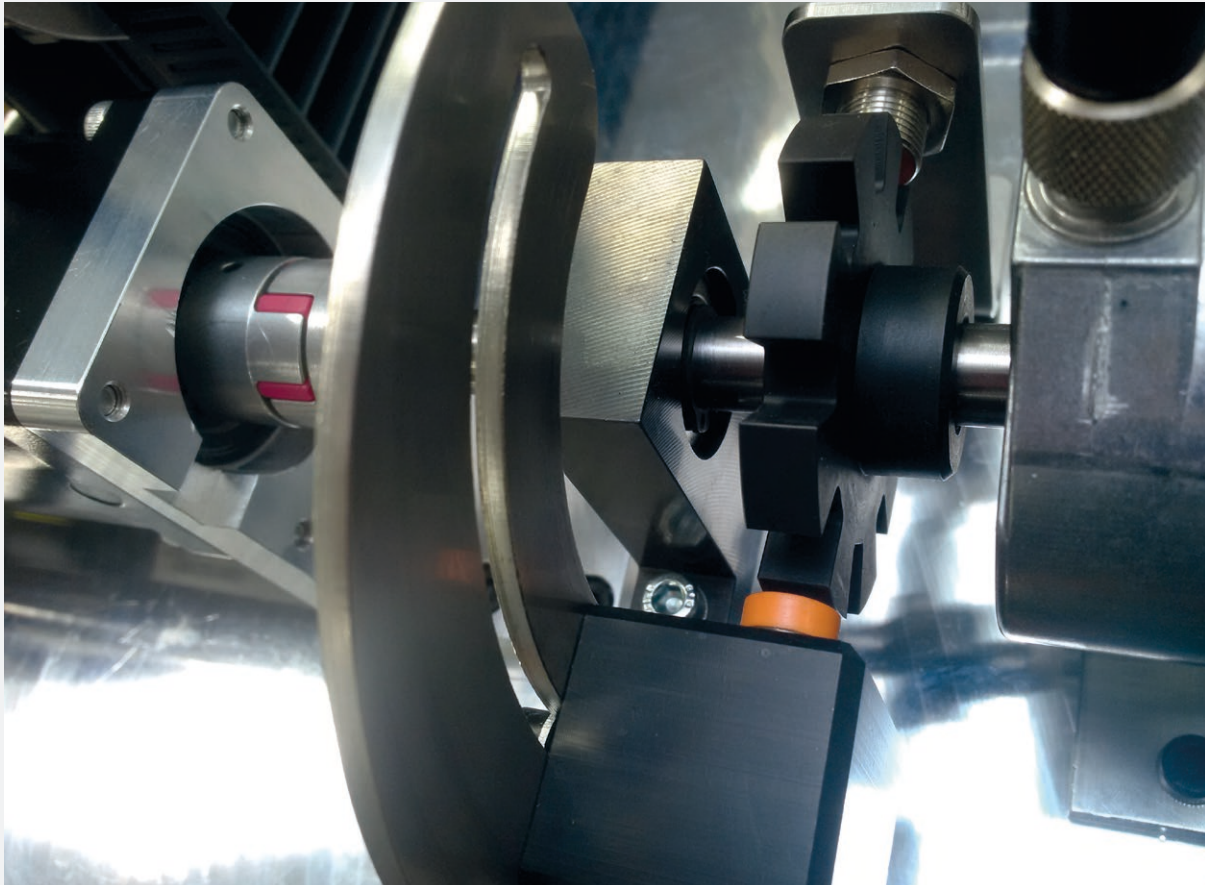

FEATURES

- Safe speed, direction and position monitoring integrated into the basic module
- All diagnostic information, including errors and warnings, are available in the software
- Multiple function blocks and limit values for standstill, SDI, SLS, SSR, SSM, SLP possible

ADVANTAGES

- Users save money, wiring and space in the control cabinet and require no additional motion module
- User-friendly diagnosis via LEDs, gateways or visualization on HMI panel
- Users require no additional rotational speed monitor thanks to software solution



MULTI-SCREEN FEATURE FOR FLEXIBILITY

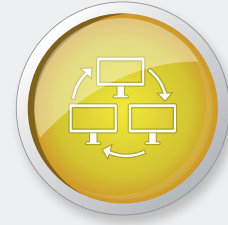

FEATURES

- Each operating window can be un-docked and docked
- Simulation, hardware and logic pages can be in separate windows
- Window arrangement can be saved under multiple profiles

ADVANTAGES

- Users are able to work flexibly with multiple screens
- Simple diagnosis, verification and troubleshooting on large-scale projects
- Each user can optimize their own workspace

RELIABLE THANKS TO TÜV-CERTIFIED FUNCTION BLOCKS

FEATURES

- Over 45 TÜV certified and practical function blocks
- Special function blocks for presses to EN 692 and EN 693
- Compact functions for sequential, parallel and cross-muting
- Fast shut-off functionality

ADVANTAGES

- Swift acceptance by the inspection organizations and CE-label for the machine
- Finished solutions for press manufacturers and retrofit specialists
- Swift integration of light curtains and light grids for conveying lines and production halls
- Realtime reaction between sensor and drive on the same safety module

REMOTE DIAGNOSIS AND FORCING FUNCTION FOR EASY MAINTENANCE

FEATURES

- Forcing of inputs and variables in samos®PLAN 6 up to 480 minutes (8 hours)
- Simple connection of diagnostic outputs to lamps and gateways
- Local or remote access to log of all system messages

ADVANTAGES

- Convenient on-site commissioning, even if components are missing
- Flexible diagnosis and signaling to lamps, PLCs or HMIs
- Fast troubleshooting during downtimes

SP-COP1

COMPACT MODULE

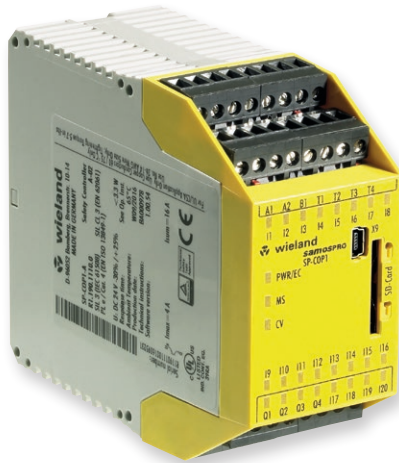

APPLICATIONS

- Machine building industry
- Presses
- Combustion plants
- Elevators and escalators
- Wind turbines
- SIL_{CL} 3 (EN 62061-1)
- PL e/Category 4 (EN ISO 13849-1)

FEATURES

- 20 inputs, 4 outputs on the basic module
- 116 safe inputs and 52 outputs with I/O extension \rightarrow modules
- Extension with 2 external gateway modules
- Mini USB programming interface
- SD slot for program memory (memory card SP-COP-CARD can be ordered separately)
- Terminals are included in the scope of delivery

OVERVIEW OF DEVICES | PART NUMBERS

Type	Rated voltage	Terminals	Remarks	Part no.	P.U.
SP-COP1-A	24 V DC	Screw terminals, pluggable		R1.190.1110.0	1
SP-COP1-P-A	24 V DC	Screw terminals, pluggable	PLUS: press, motion, analog	R1.190.1130.0	1
SP-COP1-C	24 V DC	Push-in terminals, pluggable		R1.190.1120.0	1
SP-COP1-P-C	24 V DC	Push-in terminals, pluggable	PLUS: press, motion, analog	R1.190.1140.0	1

TECHNICAL DATA

Function	Safety control
Function display	24 LED green (in-/outputs) 3 LED green/red/yellow (module status)
Supply circuit	
Operating voltage range	16.8 V DC to 30 V DC
Rated power	3.5 W
Electrical isolation supply circuit - control circuit	No
Safe input circuit I_n	
Quantity/type	20 / digital
Primary voltage range	15 V DC to 30 V DC
Nominal current	2 mA
Safe output circuit Q_n	
Quantity/type	4 / digital
Rated output voltage	24 V DC
Output current per output	4 A
Short-circuit protective device	Yes
Interfaces	
USB Mini interface	Yes
Ethernet interface	No
Industrial Ethernet protocol (basis module)	No
Industrial Ethernet protocol (with gateway module)	ETHERCAT, PROFIBUS DP, CANopen
Program memory	External
General data	
Protection class as per DIN EN 60529 (housing/terminals)	IP20
Air and creepage distances	EN 60664-1
Ambient temperature / storage temperature	-25 °C – +65 °C / -25 °C – +75 °C
Standards	EN 61508, EN 60204, EN 62061, EN ISO 13849-1, EN 81-20/50, EN 692, EN 693, EN/IEC 61511, EN 50156-1
Approvals	TÜV, cULus



SP-COP2

COMPACT MODULE WITH ETHERNET



APPLICATIONS

- Machine building industry
- Presses
- Combustion plants
- Elevators and escalators
- SIL_{CL} 3 (EN 62061-1)
- PL e/Kategorie 4 (EN ISO 13849-1)

MERKMALE

- 16 inputs, 4 outputs, 4 configurable I/O on basic module
- 112 safe inputs and 56 outputs with I/O extension module
- Extension with 2 external gateway modules
- Industrial Ethernet protocols on basic module
- Ethernet interface for programming
- Mini USB programming interface
- SD-Slot für Programmspeicher (Speicherkarte SP-COP-CARD separat bestellbar)
- Terminals are included in the scope of delivery

samos[®]PRO

OVERVIEW OF DEVICES | PART NUMBERS

Type	Terminals	Remarks	Part no.	P.U.
SP-COP2-EN-A	Screw terminals, pluggable	Ethernet	R1.190.1210.0	1
SP-COP2-EN-P-A	Screw terminals, pluggable	Ethernet, PLUS: press, motion, analog	R1.190.1230.0	1
SP-COP2-EN-C	Push-in terminals, pluggable	Ethernet	R1.190.1220.0	1
SP-COP2-EN-P-C	Push-in terminals, pluggable	Ethernet, PLUS: press, motion, analog	R1.190.1240.0	1
SP-COP2-ENI-A	Screw terminals, pluggable	Industrial Ethernet	R1.190.1310.0	1
SP-COP2-ENI-P-A	Screw terminals, pluggable	Industrial Ethernet, PLUS: press, motion, analog	R1.190.1330.0	1
SP-COP2-ENI-C	Push-in terminals, pluggable	Industrial Ethernet	R1.190.1320.0	1
SP-COP2-ENI-P-C	Push-in terminals, pluggable	Industrial Ethernet, PLUS: press, motion, analog	R1.190.1340.0	1

TECHNICAL DATA

Function	Safety control	
Function display	24 LED green (in-/outputs) 4 LED green/red/yellow (module status)	
Supply circuit		
Operating voltage range	16.8 V DC to 30 V DC	
Rated power	3.5 W	
Electrical isolation supply circuit - control circuit	No	
Safe input circuit I_n	SP-COP2-EN	SP-COP2-ENI
Quantity/type	20 (16) / digital	20 (16) / digital
Primary voltage range	15 V DC to 30 V DC	15 V DC to 30 V DC
Nominal current	2 mA	2 mA
Safe output circuit Q_n		
Quantity/type	4 (8) / digital	4 (8) / digital
Rated output voltage	24 V DC	24 V DC
Output current per output	4 A	4 A
Short-circuit protective device	Yes	Yes
Interfaces		
USB Mini interface	Yes	Yes
Ethernet interface	Yes	Yes
Industrial Ethernet protocol (basis module)	No	Modbus TCP, Profinet, Ethernet IP
Industrial Ethernet protocol (with gateway module)	ETHERCAT, PROFIBUS DP, CANopen	ETHERCAT, PROFIBUS DP, CANopen
Program memory	External	External
General data		
Protection class as per DIN EN 60529 (housing/terminals)	IP20	
Air and creepage distances	EN 60664-1	
Ambient temperature / storage temperature	-25 °C – +65 °C / -25 °C – +75 °C	
Standards	EN 61508, EN 60204, EN 62061, EN ISO 13849-1, EN 81-20/50, EN 692, EN 693, EN/IEC 61511, EN 50156-1	
Approvals	TÜV, cULus	

SP-SDIO

INPUT- / OUTPUT MODULE



APPLICATIONS

- Machine building industry
- Presses
- Combustion plants
- Elevator systems
- SIL_{CL} 3 (EN 62061-1)
- PL e / Category 4 (EN ISO 13849-1)

FEATURES

- 8 safe inputs
- 4 safe outputs (with/without output test-pulses)
- 2 outputs (e.g., test signals)

OVERVIEW OF DEVICES | PART NUMBERS

Type	Rated voltage	Terminals	Remarks	Part no.	P.U.
SP-SDIO84-P1-K-A	24 V DC	Screw terminals, pluggable	with/without output test-pulses	R1.190.0030.0	1
SP-SDIO84-P1-K-C	24 V DC	Push-in terminals, pluggable	with/without output test-pulses	R1.190.0040.0	1

TECHNICAL DATA

Function display	13 LEDs, green/red
Power supply circuit	
Operating voltage range	16.8 V DC to 30 V DC
Rated consumption	1.8 W
Electrical isolation power supply circuit - control circuit	no
Safe input circuit I1 – I8	
Quantity / type	8 / digital
Input voltage range	15 V DC to 30 V DC
Rated current	3 mA
Safe output circuits Q1 – Q4	
Quantity / type	4 / digital
Output voltage	24 V DC
Output current I _n per exit	4 A
Output circuits X1, X2	
Quantity / type	2 / digital
Output voltage	24 V DC
Output current I _n per exit	0.5 A
General data	
Protection degree according to DIN 60529 (housing / terminals)	IP40 / IP20
Creepage distances and clearances	EN 60664-1
Ambient temperature / storage temperature	-25°C – +65°C / -25°C – +75°C
Standards	EN 61508, EN 61511, EN 62061, EN ISO 13849-1, EN 50156-1
Approvals	TÜV, cULus

SP-SDI

INPUT MODULE

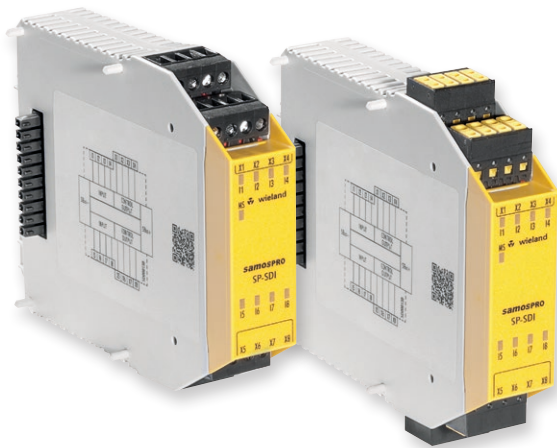

APPLICATIONS

- Machine building industry
- Presses
- Combustion plants
- Elevator systems
- SIL_{CL} 3 (EN 62061-1)
- PL e/Category 4 (EN ISO 13849-1)

FEATURES

- 8 safe inputs
- 8 outputs (e.g., test signals)



OVERVIEW OF DEVICES | PART NUMBERS

Type	Rated voltage	Terminals	Part no.	P.U.
SP-SDI8-P1-K-A	24 V DC	Screw terminals, pluggable	R1.190.0050.0	1
SP-SDI8-P1-K-C	24 V DC	Push-in terminals, pluggable	R1.190.0060.0	1

TECHNICAL DATA

Function display	13 LEDs, green/red
Power supply circuit	
Operating voltage range	16.8 V DC to 30 V DC
Rated consumption	1.8 W
Electrical isolation power supply circuit - control circuit	no
Safe input circuit I1 – I8	
Quantity / type	8 / digital
Input voltage range	15 V DC to 30 V DC
Rated current	3 mA
Output circuits X1, X2	
Quantity / type	2 / digital
Output voltage	24 V DC
Output current I _n per exit	0.5 A
General data	
Protection degree according to DIN 60529 (housing / terminals)	IP40 / IP20
Creepage distances and clearances	EN 60664-1
Ambient temperature / storage temperature	-25°C – +65°C / -25°C – +75°C
Standards	EN 61508, EN 61511, EN 62061, EN ISO 13849-1, EN 50156-1
Approvals	TÜV, cULus



NOTE:

Safe relay contacts are expanded using the series SNE contact expansion relay (from Page 68). Types **SNE 4024K** and **SNE 4012K** in particular are ideal for contact expansion.



SP-SA

ANALOG INPUT MODULE*)



APPLICATIONS

- Machine building industry
- Process industry
- Combustion plants
- up to SIL_{CL} 3 (EN 62061-1)
- up to PL e/Category 4 (EN ISO 13849-1)

FEATURES

- 4 safe analog inputs
- Galvanic isolation
- Limits monitoring
- Mathematical functions
- Scaling

OVERVIEW OF DEVICES | PART NUMBERS

Type	Rated voltage	Terminals	Remarks	Part no.	P.U.
SP-SAR4-A	DC 24 V	Screw terminals, pluggable	4 safe inputs RTD	R1.190.1610.0	1
SP-SAR4-C	DC 24 V	Push-in terminals, pluggable	4 safe inputs RTD	R1.190.1620.0	1
SP-SAC4-A	DC 24 V	Screw terminals, pluggable	4 safe inputs 0-20 mA	R1.190.1630.0	1
SP-SAC4-C	DC 24 V	Push-in terminals, pluggable	4 safe inputs 0-20 mA	R1.190.1640.0	1
SP-SACR22-A	DC 24 V	Screw terminals, pluggable	2 safe inputs RTD, 2 safe inputs 0-20 mA	R1.190.1650.0	1
SP-SACR22-C	DC 24 V	Push-in terminals, pluggable	2 safe inputs RTD, 2 safe inputs 0-20 mA	R1.190.1660.0	1

TECHNICAL DATA

Function display	6 LED green/red		
Power supply circuit			
Operating voltage range	16,8 V DC to 30 V DC		
Rated consumption	1,5 W		
Electrical isolation	yes (input circuit - supply circuit)		
Safe input circuit I_n	SP-SAR4	SP-SAC4	SP-SACR22
Quantity / type	4 / analog	4 / analog	4 / analog
Input type	4 x temperature-dependent resistor (RTD)	4 x power interface	2 x temperature-dependent resistor (RTD) 2 x power interface
Sensor type	PT100, PT200, PT500, PT1000, NI100, NI1000	0 - 20 mA, 4 - 20 mA	PT100, PT200, PT500, PT1000, NI100, NI1000 0 - 20 mA, 4 - 20 mA
Resolution	16 Bit	16 Bit	16 Bit
General data			
Protection degree according to DIN 60529	IP20		
Creepage distances and clearances	EN 60664-1		
Ambient temperature / storage temperature	-25 °C - +65 °C / -25 °C - +70 °C		
Standards	EN 61508, EN 61511, EN 62061, EN ISO 13849-1, EN 50156-1		
Approvals	TÜV, UL (pending)		

SP-DIO

STANDARD I/O-MODUL

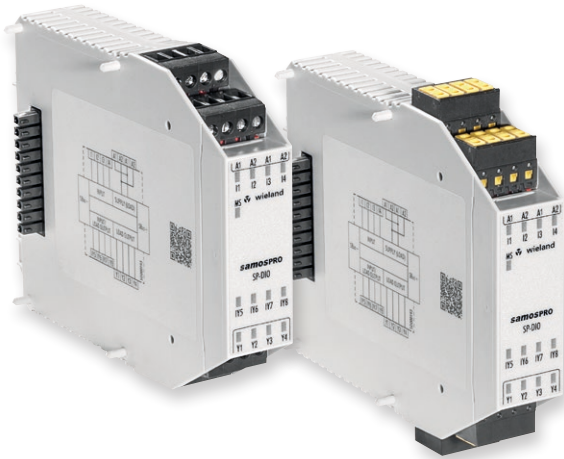

APPLICATIONS

- Machine building
- Presses
- Firing systems
- Elevator systems

MERKMALE

- 4 standard inputs
- 4 standard outputs
- 4 configurable standard in-/outputs

OVERVIEW OF DEVICES | PART NUMBERS

Type	Rated voltage	Terminals	Part no.	P.U.
SP-DIO84-K-A	24 V DC	Screw terminal, pluggable	R1.190.1050.0	1
SP-DIO84-K-C	24 V DC	Push-in terminal, pluggable	R1.190.1060.0	1

FUNCTION DISPLAY

Function display 13 LED, green/red

Function display

Operating voltage range U_B 16.8 V DC to 30 V DC

Rated power 0,5 W

Electrical isolation supply circuit - control circuit no

Standard input circuits I_n, IY_n

Quantity / type 4 (8) / digital

Input voltage range 15 V DC to 30 V DC

Nominal current 3 mA

Standard output circuits Q_n, IY_n

Quantity / type 4 (8) / digital

Output voltage 24 V DC

Output current I_n per output 0,5 A

Short-circuit protective device yes

General data

Protection class as per DIN EN 60529 (housing/terminals) IP40 / IP20

Air and creepage distances EN 60664-1

Ambient temperature / storage temperature -25°C - +65°C / -40°C - +70°C

Standards EN 60204, EN 50156-1

Approvals cULus

GATEWAY

With the samos®PRO gateways, system information can be transferred between the samos®PRO safe control and an industrial control, a visualization system or a PC.



APPLICATION EXAMPLES:

- Direct HMI connection
- Remote diagnosis and programming
- Read and write 50 byte
- Input and output states
- Configuration data
- Process data from the PLC
- Fault data (e.g. fault data of the connected sensor technology)



SP-CANOPEN

FEATURES

- Fieldbus protocol CANopen
- Bidirectional communication with PLC
- Transfer rate up to 1 MBit/s
- Transfer of 50 bytes of data
- Simple configuration with samos®PLAN 6
- Extended diagnosis and future compatibility (R1.190.0210.1)
- Note: for backward compatibility and existing projects please use R1.190.0210.0



SP-PROFIBUS-DP

FEATURES

- Fieldbus protocol PROFIBUS-DP
- Bidirectional communication with PLC
- Transfer rate 12 MBaud
- Transfer of 50 bytes of data
- Simple configuration with samos®PLAN 6
- Extended diagnosis and future compatibility (R1.190.0190.1)
- Note: for backward compatibility and existing projects please use R1.190.0210.0

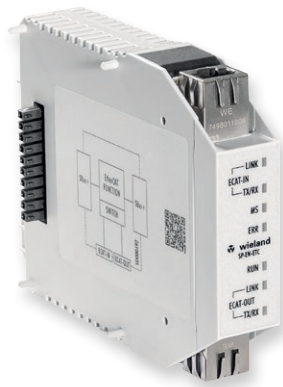

SP-EN-ETC

FEATURES

- EtherCAT industrial Ethernet protocol
- Bidirectional communication
- Transfer of 50 bytes of data
- Simple configuration with samos® PLAN 6

OVERVIEW OF DEVICES | PART NUMBERS

Type	Rated voltage	Remark	Part no.	P.U.
SP-CANopen	24 V DC	CANopen with extended diagnosis (with SP-COPx starting version D-xx)	R1.190.0210.1	1
SP-PROFIBUS-DP	24 V DC	PROFIBUS DP with extended diagnosis (with SP-COPx starting version D-xx)	R1.190.0190.1	1
SP-EN-ETC	24 V DC	ETHERCAT	R1.190.0160.0	1

STARTER SET & ACCESSORIES



SAMOS®PRO COMPACT STARTER SET

- A safe way to get started
- Contains all required components
- With programming tool samos®PLAN 6

SP-COP-STARTER-SET:

Set including SP-COP2-EN-A, SP-COP-CARD1, SP-PLAN6, SP-CABLE-USB1, SP-CABLE-ETH1



SP-COP-CARD1



SP-CABLE-USB1

SP-CABLE-ETH1

SAMOS®PRO ACCESSORIES

Contents of the starter set

- SP-COP-CARD1: Memory-card for SP-COP
- SP-CABLE-USB1: USB cable for SP-COP, 1.8 m
- SP-CABLE-ETH1: Ethernet cable for SP-COP, 2 m
- Programming software samos®PLAN 6

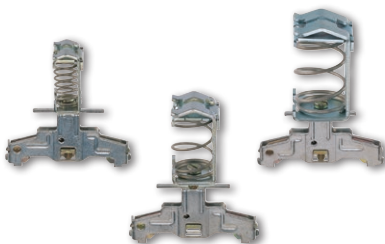

You can get the free programming tool samos®PLAN 6 at www.wieland-electric.com
Service / Software

STARTER SET & ACCESSORIES



HMI-ECO

FURTHER SAMOS®PRO ACCESSORIES

- For HMI-ECO touch panels and hmi plan visualization software, see Industrial Communication brochure (0801.0)

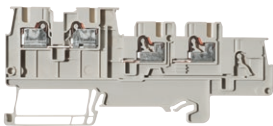

WTP 1,5 I/O -3

- Three-wire initiator/actuator terminal with push-in connection for mounting on MR 35

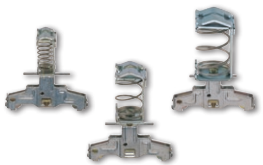

SHIELDED CABLE TERMINALS
FASIS WST .../T35

- For mounting on TS 35 mounting rail



SAFETY
SCHRAUBKL. SET

- Screw terminal set with 4 different codings for 5 devices

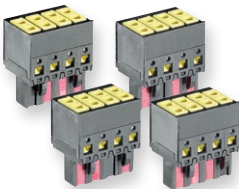

SAFETY
PUSH IN SET

- Push-in terminal set with 4 different codings for 5 devices

OVERVIEW OF DEVICES | PART NUMBERS

Type	Description	Part no.	P.U.
SP-COP-CARD1	Memory-card for SP-COP	R1.190.1000.0	1
SP-CABLE-USB1	USB cable for SP-COP, 1.8 m	R1.190.1010.0	1
SP-CABLE-ETH1	Ethernet cable for SP-COP, 2 m	R1.190.1020.0	1
SP-FILTER1	samos® PRO-Output-Filter, 680nF	R1.190.0260.0	1
SP-FILTER2	samos® PRO-Output-Filter, 2,2uF	R1.190.0270.0	1
SP-COP-STARTER-SET	Content: SP-COP2-EN-A, SP-COP-CARD1, SP-PLAN6, SP-CABLE-USB1, SP-CABLE-ETH1	R1.190.1100.0	1
HMI-LICENSE-SINGLE	Single-user license for HMIs, programming software for HMIs	ZW.000.0170.0	1
HMI-ECO-043	HMI Eco touch panel, 4.3" color, TFT, 480x272 pixels	83.050.0000.0	1
HMI-ECO-070	HMI Eco touch panel, 7" color widescreen, TFT, 800x480 pixels	83.050.0001.0	1
HMI-ECO-100	HMI Eco touch panel, 10" color, TFT, 1024x600 pixels	83.050.0002.0	1
SP-COVER	SD card slot cover for SP-COP modules	R1.190.1040.0	1
SAFETY SCHRAUBKL.SET	Screw terminal set with 4 different codings for 5 devices	99.208.9999.9	1
SAFETY PUSH IN SET	Push-in terminal set with 4 different codings for 5 devices	99.209.9999.9	1
WTP 1,5 I/O -3	fasis - multi-tier block with diodes	56.202.8055.0	100
APFN 2,5 E/35	End plate	07.312.7355.0	10
WST 8 / TS 35	For mounting on TS 35 mounting rail	Z2.803.6010.0	10
WST 13,5 / TS 35	For mounting on TS 35 mounting rail	Z2.803.6010.0	10
WST 20 / TS 35	For mounting on TS 35 mounting rail	Z2.803.6210.0	10

samos®PRO



SAMOS[®] – SAFETY MADE SIMPLE

samos[®] stands for SAFETY MOdular System. The safety system with just a multifunctional, permanently coded basic module is built on the modular kit principle and grows module by module along with the safety task.



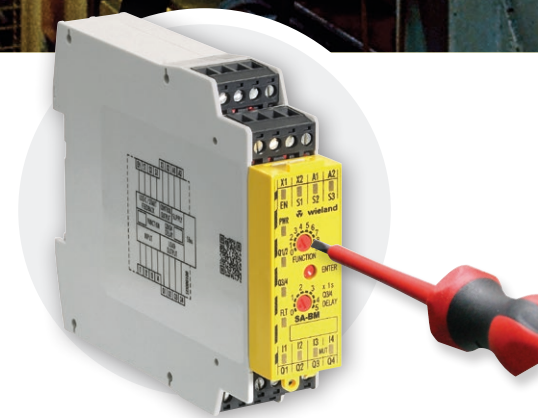
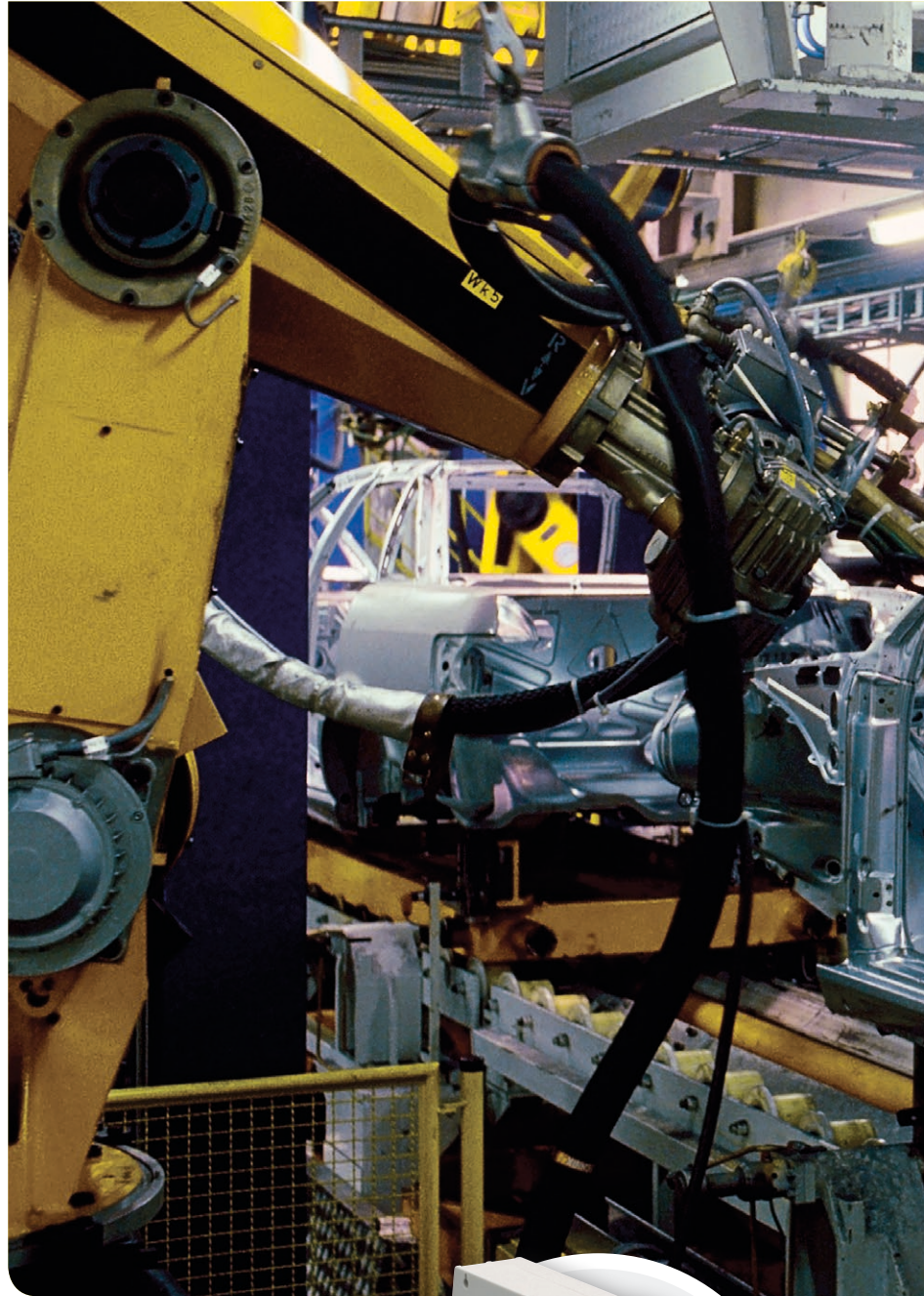







- samos[®] combines a wide variety of safety sensors which monitor a machine or system for technical safety either individually, in combination or all together.
- samos[®] replaces special devices with pre-defined, practice-oriented function blocks for monitoring emergency stop, position switches, two-hand buttons and light curtains, for example.
- samos[®] uses safe logical link functions for simple creation of dependent or independent safety zones.
- samos[®] offers comprehensive diagnosis by gateways via Profibus-DP, CANopen and DeviceNet or via Industrial Ethernet.



All safety functions are set with a screwdriver without programming software and can be read at the device.



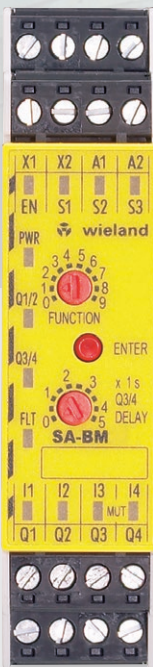

EXAMPLE: SINGLE FUNCTIONS

-  Emergency stop
-  Safety door
-  Controlled stopping
-  Monitoring BWS type 4
-  Monitoring BWS type 2 with testing
-  Testable PDF sensors
-  Safe position monitoring
-  Static valve monitoring
-  Two-hand applications to IIIA and IIIC
-  4-wire switching mats



Set release delay of output Q4 or Q3 and Q4

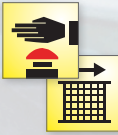
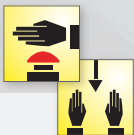

EXAMPLE: COMBINATION FUNCTIONS

-  TYPE 4/2
-  TYPE 4/2
-  TYPE 4/2
-  TYPE 4/2

EXAMPLE: DUAL FUNCTIONS

-  TYPE 4/2
-  TYPE 4/2

EXAMPLE: SPECIAL FUNCTIONS

-  Jog mode
-  Setup mode
-  MUTING and BYPASS



SAMOS® – MAXIMUM FLEXIBILITY

INTELLIGENTLY CONNECTED MODULES

The modules are connected to a standard DIN rail and pressed together. Connected on the left of the rail is the Master, the obligatory base module (with coding 1), input modules (coding matches the base module arranged to the left) and relay output modules. All modules in the samos overall system are permanently coded and are always permanently assigned to a similarly permanently coded basic module, which eliminates any confusion during service work, for instance.

The relay modules are integrated in the function via external wiring. If necessary such system group are made up of basic modules, input modules and relay output modules can be wired together. This allows the implementation of a wide variety of input/output functions with separate or combined effects.

FUNCTIONS WITH ADDED VALUE

The functions of the basic module and the input modules are set either individually or in combination on the front with 10-position rotary switches (e.g. emergency stop and protective door monitoring with controlled shutdown). Additional functions such as automatic reset, startup and re-startup blocking or retriggering of the off-delay are implemented with terminal configuration.

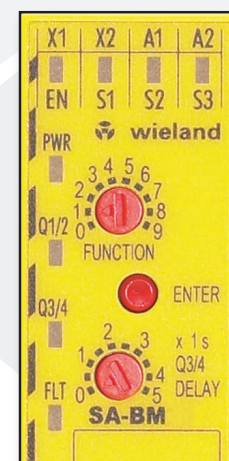

samos® MODULES

Clear handling – maximum flexibility

The clear and simple user interface helps to implement safe solutions.

1

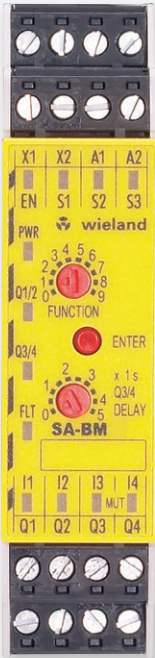

Basic master module

2

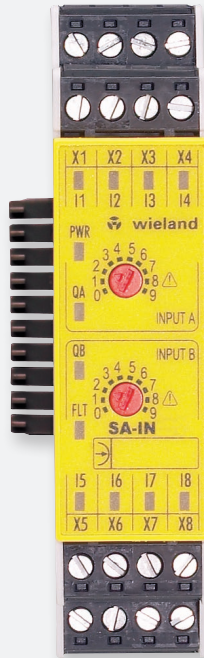

Input module

3

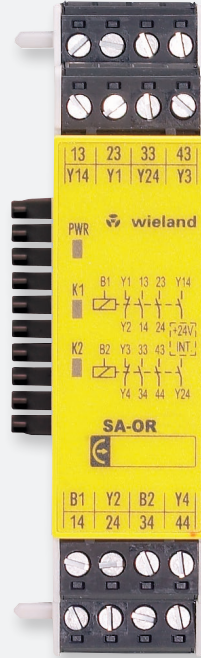

Output module relay

4



Gateway

samos®

MODULAR DESIGN

In its maximum configuration **samos®** consists of one basic master module and additional modules to expand function blocks, inputs and outputs.

- Up to **12** safe active modules (input modules)
- Up to **4** additional safe passive output module relays
- **1** additional gateway

1

Basic master module

Safety module with 9 function blocks, 8 safe inputs and 4 safe outputs (also suitable for stand-alone operation)

2

Input module

Expansion module with 10 function blocks and 8 safe inputs

3

Output module relay

Expansion modules with 2 or 4 safe, potential-free relay contacts

4

Gateway

Fieldbus or Ethernet gateways for easy diagnosis of the **samos®** system

SA-BM

BASIC MODULE



APPLICATIONS

- Machine building industry
- Combustion plants
- SIL_{CL} 3 (EN 62061-1)
- PL e / Category 4 (EN ISO 13849-1)

FEATURES

- 9 function blocks
- 4 inputs for safety sensors
- 4 safe semiconductor inputs
- Adjustable OFF- delay

OVERVIEW OF DEVICES | PART NUMBERS

Type	Rated voltage	Terminals	Coding	Part no.	P.U.
SA-BM-S1-4EKL-A, 5s	24 V DC	Screw terminals, pluggable	1	R1.180.0010.0	1
SA-BM-S1-4EKL-A, 50s	24 V DC	Screw terminals, pluggable	1	R1.180.0020.0	1
SA-BM-S1-4EKL-C, 5s	24 V DC	Push-in terminals, pluggable	1	R1.180.0360.0	1
SA-BM-S1-4EKL-C, 50s	24 V DC	Push-in terminals, pluggable	1	R1.180.0370.0	1

TECHNICAL DATA

Function display	12 LEDs, green/red
Power supply circuit	
Operating voltage range	19.2 V DC to 30 V DC
Rated consumption	1.8 W
Electrical isolation power supply circuit - control circuit	no
Safe input circuit I1 – I4	
Input voltage range	15 V DC to 30 V DC
Rated current	3 mA
Safe control circuits EN, S1 – S3	
Input voltage range	15 V DC to 30 V DC
Rated current	3 mA
Safe output circuits Q1 – Q4	
Output voltage	24 V DC
Output current I _n per exit	2 A
Output circuits X1, X2	
Output voltage	24 V DC
Output current I _n per exit	0.5 A
General technical data	
Protection degree according to DIN 60529 (housing / terminals)	IP40 / IP20
Creepage distances and clearances	EN 60664-1
Ambient temperature / storage temperature	-25°C – +55°C / -25°C – +75°C
Standards	EN 61508, EN 62061, EN ISO 13849-1, EN 50156-1
Approvals	TÜV, cULus

SA-IN

INPUT MODULE

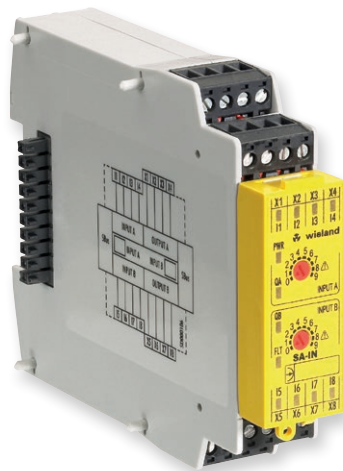

APPLICATIONS

- Machine building industry
- Combustion plants
- SIL_{CL} 3 (EN 62061-1)
- PL e/Category 4 (EN ISO 13849-1)

FEATURES

- 10 functional modules
- 2 x 4 inputs for sensors
- 2 x 4 test signal outputs

OVERVIEW OF DEVICES | PART NUMBERS

Type	Rated voltage	Terminals	Coding	Part no.	P.U.
SA-IN-S1-K-A	24 V DC	Screw terminals, pluggable	1	R1.180.0070.0	1
SA-IN-S1-K-C	24 V DC	Push-in terminals, pluggable	1	R1.180.0420.0	1

TECHNICAL DATA

Function display 12 LEDs, green/red

Power supply circuit

Operating voltage range 19.2 V DC to 30 V DC

Rated consumption 1.2 W

Electrical isolation power supply circuit - control circuit no

Safe input circuit I1 – I8

Input voltage range 15 V DC to 30 V DC

Rated current 3 mA

Output circuits X1, X8

Output voltage 24 V DC

Output current I_n per exit 0.5 A

General technical data

Protection degree according to DIN 60529 (housing / terminals) IP40 / IP20

Creepage distances and clearances EN 60664-1

Ambient temperature / storage temperature -25°C – +55°C / -25°C – +75°C

Standards EN 61508, EN 62061, EN ISO 13849-1, EN 50156-1

Approvals TÜV, cULus



SA-OR

OUTPUT MODULE



APPLICATIONS

- Machine building industry
- Combustion plants
- SIL_{CL} 3 (EN 62061-1)
- PL e / Category 4 (EN ISO 13849-1)

FEATURES

- Output module **SA-OR-S1**
 - 2 x 2 safe enabling with switching up to 230 V AC / 6 A
 - 2 x outputs 24 V DC / 50 mA
 - 2 x 1 feedback circuit (NC contact)
- Output module **SA-OR-S2**
 - 1 x 2 safe enabling with switching up to 230 V AC / 6 A
 - 1 x 1 potential-carrying safe output 24 V DC / 50 mA for signaling or safe logical operation
 - 1 x 1 feedback circuit (NC contact)

OVERVIEW OF DEVICES | PART NUMBERS

Type	Rated voltage	Terminals	Part no.	P.U.
SA-OR-S1-4RK-A	24 V DC	Screw terminals, pluggable	R1.180.0080.0	1
SA-OR-S2-2RK-A	24 V DC	Screw terminals, pluggable	R1.180.0320.0	1
SA-OR-S1-4RK-C	24 V DC	Push-in terminals, pluggable	R1.180.0430.0	1
SA-OR-S2-2RK-C	24 V DC	Push-in terminals, pluggable	R1.180.0440.0	1

TECHNICAL DATA

Function display	3 or 2 LEDs, green
Input circuit B1, B2	
Input voltage range	18 V DC to 30 V DC
Electrical isolation power supply circuit – input circuit	no
Electrical isolation input circuit - output circuit	yes
Electrical isolation power supply circuit - output circuit	yes
Rated consumption	2.2 W to 1.1 W
Release delay	30 ms
Output circuits (relays)	
Switching voltage	230 V AC
Output current I _n per exit	6 A
Output circuits (Y14, Y24)	
Switching voltage	30 V DC
Output current I _n per exit	75 mA
General technical data	
Protection degree according to DIN 60529 (housing / terminals)	IP40 / IP20
Creepage distances and clearances	EN 60664-1
Ambient temperature / storage temperature	-25°C – +55°C / -25°C – +75°C
Standards	EN 62061, EN ISO 13849-1, EN 50156-1
Approvals	TÜV, cULus

GATEWAY

With the samos® gateways, system information can be transferred from the configurable samos® safety system to an industrial control or a visualization system, for example



APPLICATION EXAMPLES:

- Input and Output states
- Configuration data
- Fault data (e.g., configuration faults, faults during operation)

SA-PROFIBUS-DP

FEATURES

- Fieldbus protocol PROFIBUS-DP
- Communication with PLC
- Transfer rate up to 12 MBaud
- 4 semi-conductor outputs on board

OVERVIEW OF DEVICES | PART NUMBERS

Type	Rated voltage	Terminals	Part no.	P.U.
SA-PROFIBUS-DP-A	24 V DC	Screw terminals, pluggable	R1.180.0090.0	1



SAFE RELAY – UNIVERSAL SAFETY RELAYS

The safeRELAY safety relays offer customized solutions for the safety of man and machine.

These devices combine excellent technical performance with efficient use in everyday industrial applications. Compact design, flexible use and flexible connection methods are the decisive advantages of these devices.

Depending on the application and the selected device, the safety relays can be used up to PL e/Category 4 (EN ISO 13849-1) or SIL 3 (EN 62061).

VERSATILE APPLICATION OPTIONS

- Emergency stop monitoring
- Monitoring of protective doors and interlocks
- Light curtain monitoring
- Two-hand relay
- Monitoring of valves and limit value switches
- Safe contact expansions

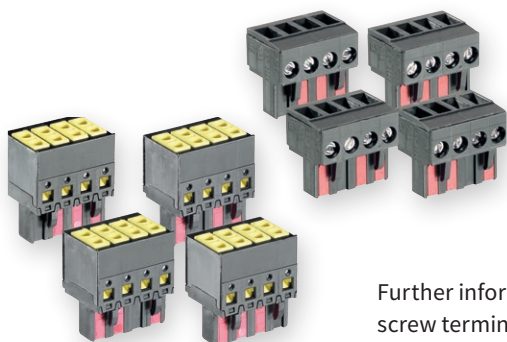

Further informations about the screw terminal set and the push-in terminal set see page 21.



safe RELAY

Safety relays

The simple and safe connection for every situation.



SNA, SNO, SNS, SNT, SNZ

Basic devices

The basic devices of the SNA, SNO, SNS, SNT and SNZ device families feature a safe internal logic component for the monitoring of the respective safety functions.



SNV

Basic devices with time function

The basic devices of the SNV device families feature a safe internal logic component for the monitoring of the respective safety functions.

In addition, these devices offer time-delayed, safe outputs and a corresponding time setting on the device.



SNE

Contact expansion relays

The contact expansion relays of the SNE device family feature a redundant internal structure and are used for contact multiplication, for example, basic devices.

OVERVIEW – BASIC DEVICES

Type	SNO 4083KM	SNO 4062K/KM	SNO 4063K/KM	SNA 4043K/KM	SNA 4044K/KM	SNA 4063K/KM	SNA 4064K/KM
Page	38	40	42	44	44	46	46
Application							
Input Circuits							
Start							
Contacts							
Characteristics							
Rated voltage DC (V)	24	24	12 24	24	24	24	24
Rated voltage AC (V)	115-230		24 115-120 230	24 115-120 230	24 115-120 230	24 115-120 230	24 115-120 230

¹⁾ PL e contact expansion

²⁾ 24 V devices only

³⁾ possible only in isolated cases and according to the risk assessment of the machine functions

	SNO 4003K	SNO 1012K	SNS 4074K/4084K	SVM 4001K	SNT 4M63K	SNZ 4052K	SNZ 1022K
	48	50	52	54	56	58	60
	24	24	24	24	24	24	24
	24 115-120 230	24			24 115-120 230	24 115-120 230	24 115-230

OVERVIEW – BASIC DEVICES WITH TIME FUNCTION

Type	SNV 4063KL	SNV 4063KP	SNV 4074SL	SNV 4076SL	SNV 4274SL	SNV 4074ST
Page	62	64	66	66	68	68
Application						
Input Circuits						
Start						
Contacts						
Characteristics						
Rated voltage DC (V)	24	24	24	24	24	24
Rated voltage AC (V)			115-230	115-230	115-230	115-230

¹⁾ applies to undelayed contacts; the following applies to delayed contacts: PL d / category 3 / SILCL 2

²⁾ depends on the category of the basic device or the safety analysis

CONTACT EXPANSION RELAYS



Type	SNE 1	SNE 4003K	SNE 4004K	SNE 4004KV	SNE 4012K	SNE 4024K	SNE 4028S
Page	70	72	74	74	76	76	78
Application							
Input Circuits							
Start							
Contacts							
Characteristics							
Rated voltage DC (V)	24	24	24	24	24	24	24
Rated voltage AC (V)			24				24 115-230

safe RELAY

For glossary, see cover page 140

SNO 4083KM

MONITORING OF EMERGENCY STOP, SAFETY GATES AND LIGHT BARRIERS



APPLICATIONS

- Protection of people and machinery
- Monitoring of emergency stop applications
- Monitoring of safety gates
- Monitoring of light barriers
- Up to PL e / Catégorie 4 (EN ISO 13849-1)
- Up to SIL_{CL} 3 (EN 62061)

FEATURES

- Stop Category 0 according to EN 60204-1
- Single-channel or two-channel control
- Two-channel control with NC/NC or NC/NO
- Manual or automatic start
- SafeStart
- Cross monitoring
- Synchronous time monitoring for two-channel control
- 3 enabling current path / 1 signalling current path

FUNCTION

After the supply voltage is applied to terminals A1/A2 and the safety inputs are closed, the enabling current paths (NO contacts) are closed and the signal current path (NC contact) is opened automatically or by pressing the reset button (manual monitored start). When the safety inputs are opened/ de-energized the enabling current paths (NO contacts) are opened immediately and the signal current path (NC contact) is closed.

- **Reduced installation work** – The SNO 4083KM requires fewer connection cables, irrespective of whether operation with or without cross monitoring is desired. This saves time and money when it comes to wiring.

- **Universal application** – The two-channel control of the device is carried out by either an NC/NC or an NC/NO combination of the safety sensor. In the case of two-channel control of the device, a synchronous time is automatically monitored between the two channels.
- **SafeStart function** – When the device is used with a manual start, the reset input is automatically monitored for a rising and falling signal edge. A manual reset signal is only accepted if the control inputs of the device are activated by the safe transducer (e.g. emergency stop button) during the entire activation procedure.
- **Monoflop function** – This function is integrated into the device and prevents device interlocking under all circumstances. This is a decisive advantage in applications where very short interruptions of the safety-related signals can occur, or in the case of transducers with bouncing contacts or safe optical sensors (BWS), for example.
- **Simple diagnosis** – The device features an intelligent display system that shows the user the different operating modes of the device in its different applications. This means, for example, that when the control inputs are closed and manual start has been selected, a reset signal is displayed, which has not yet been given. Fault states in the control (e.g. synchronous time exceeded or a short-circuit in two-channel control) are also signaled to the user via a blinking code.

CIRCUIT DIAGRAM

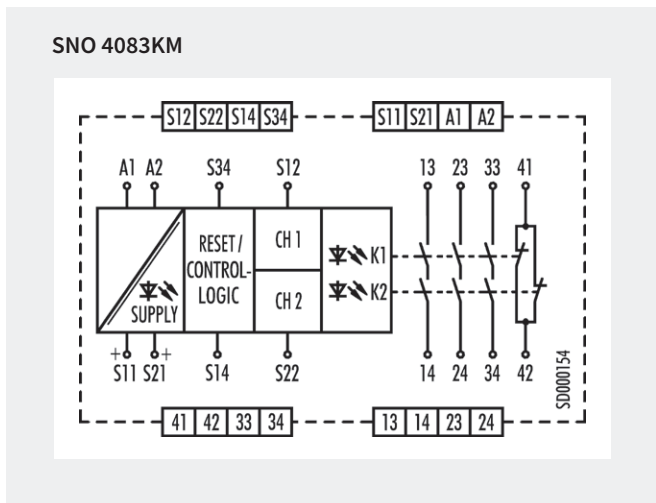



OVERVIEW OF DEVICES | PART NUMBERS

Type	Rated voltage	Synchr. Time	Terminals	Part no.	P.U.
SNO 4083KM-A	24 V DC	1.5 s	Screw terminals, pluggable	R1.188.3580.0	1
SNO 4083KM-A	115-230 V AC	1.5 s	Screw terminals, pluggable	R1.188.3590.0	1
SNO 4083KM-C	24 V DC	1.5 s	Push-in terminals, pluggable	R1.188.3600.0	1
SNO 4083KM-C	115-230 V AC	1.5 s	Push-in terminals, pluggable	R1.188.3610.0	1
SNO 4083KM-A	24 V DC	0.5 s	Screw terminals, pluggable	R1.188.3830.0	1
SNO 4083KM-A	115-230 V AC	0.5 s	Screw terminals, pluggable	R1.188.3840.0	1
SNO 4083KM-C	24 V DC	0.5 s	Push-in terminals, pluggable	R1.188.3850.0	1
SNO 4083KM-C	115-230 V AC	0.5 s	Push-in terminals, pluggable	R1.188.3860.0	1

TECHNICAL DATA

Function	Emergency stop relay	
Function display	3 LEDs, green	
Power supply circuit		
Rated voltage U_N	A1, A2	24 V DC / 115-230 V AC
Rated consumption	24 V DC	1.6 W
	115-230 V AC	1.8 W / 4.0 VA
Rated frequency	50 - 60 Hz	
Operating voltage range U_B	0.85 - 1.1 x U_N	
Electrical isolation supply circuit - control circuit	yes (at $U_N = 115-230$ V AC)	
Control circuit		
Rated output voltage	S11/S21	22.5 V DC
Input current / peak current	S12, S22	25 mA / 100 mA
	S14, S34	3 mA / 5 mA
Response time t_{A1} / t_{A2}	250 ms	
Minimum ON time t_M	60 ms	
Recovery time t_W	120 ms	
Release time t_R	< 35 ms	
Synchronous time t_S	0.5 s / 1.5 s	
Permissible test pulse time t_{pP}	< 0,8 ms	
Max. resistivity, per channel ¹⁾	24 V DC	$\leq (5 + (1.176 \times U_B / U_N - 1) \times 100) \Omega$
	115-230 V AC	$\leq 12 \Omega$
Output circuit		
Enabling paths	13/14, 23/24, 33/34	normally open contact
Signaling paths	41/42	normally closed contact
Contact assignment	forcebly guided	
Contact type	Ag-alloy, gold-plated	
Rated switching voltage	enabling / signaling path	230 V AC
Max. thermal current I_{th}	enabling / signaling path	6 A / 2 A
Max. total current I^2 of all current path	($T_u = 55^\circ\text{C}$) / ($T_u = 65^\circ\text{C}$)	25 A ² / 9 A ²
Application category (NO)	AC-15	$U_e 230\text{V}, I_e 5\text{A}$
	DC-13	$U_e 24\text{V}, I_e 5\text{A}$
Short-circuit protection (NO), lead fuse / circuit breaker	6 A class gG / melting integral < 100 A ² s	
Mechanical life	10 ⁷ switching cycles	
General data		
Creepage distances and clearances between the circuits	EN 60664-1	
Protection degree according to EN 60529 (housing / terminals)	IP40 / IP20	
Ambient temperature / storage temperature	-25 °C - +65 °C / -25 °C - +75 °C	
Wire ranges screw terminals,	fine-stranded / solid	1 x 0.2 mm ² - 2.5 mm ² / 2 x 0.2 mm ² - 1.0 mm ²
	fine-stranded with ferrules	1 x 0.25 mm ² - 2.5 mm ² / 2 x 0.25 mm ² - 1.0 mm ²
Permissible torque	0.5 - 0.6 Nm	
Wire ranges push-in terminals	1 x 0,25 mm ² - 1.5 mm ²	
Weight	24 V AC/DC device / AC device	0.2 kg
Standards	EN ISO 13849-1, EN 62061, EN 81-20/50, EN 50156-1, EN 61511	
Approvals	TÜV, cULus, CCC, GL	

¹⁾ If two-channel devices are installed as single channel, the value is halved.

SNO 4062K/KM

MONITORING OF EMERGENCY STOP, SAFETY GATES AND LIGHT BARRIERS



APPLICATIONS

- Protection of people and machinery
- Monitoring of emergency stop applications
- Monitoring of safety gates
- Monitoring of light barriers
- Up to PL e / Category 4 (EN ISO 13849-1)
- Up to SIL_{CL} 3 (EN 62061)

FEATURES

- Stop Category 0 according to EN 60204-1
- Reset button monitoring
- Manual or automatic start
Single-channel or two-channel control
- Cross monitoring
- 2 enabling current paths, 1 signal current path

FUNCTION

SNO 4062K

The device is a two-channel switching device for emergency stop applications with self-monitoring on each ON-OFF cycle. It complies with EN 60204-1 and is equipped with forcibly guided relays.

BASIC FUNCTION:

With supply voltage applied to terminals A1/A2 and the safety inputs closed, pressing the reset button closes the enabling current paths (manual start). When the safety inputs are opened/de-energized the enabling current paths will open.

- **Manual start** When the safety inputs are closed, a button is used to open reset input S34 (triggering with falling edge) or to close reset input S35 (triggering with rising edge).
- **Automatic start** Reset input S35 is connected to S33. The device starts with the rising edge of the signal on safety input S12.

SNO 4062KM

The function of this device corresponds to that of the SNO 4062K without synchrocheck. The device is suitable for connecting to light curtains for Type 4 (EN 61496-1) and connecting to short-circuit forming 4-wire safety mats, switching strips or switching edges (without monitoring resistance).

- **Safety mats** The device must be operated with two channels and cross monitoring. If there is resistance < 50 Ω / channel and a short circuit between the channels (S11/S12 and S21/S22) the enabling paths open and the SUPPLY LEDs flashes.
- **Light curtain for Type 4 (EN 61496-1)** The device will be operated with two channels and without cross monitoring, if the light curtain connected to the OSSD detects a shunt fault on its own.

For applications with tactile operating modes (rapid ON-OFF cycles, for example with manual supply) we recommend using SNO 4062KM.

CIRCUIT DIAGRAM

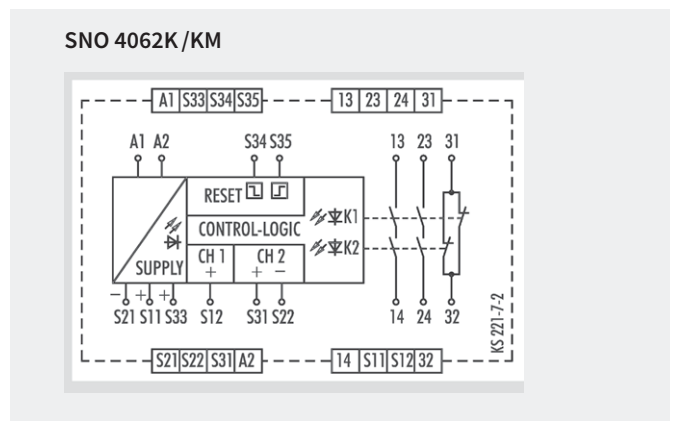



OVERVIEW OF DEVICES | PART NUMBERS

Type	Rated voltage	Terminals	Part no.	P.U.
SNO 4062K-A	24 V AC/DC	Screw terminals, pluggable	R1.188.0700.2	1
SNO 4062KM-A	24 V AC/DC	Screw terminals, pluggable	R1.188.0720.2	1
SNO 4062K-C	24 V AC/DC	Push-in terminals, pluggable	R1.188.2000.0	1

TECHNICAL DATA		
Function		Emergency stop relay
Function display		3 LEDs, green
Power supply circuit		
Rated voltage U_N	A1, A2	24 V AC/DC
Rated consumption	24 V DC (K / KM)	2.0 W / 2.1 W
Rated frequency		50 - 60 Hz
Operating voltage range U_B		0,85 - 1,1 x U_N
Electrical isolation supply circuit - control circuit		no
Control circuit		
Rated output voltage	S11, S33/S21	22 V DC
Input current / peak current	S12, S31/S22	40 mA / 100 mA
	S34, S35	5 mA / 50 mA
Response time t_{A1} / t_{A2}		40 ms / 500 ms (KM: 40 ms / 80 ms)
Minimum ON time t_M		50 ms
Recovery time t_W		150 ms
Release time t_R		< 25 ms
Synchronous time t_S		200 ms (CH1 → CH2)
Permissible test pulse time t_{TP}		< 1ms
Max. resistivity, per channel ¹⁾		$\leq (5 + (1.176 \times U_B / U_N - 1) \times 100) \Omega$
Output circuit		
Enabling paths	13/14, 23/24	normally open contact
Signaling paths	31/32	normally closed contact
Contact assignment		forcebly guided
Contact type		Ag-alloy, gold-plated
Rated switching voltage	enabling / signaling path	230 V AC
Max. thermal current I_{th}	enabling / signaling path	6 A / 3 A
Max. total current I^2 of all current path	($T_u = 55^\circ C$)	9 A ²
Application category (NO)	AC-15	$U_e 230 V, I_e 3 A$
	DC-13	$U_e 24 V, I_e 2.5 A$
Short-circuit protection (NO), lead fuse / circuit breaker		6 A class gG / melting integral < 100 A ² s
Mechanical life		10 ⁷ switching cycles
General data		
Creepage distances and clearances between the circuits		EN 60664-1
Protection degree according to EN 60529 (housing / terminals)		IP40 / IP20
Ambient temperature / storage temperature		-25 °C - +55 °C / -25 °C - + 75 °C
Wire ranges screw terminals,	fine-stranded / solid	1 x 0.2 mm ² - 2.5 mm ² / 2 x 0.2 mm ² - 1.0 mm ²
	fine-stranded with ferrules	1 x 0.25 mm ² - 2.5 mm ² / 2 x 0.25 mm ² - 1.0 mm ²
Permissible torque		0.5 - 0.6 Nm
Wire ranges push-in terminals		1 x 0.25 mm ² - 1.5 mm ²
Weight	24 V AC/DC device / AC device	0.21 kg
Standards		EN ISO 13849-1, EN 62061
Approvals		DGUV, cULus, CCC

¹⁾ If two-channel devices are installed as single channel, the value is halved.

SNO 4063K/KM

MONITORING OF EMERGENCY STOP, SAFETY GATES AND LIGHT BARRIERS



APPLICATIONS

- Protection of people and machinery
- Monitoring of emergency stop applications
- Monitoring of safety gates
- Monitoring of light barriers
- Up to PL e/Category 4 (EN ISO 13849-1)
- Up to SIL_{CL} 3 (EN 62061)

FEATURES

- Stop Category 0 according to EN 60204-1
- Manual or automatic start
- Cross monitoring
- Single-channel or two-channel control
- 3 enabling current paths

FUNCTION

SNO 4063K

The device is a two-channel switching device for emergency stop applications with self-monitoring on each ON-OFF cycle. It complies with EN 60204-1 and is equipped with forcibly guided relays.

After supply voltage has been applied to the A1/A2 terminals and the safety inputs have been closed, pressing the reset button closes the enabling current paths (manual start). When the safety inputs are opened/de-energized the enabling current paths will open.

- **Manual start** When the safety inputs are closed, a button is used to open reset input S34 (triggering with falling edge) or to close reset input S35 (triggering with rising edge).
- **Automatic start** Reset input S35 is connected to S33. The device starts with the rising edge of the signal on safety input S12.

SNO 4063KM

The function of this device corresponds to that of the SNO 4063K. The device is suitable for connecting to light curtains for Type 4 (EN 61496-1) and to short-circuit forming 4-wire safety mats, switching strips or switching edges (without monitoring resistance).

- **Safety mats** The device must be operated with two channels and cross monitoring. If there is resistance $< 50 \Omega$ / channel and a short circuit between the channels (S11/S12 and S21/S22) the enabling paths open and the SUPPLY LEDs flash.
- **Light curtain for Type 4 (EN 61496-1)** The device will be operated with two channels and without cross monitoring, if the light curtain connected to the OSSD detects a shunt fault on its own.

For applications with tactile operating modes (rapid ON-OFF cycles, for example at manual supply) we recommend the use of SNO 4063KM.

CIRCUIT DIAGRAM

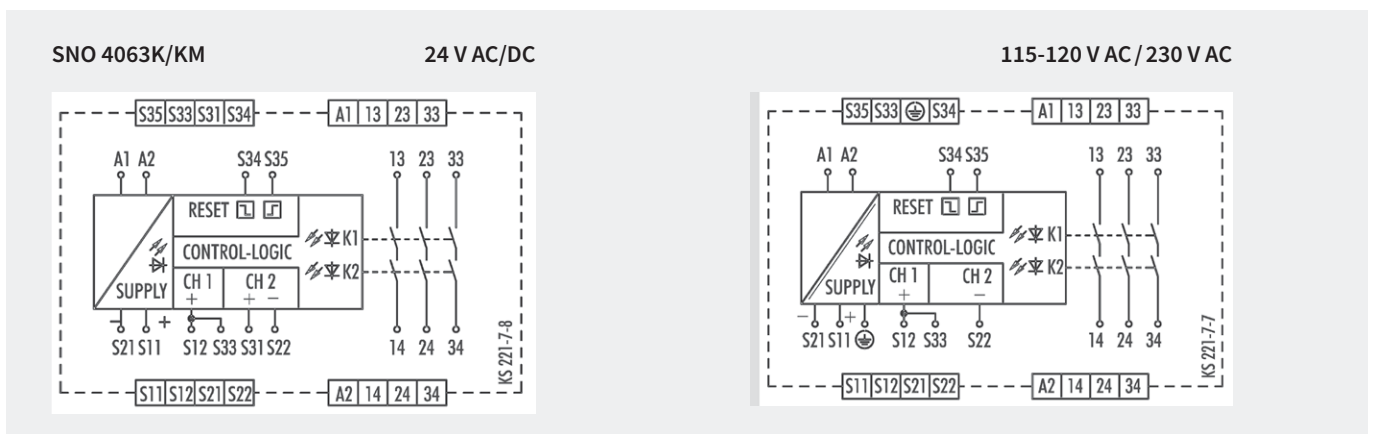



OVERVIEW OF DEVICES | PART NUMBERS

Type	Rated voltage	Terminals	Part no.	P.U.
SNO 4063K-A	12 V DC	Screw terminals, pluggable	R1.188.1120.0	1
	24 V AC/DC	Screw terminals, pluggable	R1.188.0990.0	1
	115 – 120 V AC	Screw terminals, pluggable	R1.188.1000.0	1
	230 V AC	Screw terminals, pluggable	R1.188.1010.0	1
SNO 4063K-C	24 V AC/DC	Push-in terminals, pluggable	R1.188.2450.0	1
SNO 4063KM-A	24 V AC/DC	Screw terminals, pluggable	R1.188.1280.0	1

TECHNICAL DATA

Function	Emergency stop relay	
Function display	3 LEDs, green	
Power supply circuit		
Rated voltage U_N	A1, A2	24 V AC/DC, 115-120 V AC, 230 V AC
Rated consumption	24 V DC (K / KM)	2.0 W / 2.1 W
	115-120 V AC, 230 V AC	2.4 W / 4.4 VA
Rated frequency	50 - 60 Hz	
Operating voltage range U_B	0.85 - 1.1 x U_N	
Electrical isolation supply circuit - control circuit	yes (at $U_N = 115-230$ V AC, 230 V AC)	
Control circuit		
Rated output voltage	S11/S21	22 V DC
Input current / peak current	S12/S33, S31/S22	40 mA / 100 mA
	S34, S35	5 mA / 50 mA
Response time t_{A1} / t_{A2}	40 ms / 600 ms	
Minimum ON time t_M	50 ms	
Recovery time t_W	100 ms	
Release time t_R	< 25 ms	
Synchronous time t_S	200 ms (CH1 → CH2)	
Permissible test pulse time t_{TP}	< 1 ms	
Max. resistivity, per channel ¹⁾	24 V AC/DC	$\leq (5 + (1.176 \times U_B / U_N - 1) \times 100) \Omega$
	115-120 V AC, 230 V AC	$\leq (5 + (1.176 \times U_B / U_N - 1) \times 100) \Omega$
Output circuit		
Enabling paths	13/14, 23/24, 33/34	normally open contact
Contact assignment	forcebly guided	
Contact type	Ag-alloy, gold-plated	
Rated switching voltage	enabling path	230 V AC
Max. thermal current I_{th}	enabling path	6 A
Max. total current I^2 of all current path	($T_u = 55^\circ\text{C}$)	9 A ²
Application category (NO)	AC-15	U_e 230 V, I_e 3 A
	DC-13	U_e 24 V, I_e 2.5 A
Short-circuit protection (NO), lead fuse / circuit breaker	6 A class gG / melting integral < 100 A ² s	
Mechanical life	10 ⁷ switching cycles	
General data		
Creepage distances and clearances between the circuits	EN 60664-1	
Protection degree according to EN 60529 (housing / terminals)	IP40 / IP20	
Ambient temperature / storage temperature	-25 °C - +55 °C / -25 °C - +75 °C	
Wire ranges screw terminals,	fine-stranded / solid	1 x 0.2 mm ² – 2.5 mm ² / 2 x 0.2 mm ² – 1.0 mm ²
	fine-stranded with ferrules	1 x 0.25 mm ² – 2.5 mm ² / 2 x 0.25 mm ² – 1.0 mm ²
Permissible torque	0.5 - 0.6 Nm	
Wire ranges push-in terminals	1 x 0.25 mm ² – 1.5 mm ²	
Weight	24 V AC/DC device / AC device	0-21 kg / 0-25 kg
Standards	EN ISO 13849-1, EN 62061	
Approvals	DGUV, cULus, CCC	

¹⁾ If two-channel devices are installed as single channel, the value is halved.

SNA 4043K/KM/KE, SNA 4044K/KM

MONITORING OF EMERGENCY STOP, SAFETY GATES AND LIGHT BARRIERS



APPLICATIONS

- Protection of people and machinery
- Monitoring of emergency stop applications
- Monitoring of safety gates
- Monitoring of light barriers
- Up to PL e / Category 4 (EN ISO 13849-1)
- Up to SIL_{CL} 3 (EN 62061)

FEATURES

- Stop Category 0 according to EN 60204-1
- Single-channel or two-channel control
- Automatic start
- Manual reset without monitoring
- Cross monitoring
- 3 to 4 enabling current paths

FUNCTION

Emergency stop and safety gate monitor The safety switching devices of our SNA product line are used to monitor safety sensors (emergency stop buttons, safety gate switches, etc.), feature a large number of safety switching contacts (3 NO contacts/1 NC contact or 4 NO contacts) with a total width of only 22.5 mm at a constant current of up to 8 A. They can be implemented in the extended temperature range up to 65° C.

- **Automatic start** – Reset input S34 is connected to safety input S11. To monitor external contact blocks (EDM), their NC contacts must be connected in series between S34 and S11.
- **Manual start without monitoring** – Reset input S34 is connected to safety input S11 via a RESET button. To monitor external contact blocks (EDM), their NC contacts must be connected to the RESET button in series.
- **Monitoring of light curtains** – The KM device types are especially suitable for the monitoring of very fast tactile switching operations, for example in safety light curtain applications. Very short switch-off procedures of a few milliseconds are detected reliably and lead to the switching off of the internal relays.

CIRCUIT DIAGRAM

SNA 4043K/KM

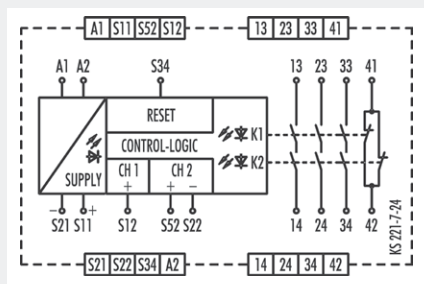

SNA 4043KE

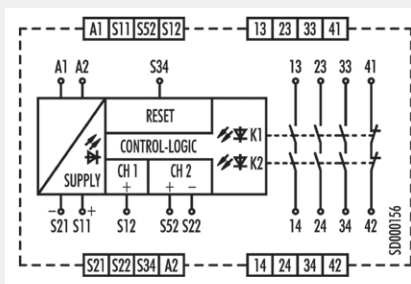

SNA 4044K/KM

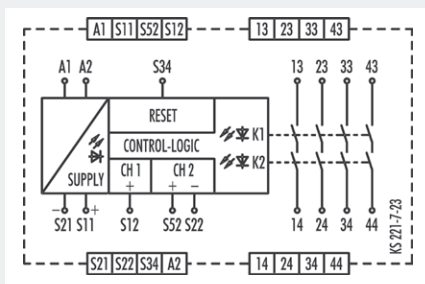



OVERVIEW OF DEVICES | PART NUMBERS

Type	Rated voltage	Terminals	Part no.	P.U.
SNA 4043K-A	24 V AC/DC	Screw terminals, pluggable	R1.188.1810.0	1
SNA 4043K-A	115-120 V AC	Screw terminals, pluggable	R1.188.1830.0	1
SNA 4043K-A	230 V AC	Screw terminals, pluggable	R1.188.1840.0	1
SNA 4043K-C	24 V AC/DC	Push-in terminals, pluggable	R1.188.1940.0	1
SNA 4043KM-A	24 V AC/DC	Screw terminals, pluggable	R1.188.3250.0	1
SNA 4043KM-C	24 V AC/DC	Push-in terminals, pluggable	R1.188.3400.0	1
SNA 4043KE-A	AC/DC 24 V	Screw terminals, pluggable	R1.188.3810.0	1
SNA 4043KE-C	AC/DC 24 V	Push-in terminals, pluggable	R1.188.3820.0	1
SNA 4044K-A	24 V AC/DC	Screw terminals, pluggable	R1.188.1860.0	1
SNA 4044K-A	115-120 V AC	Screw terminals, pluggable	R1.188.1880.0	1
SNA 4044K-A	230 V AC	Screw terminals, pluggable	R1.188.1890.0	1
SNA 4044K-C	24 V AC/DC	Push-in terminals, pluggable	R1.188.1960.0	1
SNA 4044KM-A	24 V AC/DC	Screw terminals, pluggable	R1.188.1480.0	1
SNA 4044KM-C	24 V AC/DC	Push-in terminals, pluggable	R1.188.3410.0	1

TECHNICAL DATA

Function	Emergency stop relay		
Function display	3 LEDs, green		
Power supply circuit			
Rated voltage U_N	A1, A2	24 V AC/DC / 42-48 V AC / 115-120 V AC / 230 V AC	
Rated consumption	24 V DC / 24 V AC	1.6 W / 2.9 VA	
	42-48 V AC / 115-120 V AC / 230 V AC	2.3 W / 2.6 VA	
Rated frequency	50 - 60 Hz		
Operating voltage range U_B	0.85 - 1.1 x U_N		
Electrical isolation supply circuit - control circuit	yes (at $U_N = 42-48$ V AC, 115-230 V AC, 230 V AC)		
Control circuit			
Rated output voltage	S11/S21	24 V DC	
Input current / peak current	S12, S52/S22 S34	25 mA / 100 mA 5 mA / 50 mA	
Response time t_{A1} / t_{A2}	350 ms / 350 ms		
Minimum ON time t_M	100 ms		
Recovery time t_W	750 ms		
Release time t_R	10 ms		
Synchronous time t_S	no		
Permissible test pulse time t_{TP}	< 1 ms		
Max. resistivity, per channel ¹⁾	24V AC/DC	$\leq (5 + (1.176 \times U_B / U_N - 1) \times 100) \Omega$	
	42-48V AC / 115-120 V AC, 230 V AC	$\leq (5 + (1.176 \times U_B / U_N - 1) \times 100) \Omega$	
Output circuit	SNA 4043K/KM	SNA 4044K/KM	
Enabling paths	13/14, 23/24, 33/34	13/14, 23/24, 33/34, 43/44	normally open contact
Signaling paths	41/42	---	normally closed contact
Contact assignment	forcebly guided		
Contact type	Ag-alloy, gold-plated		
Rated switching voltage	enabling / signaling path	230 V AC	
Max. thermal current I_{th}	enabling / signaling path	8 A / 5 A	
Max. total current I^2 of all current path	($T_u = 55^\circ C$) / ($T_u = 65^\circ C$)	25 A ² / 9 A ²	
Application category (NO)	AC-15 DC-13		U_e 230 V, I_e 3 A U_e 24 V, I_e 3 A
Short-circuit protection (NO), lead fuse / circuit breaker	6 A class gG / melting integral < 100 A ² s		
Mechanical life	10 ⁷ switching cycles		
General data			
Creepage distances and clearances between the circuits	EN 60664-1		
Protection degree according to EN 60529 (housing / terminals)	IP40 / IP20		
Ambient temperature / storage temperature	-25 °C - +65 °C / -25 °C - +75 °C		
Wire ranges screw terminals,	fine-stranded / solid	1 x 0.2 mm ² - 2.5 mm ² / 2 x 0.2 mm ² - 1.0 mm ²	
	fine-stranded with ferrules	1 x 0.25 mm ² - 2.5 mm ² / 2 x 0.25 mm ² - 1.0 mm ²	
Permissible torque	0.5 - 0.6 Nm		
Wire ranges push-in terminals	1 x 0.25 mm ² - 1.5 mm ²		
Weight	24 V AC/DC device / AC device	0.21 kg / 0.25 kg	
Standards	EN ISO 13849-1, EN 62061, EN 81-20/50, EN 50156-1, EN 61511		
Approvals	TÜV, cULus, CCC, GL		

¹⁾ If two-channel devices are installed as single channel, the value is halved.

SNA 4063K/KM, SNA 4064K/KM

MONITORING OF EMERGENCY STOP, SAFETY GATES AND LIGHT BARRIERS



APPLICATIONS

- Monitoring of emergency stop applications
- Monitoring of safety gates
- Monitoring of light barriers
- Up to PL e / Category 4 (EN ISO 13849-1)
- Up to SIL_{CL} 3 (EN 62061)

FEATURES

- Stop Category 0 according to EN 60204-1
- Single-channel or two-channel control
- Manual reset with monitoring
- Cross monitoring
- 3 to 4 enabling current paths

FUNCTION

After the supply voltage is applied to terminals A1/A2 and the safety inputs are closed, the enabling current paths (NO contacts) are closed and the signal current path (NC contact) is opened by pressing the reset button (manual start with monitoring). When the safety inputs are opened/de-energized, the enabling current paths (NO contacts) are opened immediately.

- **Manual start with monitoring** – Reset input S34 is connected to safety input S11 via a RESET button. To monitor external contact blocks (EDM), their NC contacts must be connected in series to the RESET button.
- **Monitoring of light curtains** – The **KM device types** are especially suitable for the monitoring of very fast tactile switching operations, for example in safety light curtain applications. Very short switch-off procedures of a few milliseconds are detected reliably and lead to the switching off of the internal relays.

CIRCUIT DIAGRAM

SNA 4063K/KM

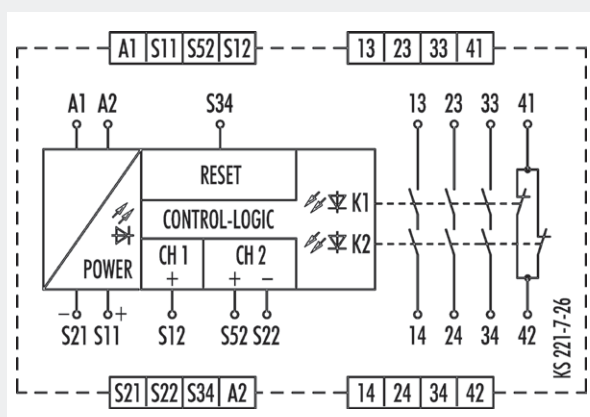

SNA 4064K/KM

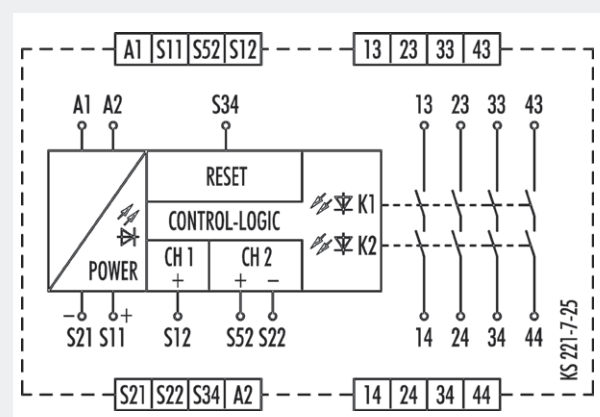



OVERVIEW OF DEVICES | PART NUMBERS

Type	Rated voltage	Terminals	Part no.	P.U.
SNA 4063K-A	24 V AC/DC	Screw terminals, pluggable	R1.188.1440.0	1
SNA 4063K-A	115-120 V AC	Screw terminals, pluggable	R1.188.1450.0	1
SNA 4063K-A	230 V AC	Screw terminals, pluggable	R1.188.1460.0	1
SNA 4063K-C	24 V AC/DC	Push-in terminals, pluggable	R1.188.1950.0	1
SNA 4063KM-A	24 V AC/DC	Screw terminals, pluggable	R1.188.3290.0	1
SNA 4063KM-C	24 V AC/DC	Push-in terminals, pluggable	R1.188.3420.0	1
SNA 4064K-A	24 V AC/DC	Screw terminals, pluggable	R1.188.1900.0	1
SNA 4064K-A	115-120 V AC	Screw terminals, pluggable	R1.188.1920.0	1
SNA 4064K-A	230 V AC	Screw terminals, pluggable	R1.188.1930.0	1
SNA 4064K-C	24 V AC/DC	Push-in terminals, pluggable	R1.188.1970.0	1
SNA 4064KM-A	24 V AC/DC	Screw terminals, pluggable	R1.188.3360.0	1
SNA 4064KM-C	24 V AC/DC	Push-in terminals, pluggable	R1.188.3430.0	1

TECHNICAL DATA

Function	Emergency stop relay		
Function display	3 LEDs, green		
Power supply circuit			
Rated voltage U_N	A1, A2	24 V AC/DC / 115-120 V AC / 230 V AC	
Rated consumption	24V DC / 24 V AC	1.6 W / 2.9 VA	
	42-48V AC / 115-120V AC / 230 V AC	2.3 W / 2.6 VA	
Rated frequency	50 - 60 Hz		
Operating voltage range U_B	0.85 - 1.1 x U_N		
Electrical isolation supply circuit - control circuit	yes (at $U_N = 115-230$ V AC, 230 V AC)		
Control circuit			
Rated output voltage	S11/S21	24 V DC	
Input current / peak current	S12, S52/S22 S34	25 mA / 100 mA 5 mA / 50 mA	
Response time t_{A1} / t_{A2}	100 ms / ---		
Minimum ON time t_M	100 ms		
Recovery time t_W	750 ms		
Release time t_R	10 ms		
Synchronous time t_S	no		
Permissible test pulse time t_{TP}	< 1 ms		
Max. resistivity, per channel ¹⁾		24V AC/DC	$\leq (5 + (1,176 \times U_B / U_N - 1) \times 100) \Omega$
		42-48V AC / 115-120 V AC, 230 V AC	$\leq (5 + (1,176 \times U_B / U_N - 1) \times 100) \Omega$
Output circuit			
	SNA 4063K/KM	SNA 4064K/KM	
Enabling paths	13/14, 23/24, 33/34	13/14, 23/24, 33/34, 43/44	normally open contact
Signaling paths	41/42	---	normally closed contact
Contact assignment	forcebly guided		
Contact type	Ag-alloy, gold-plated		
Rated switching voltage	enabling / signaling path		230 V AC
Max. thermal current I_{th}	enabling / signaling path		8 A / 5 A
Max. total current I^2 of all current path	(Tu = 55 °C) / (Tu = 65 °C)		25 A ² / 9 A ²
Application category (NO)	AC-15 DC-13		U_e 230 V, I_e 3 A U_e 24 V, I_e 3 A
Short-circuit protection (NO), lead fuse / circuit breaker	6 A class gG / melting integral < 100 A ² s		
Mechanical life	10 ⁷ switching cycles		
General data			
Creepage distances and clearances between the circuits	EN 60664-1		
Protection degree according to EN 60529 (housing / terminals)	IP40 / IP20		
Ambient temperature / storage temperature	-25 °C - +65 °C / -25 °C - +75 °C		
Wire ranges screw terminals,	fine-stranded / solid		1 x 0.2 mm ² - 2.5 mm ² / 2 x 0.2 mm ² - 1.0 mm ²
	fine-stranded with ferrules		1 x 0.25 mm ² - 2.5 mm ² / 2 x 0.25 mm ² - 1.0 mm ²
Permissible torque	0-5 - 0-6 Nm		
Wire ranges push-in terminals	1 x 0-25 mm ² bis 1-5 mm ²		
Weight	24 V AC/DC device / AC device		0-21 kg / 0-25 kg
Standards	EN ISO 13849-1, EN 62061, EN 81-20/50, EN 50156-1, EN 61511		
Approvals	TÜV, cULus, CCC, GL		

¹⁾ If two-channel devices are installed as single channel, the value is halved.

SNO 4003K

MONITORING OF EMERGENCY STOP AND SAFETY GATES



APPLICATIONS

- Protection of people and machinery
- Monitoring of emergency stop applications
- Monitoring of safety gates
- Up to PL d / Category 3 (EN ISO 13849-1)*
- Up to SIL_{CL} 2 (EN 62061)*

FEATURES

- Stop Category 0 according to EN 60204-1
- Single-channel or two-channel control
- Manual or automatic start
- 3 enabling current paths, 1 signal current path
- Feedback loop for monitoring external contactors

* PL e contact expansion

FUNCTION

The device is a single-channel switching device for emergency stop applications with self-monitoring on each ON-OFF cycle. It complies with EN 60204-1 and is equipped with forcibly guided relays.

The device has either two Y2 reset inputs (without reset monitoring) or two Y3 reset inputs (with reset monitoring). The K1 and K2 relays are actuated either automatically (bridge Y1 Y2) or after the reset button (on Y1 Y3) has been pressed. They become self-locking through their own contacts, if there is an electrical connection between terminal A1 and the supply voltage (emergency stop button, position switches).

After this switch-on phase the enabling current paths are closed and the signaling current path is open.

If the electrical connections between terminal A1 and the supply voltage are interrupted, the enabling current paths open and the signaling current path closes. The energized state (self-locking) of the two channels is indicated by a green LED K1, K2. The second green LED indicates that supply voltage has been applied. The set-up of an emergency stop facility after stop Category 0 (EN 60204-1) is possible.

CIRCUIT DIAGRAM

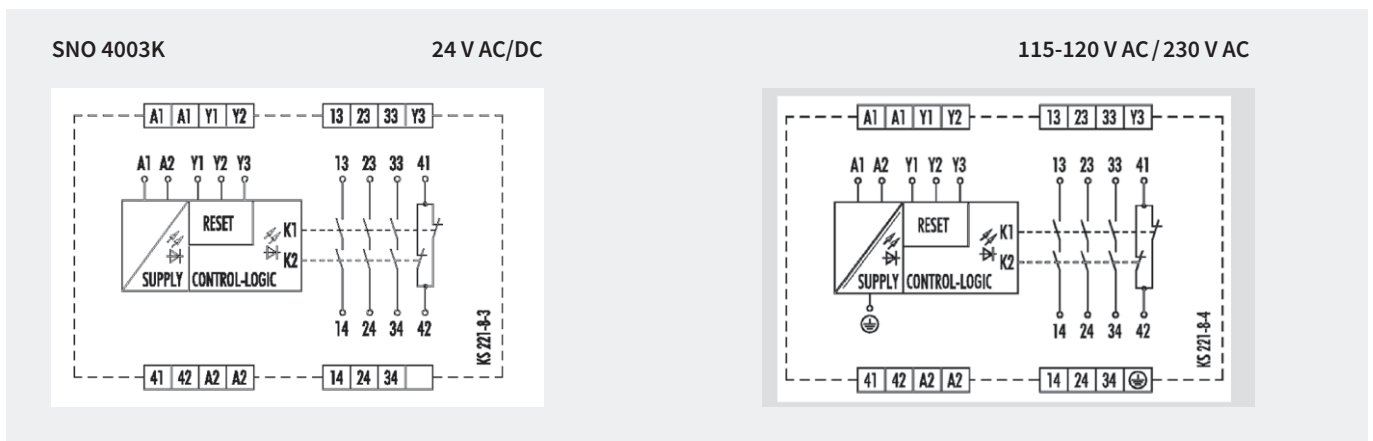



OVERVIEW OF DEVICES | PART NUMBERS

Type	Rated voltage	Terminals	Part no.	P.U.
SNO 4003K-A	24 V AC/DC	Screw terminals, pluggable	R1.188.0500.1	1
	115 – 120 V AC	Screw terminals, pluggable	R1.188.0900.1	1
	230 V AC	Screw terminals, pluggable	R1.188.0910.1	1
SNO 4003K-C	24 V AC/DC	Push-in terminals, pluggable	R1.188.1990.0	1
	115 – 120 V AC	Push-in terminals, pluggable	R1.188.4000.0	1
	230 V AC	Push-in terminals, pluggable	R1.188.4010.0	1

TECHNICAL DATA

Function	Emergency stop relay		
Function display	2 LEDs, green		
Power supply circuit			
Rated voltage U_N	A1, A2	24 V AC/DC / 115-120 V AC / 230 V AC	
Rated consumption	24 V DC	1.3 W	
	115-120 V AC, 230 V AC	2.2 W / 3.9 VA	
Rated frequency	50 - 60 Hz		
Operating voltage range U_B	0.85 - 1.1 x U_N		
Electrical isolation supply circuit - control circuit	yes (at $U_N = 115-120$ V AC, 230 V AC)		
Control circuit			
Rated output voltage	Y1	24 V DC	
Input current / peak current	Y2, Y3	90 mA / 1500 mA	
Response time t_{A1} / t_{A2}	60 ms		
Minimum ON time t_M (Manueller Start)	60 ms		
Recovery time t_W	200 ms		
Release time t_R	60 ms		
Max. resistivity	24V AC/DC	$\leq (2.5 + (1.176 \times U_B / U_N - 1) \times 50) \Omega$	
	115-120 V AC, 230 V AC	$\leq (7.5 + (1.176 \times U_B / U_N - 1) \times 150) \Omega$	
Output circuit			
Enabling paths	13/14, 23/24, 33/34		
Signaling paths	41/42	normally closed contact	
Contact assignment	forcebly guided		
Contact type	Ag-alloy, gold-plated		
Rated switching voltage	enabling / signaling path	230 V AC	
Max. thermal current I_{th}	enabling / signaling path	8 A / 5 A	
Max. total current I^2 of all current path	($T_u = 55^\circ\text{C}$)	9 A ²	
Application category (NO)	AC-15	U_e 230 V, I_e 5 A	
	DC-13	U_e 24 V, I_e 5 A	
Short-circuit protection (NO), lead fuse / circuit breaker	6 A class gG / melting integral $< 100 \text{ A}^2\text{s}$		
Mechanical life	10^7 switching cycles		
General data			
Creepage distances and clearances between the circuits	EN 60664-1		
Protection degree according to EN 60529 (housing / terminals)	IP40 / IP20		
Ambient temperature / storage temperature	$-25^\circ\text{C} - +55^\circ\text{C} / -25^\circ\text{C} - +75^\circ\text{C}$		
Wire ranges screw terminals,	fine-stranded / solid	$1 \times 0.2 \text{ mm}^2 - 2.5 \text{ mm}^2 / 2 \times 0.2 \text{ mm}^2 - 1.0 \text{ mm}^2$	
	fine-stranded with ferrules	$1 \times 0.25 \text{ mm}^2 - 2.5 \text{ mm}^2 / 2 \times 0.25 \text{ mm}^2 - 1.0 \text{ mm}^2$	
Permissible torque	0.5 - 0.6 Nm		
Wire ranges push-in terminals	$1 \times 0.25 \text{ mm}^2 - 1.5 \text{ mm}^2$		
Weight	24 V AC/DC device / AC device	0.20 kg / 0.25 kg	
Standards	EN ISO 13849-1, EN 62061		
Approvals	DGUV, cULus, CCC		

SNO 1012K

MONITORING OF EMERGENCY STOP AND SAFETY GATES



APPLICATIONS

- Protection of people and machinery
- Monitoring of emergency stop applications
- Monitoring of safety gates
- Up to PL d / Category 3 (EN ISO 13849-1)
- Up to SIL_{CL} 2 (EN 62061)

FEATURES

- Stop Category 0 according to EN 60204-1
- Single-channel or two-channel control
- Manual or automatic start
- 2 enabling current paths
- Check of external contactors (EDM)
- Compact design

FUNCTION

After the operating voltage (L+/L1) is applied via an unactuated emergency stop button or safety gate contact on A1 and A2, the device can be switched on via a Y1/Y2-connected reset button. When the device is on, the internal relays K1 and K2 are energized and the enabling current paths 13/14 and 23/24 are closed. When the emergency stop button or the safety gate contact is actuated, the current supply of the internal relays is interrupted and the enabling current paths are opened.

CIRCUIT DIAGRAM

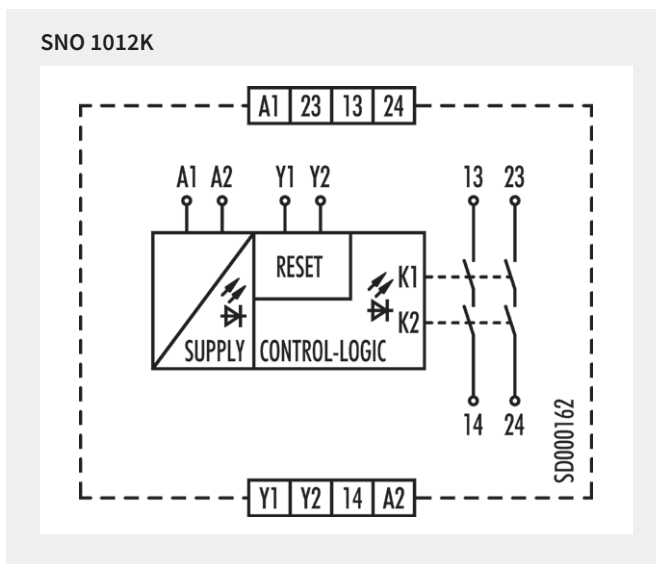



OVERVIEW OF DEVICES | PART NUMBERS

Type	Rated voltage	Terminals	Part no.	P.U.
SNO 1012K-A	24 V AC/DC	Screw terminals, pluggable	R1.188.3740.0	1
SNO 1012K-C	24 V AC/DC	Push-in terminals, pluggable	R1.188.3750.0	1

TECHNICAL DATA				
Function	Emergency stop relay			
Function display	2 LEDs, green			
Power supply circuit				
Rated voltage U_N	A1, A2	24 V AC/DC		
Rated consumption	24 V DC	1 W / 2 VA		
Rated frequency	50 - 60 Hz			
Operating voltage range U_B	0.85 - 1.1 x U_N			
Electrical isolation supply circuit - control circuit	no			
Control circuit				
Rated output voltage	Y1	24 V DC		
Input current / peak current	Y2	50 mA / 70 mA		
Response time t_{A1} / t_{A2}	< 20 ms / < 70 ms			
Minimum ON time t_M	30 ms			
Recovery time t_W	> 200 ms			
Release time t_R	< 70 ms			
Max. resistivity	$\leq (2.5 + (1.176 \times U_B / U_N - 1) \times 50) \Omega$			
Output circuit				
Enabling paths	13/14, 23/24	normally open contact		
Contact assignment	forceably guided			
Contact type	Ag-alloy, gold-plated			
Rated switching voltage	240 V AC / 50V DC			
Max. thermal current I_{th}	enabling path	6 A		
Max. total current I^2 of all current path	($T_u = 55^\circ C$)	72 A ² / 9 A ²		
Application category (NO)	AC-15	U_e 230 V, I_e 3 A		
	DC-13	U_e 24 V, I_e 3 A		
Short-circuit protection (NO), lead fuse / circuit breaker	6 A class gG / melting integral < 100 A ² s			
Mechanical life	10 x 10 ⁶ switching cycles			
General data				
Creepage distances and clearances between the circuits	EN 60664-1			
Protection degree according to EN 60529 (housing / terminals)	IP40 / IP20			
Ambient temperature / storage temperature	-25 °C - +55 °C / -25 °C - + 75 °C			
Wire ranges screw terminals,	fine-stranded / solid	1 x 0.2 mm ² – 2.5 mm ² / 2 x 0.2 mm ² – 1.0 mm ²		
	fine-stranded with ferrules	1 x 0.25 mm ² – 2.5 mm ² / 2 x 0.25 mm ² – 1.0 mm ²		
Permissible torque	0.5 - 0.6 Nm			
Wire ranges push-in terminals	2 x 0.25 mm ² – 1.5 mm ²			
Weight	0.12 kg			
Standards	EN ISO 13849-1, EN 62061			
Approvals	TÜV, cULus, CCC			

SNS 4074K / SNS 4084K

STANDSTILL MONITOR



APPLICATIONS

- Standstill monitoring
- Monitoring of electrical lockout devices
- Control of spring-actuated tumblers
- Monitoring of low rotational speeds in setup operation
- Up to PL e / Category 4 (EN ISO 13849-1)
- Up to SIL_{CL} 3 (EN 62061)

FEATURES

- Reliable monitoring of dynamic input signals
- Adjustable monitoring frequency 0.1 – 99 Hz
- 4 selectable operating mode groups
- Single-channel or two-channel control
- Manual or automatic start
- Cross monitoring
- 4 safe semi-conductor outputs

STANDSTILL MONITORING FUNCTION

The SNS 4084K standstill monitor provides for the safe monitoring of the frequency of a signal at inputs I1 to I4 of the device. If the frequency of the impulses is higher than the frequency set at the rotary switches (0.1 – 99 Hz), outputs Q1/Q2 will switch off. This monitoring function can be used to detect the standstill or a lower, safer rotational speed of a machine.

In applications of this sort, a spring-actuated or magnet-actuated tumbler of an electric interlocking device, for example, can be controlled from the output of the device.

The sensors for the detection of movement can, for example, be two inductive proximity switches or a rotary encoder connected to inputs I1 - I4. The frequency of the impulses to be monitored is set at the two rotary switches and splitter input T1, and is stored in the device on which the ENTER button is pressed while the voltage is applied to the device.

SNS 4074K

The device features a bypass input, which allows safety-oriented bypassing of the monitoring function, e.g. when a safe position has been reached. In this case, the signal must fulfill at least the safety category of the selected monitoring function.

SNS 4084K

The device features an input for the implementation of a start override, which allows the safe outputs to be switched off even during machine standstill. This means, for example, that a spring-actuated protective locking facility can be activated during machine start-up.

CIRCUIT DIAGRAM

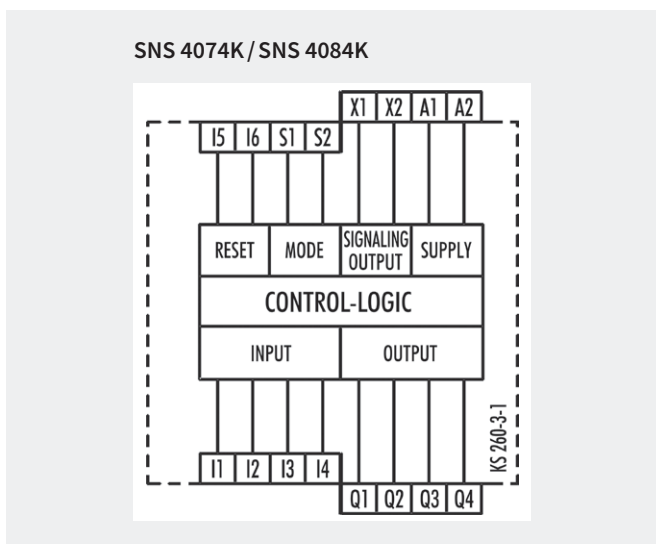

Terminals	Description
A1	+ 24 V
A2	GND
X1 / X2	Signal output, semi-conductor (plus switching)
S1	Configuration input for operating mode group
S2	Configuration input for operating mode group
I1	Sensor input
I2	Sensor / configuration input (depending on the operating mode group)
I3	Sensor / configuration input (depending on the operating mode group)
I4	Sensor / configuration input (depending on the operating mode group)
I5	Reset input
I6	Bypass input (SNS 4074K) / start override input (SNS 4084K)
Q1 / Q2	Safe Output, semi-conductor (plus switching)
Q3 / Q4	Safe Output, semi-conductor (plus switching), inverted

OVERVIEW OF DEVICES | PART NUMBERS

Type	Frequency range	Terminals	Part no.	P.U.
SNS 4074K-A	0.5 - 99 Hz	Screw terminals, pluggable	R1.188.3640.0	1
SNS 4074K-C	0.5 - 99 Hz	Push-in terminals, pluggable	R1.188.3650.0	1
SNS 4074K-A	0.1 - 9.9 Hz	Screw terminals, pluggable	R1.188.3620.0	1
SNS 4074K-C	0.1 - 9.9 Hz	Push-in terminals, pluggable	R1.188.3630.0	1
SNS 4084K-A	0.5 - 99 Hz	Screw terminals, pluggable	R1.188.3480.0	1
SNS 4084K-C	0.5 - 99 Hz	Push-in terminals, pluggable	R1.188.3490.0	1
SNS 4084K-A	0.1 - 9.9 Hz	Screw terminals, pluggable	R1.188.3660.0	1
SNS 4084K-C	0.1 - 9.9 Hz	Push-in terminals, pluggable	R1.188.3670.0	1

FUNCTION DIAGRAM

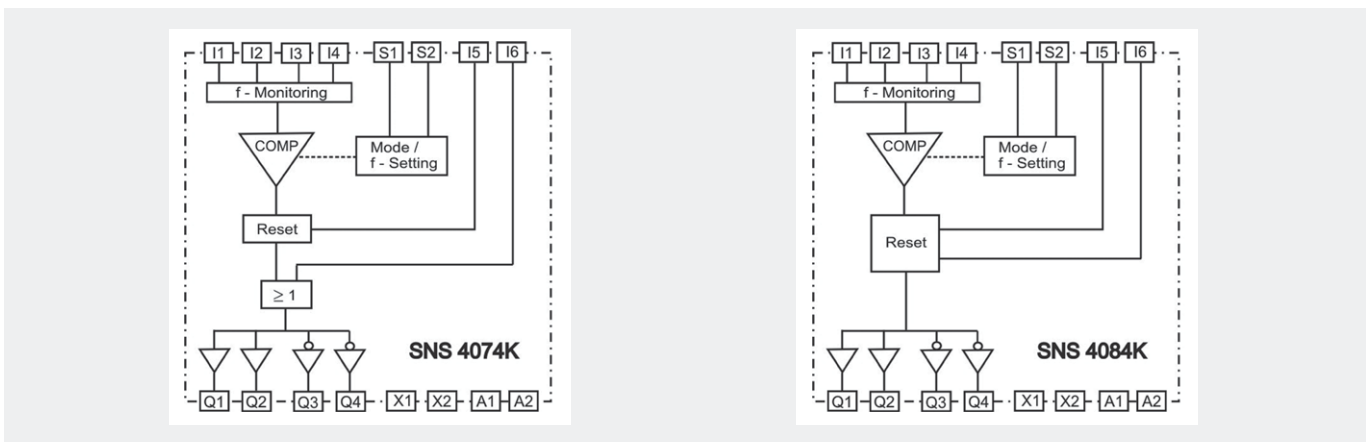

TECHNICAL DATA

Function		Standstill monitoring
Function display		12 LEDs, green/red
Function mode / adjustment		Frequency monitoring / 2 x-position switch
Adjustment range	f_{ST}	0,1 - 99 Hz / 0,5 - 99 Hz
Power supply circuit		
Rated voltage U_N	A1, A2	24 V DC
Rated consumption	24 V DC	1.8 W
Operating voltage range U_B		0.85 - 1.1 x U_N
Electrical isolation supply circuit - control circuit		no
Control circuit		
Rated output voltage		24 V DC
Input current / peak current	I1 - I6, S1, S2	3 mA / 3,8 mA
Minimum ON time t_M		100 ms (< 5 s)
Release time t_R		12 ms + 1.6 / f_{ST}
Max. cable length per input		100 m
Output circuit		
Enabling paths	Q1, Q2, Q3, Q4	Semi-conductor (plus switching), safety-related
Signaling paths	X1, X2	Semi-conductor (plus switching), not safety-related
Rated switching voltage	enabling path	30 V DC
Max. thermal current I_{th}	enabling path	2 A
Max. total current I^2 of all current path	($T_u = 55^\circ C$)	4 A
Mechanical life		Must be short-circuit proof
General data		
Creepage distances and clearances between the circuits		EN 60664-1
Protection degree according to EN 60529 (housing / terminals)		IP40 / IP20
Ambient temperature / storage temperature		-25 °C - +55 °C / -25 °C - + 75 °C
Wire ranges screw terminals,	fine-stranded / solid	1 x 0.2 mm ² - 2.5 mm ² / 2 x 0.2 mm ² - 1.0 mm ²
	fine-stranded with ferrules	1 x 0.25 mm ² - 2.5 mm ² / 2 x 0.25 mm ² - 1.0 mm ²
Permissible torque		0.5 - 0.6 Nm
Wire ranges push-in terminals		1 x 0.25 mm ² - 1.5 mm ²
Weight		0.16 kg
Standards		EN ISO 13849-1, EN 62061
Approvals		TÜV, cULus

SVM 4001K

STANDSTILL MONITOR



APPLICATIONS

- Standstill monitoring
- Monitoring of electrical lockout devices
- Control of spring-actuated tumblers
- Monitoring of low rotational speeds in setup operation
- Up to PL e / Category 4 (EN ISO 13849-1)
- Up to SIL_{CL} 3 (EN 62061)

FEATURES

- Sensorless monitoring of 1-phase and 3-phase motors
- Safe, configurable voltage monitoring
- Automatic operation

FUNCTION

The SVM 4001K device monitors machines, the 3-phase powered drive units of which have no movement detection sensors.

When the drives are set in motion or if faults are detected, the standstill monitor relay assumes the rest position.

APPLICATION

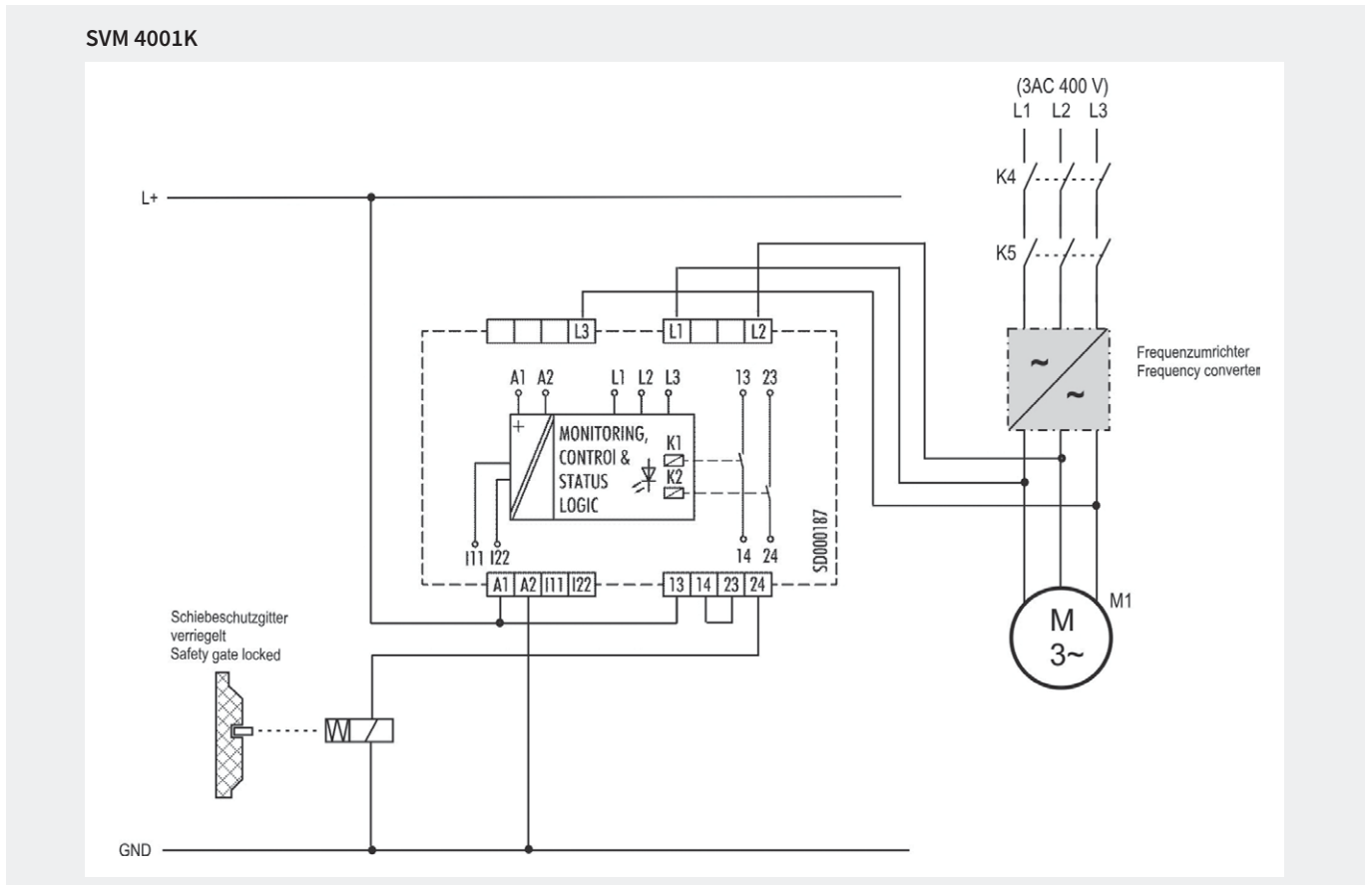

OVERVIEW OF DEVICES | PART NUMBERS

Type	Frequency range	Terminals	Part no.	P.U.
SVM 4001K-A	24 V DC	Screw terminals, pluggable	R1.188.4020.0	1
SVM 4001K-C	24 V DC	Push-in terminals, pluggable	R1.188.4030.0	1

CIRCUIT DIAGRAM

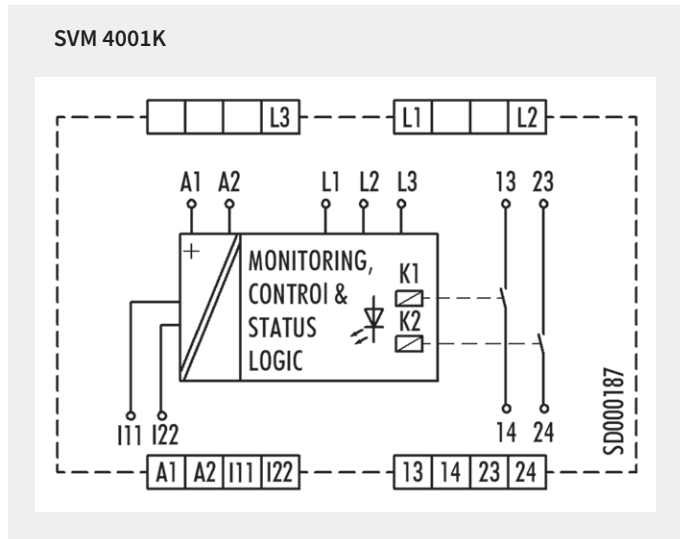

TECHNICAL DATA

Function		Standstill monitoring
Function display		4 LED, green/red
Function mode / adjustment		Voltage measurement
Adjustment range		50 - 500 mV
Power supply circuit		
Rated voltage U_N	A1, A2	24 V DC
Rated consumption	24 V DC	1.8 W
Operating voltage range U_B		0.85 - 1.1 x U_N
Control circuit		
Rated output voltage	U, V, W	690 V AC3
Response time t_A		20 ms
Release time t_R		20 ms
Output circuit		
Enabling paths	13/14, 23/24	normally open contact
Contact assignment		forceably guided
Contact type		Ag-alloy
Rated switching voltage		230 V AC
Max. thermal current I_{th}		8 A
Application category (NO)	AC-15	U_e 230 V, I_e 3 A
	DC-13	U_e 24 V, I_e 4 A
Short-circuit protection (NO), lead fuse / circuit breaker		5 A class gG
Mechanical life		20 x 10 ⁶ switching cycles
General data		
Creepage distances and clearances between the circuits		EN 60664-1
Protection degree according to EN 60529 (housing / terminals)		IP40 / IP20
Ambient temperature / storage temperature		-20 °C - +55 °C / -40 °C - +85 °C
Wire ranges screw terminals,	fine-stranded / solid	1 x 0.2 mm ² - 2.5 mm ² / 2 x 0.2 mm ² - 1.0 mm ²
	fine-stranded with ferrules	1 x 0.25 mm ² - 2.5 mm ² / 2 x 0.25 mm ² - 1.0 mm ²
Permissible torque		0.5 - 0.6 Nm
Wire ranges push-in terminals		1 x 0.25 mm ² - 1.5 mm ²
Weight		0.180 kg
Standards		EN ISO 13849-1, EN 62061
Approvals		TÜV, cULus

SNT 4M63K

MONITORING OF EMERGENCY STOP AND SAFETY GATES

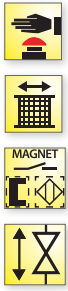

APPLICATIONS

- Protection of people and machinery
- Monitoring of emergency stop applications
- Monitoring of safety gates
- Up to PL e/Category 4 (EN ISO 13849-1)
- Up to SIL_{CL} 3 (EN 62061)

FEATURES

- Stop Category 0 according to EN 60204-1
- Manual or automatic start
- Cross monitoring
- 3 enabling current paths (NO contact, forcibly guided)
- Feedback loop for monitoring external contactors

FUNCTION

The device is a two-channel switching device with self-monitoring on each ON-OFF cycle. It complies with EN 60204-1 and is equipped with forcibly guided relays. It is intended for monitoring connected switching elements on separating safety devices and generating a safety-oriented signal (enable). Depending on the design, separating safety devices may include sliding safety gates, safety gates, housings, covers, sheetings, screens, etc.

BASIC FUNCTION

With supply voltage applied to terminals A1/A2 and the safety inputs closed, pressing the reset button closes the enabling current paths (manual start). When the safety inputs are opened the enabling paths will open.

- **Manual start** – When the safety inputs are closed, a button is used to close reset input S34 and open it again (triggering with falling edge) or to close reset input S35 (triggering with rising edge).
- **Automatic Start** – Reset input S35 is connected to S33/S14. The device starts with the rising edge of the signal on safety input S14.

CIRCUIT DIAGRAM

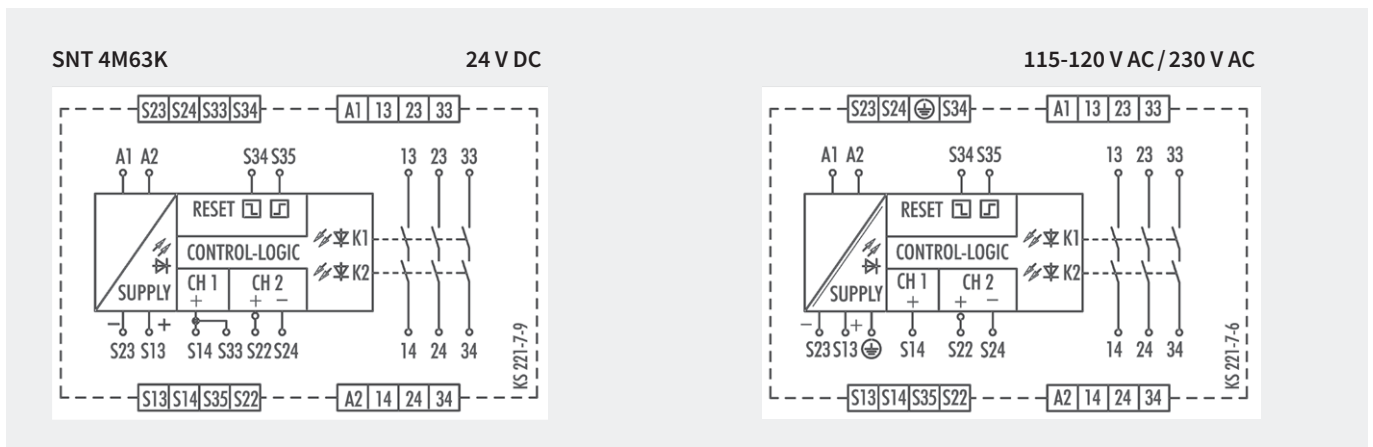



OVERVIEW OF DEVICES | PART NUMBERS

Type	Rated voltage	Terminals	Part no.	P.U.
SNT 4M63K-A	24 V AC/DC	Screw terminals, pluggable	R1.188.1050.0	1
	115 – 120 V AC	Screw terminals, pluggable	R1.188.1060.0	1
	230 V AC	Screw terminals, pluggable	R1.188.1070.0	1
SNT 4M63K-C	24 V AC/DC	Push-in terminals, pluggable	R1.188.2390.0	1

TECHNICAL DATA

Function	Emergency stop relay, valve position and safety gate monitoring		
Function display	3 LEDs, green		
Power supply circuit			
Rated voltage U_N	A1, A2	24 V AC/DC, 115-120 V AC, 230 V AC	
Rated consumption	24 V DC	2.0 W	
	115-120 V AC, 230 V AC	2,6 W / 3.2 VA	
Rated frequency	50 - 60 Hz		
Operating voltage range U_B	0.85 - 1.1 x U_N		
Electrical isolation supply circuit - control circuit	yes (at $U_N = 115-230$ V AC, 230 V AC)		
Control circuit			
Rated output voltage	S13/S23	22 V DC	
Input current / peak current	S14/S33, S22/S24	40 mA / 100 mA	
	S34, S35	5 mA / 50 mA	
Response time t_{A1} / t_{A2}	40 ms / 600 ms		
Minimum ON time t_M	80 ms		
Recovery time t_W	100 ms		
Release time t_R	15 ms		
Synchronous time t_S	200 ms (CH1 → CH2)		
Max. resistivity, per channel ¹⁾	24 V AC/DC	$\leq (5 + (1.176 \times U_B / U_N - 1) \times 100) \Omega$	
	115-120 V AC, 230 V AC	$\leq (5 + (1.176 \times U_B / U_N - 1) \times 100) \Omega$	
Output circuit			
Enabling paths	13/14, 23/24, 33/34	normally open contact	
Contact assignment	forcebly guided		
Contact type	Ag-alloy, gold-plated		
Rated switching voltage	enabling path	230 V AC	
Max. thermal current I_{th}	enabling path	6 A	
Max. total current I^2 of all current path	($T_u = 55^\circ\text{C}$)	9 A ²	
Application category (NO)	AC-15	U_e 230 V, I_e 3 A	
	DC-13	U_e 24 V, I_e 2.5 A	
Short-circuit protection (NO), lead fuse / circuit breaker	6 A class gG / melting integral < 100 A ² s		
Mechanical life	10 ⁷ switching cycles		
General data			
Creepage distances and clearances between the circuits	EN 60664-1		
Protection degree according to EN 60529 (housing / terminals)	IP40 / IP20		
Ambient temperature / storage temperature	-25 °C - +55 °C / -25 °C - + 75 °C		
Wire ranges screw terminals,	fine-stranded / solid	1 x 0.2 mm ² – 2.5 mm ² / 2 x 0.2 mm ² – 1.0 mm ²	
	fine-stranded with ferrules	1 x 0.25 mm ² – 2.5 mm ² / 2 x 0.25 mm ² – 1.0 mm ²	
Permissible torque	0.5 - 0.6 Nm		
Wire ranges push-in terminals	1 x 0.25 mm ² – 1-5 mm ²		
Weight	0-21 kg / 0-25 kg		
Standards	EN ISO 13849-1, EN 62061		
Approvals	DGUV, cULus, CCC		

¹⁾ If two-channel devices are installed as single channel, the value is halved.

SNZ 4052K

TWO-HAND RELAY TYPE IIIC



APPLICATIONS

- Protection of people and machinery
- Monitoring of two-hand applications
- Press
- According to EN 574 Type IIIC
- Up to PL e / Category 4 (EN ISO 13849-1)
- Up to SIL_{CL} 3 (EN 62061)

FEATURES

- Stop Category 0 according to EN 60204-1
- Two-channel actuation; 1 NO contact and 1 NC contact for each channel
- Cross monitoring
- Monitoring of synchronous activation
- 2 enabling current paths, 1 signaling current path

FUNCTION

The device complies with EN 574 Type III C safety requirements. The safety behavior of the device is designed for applications according to Category 4 (EN 954-1). The device is single-fault safe and self-monitoring. Synchronous activation of both actuators (two-hand momentary contact or safety gate contacts) is monitored. Each of the two actuators is connected to the device with an NO contact and an NC contact. The technical design of the input circuit provides cross connection and ground fault monitoring. The output function is designed with 2 NO contacts as an enabling current path and 1 NC contact as signaling current path (all forcibly guided).

With supply voltage applied to terminals A1/A2 and the feedback loop (terminals Y1/Y2) closed, the enabling current paths are closed by simultaneously activating the actuators (S1+S2).

Both actuators must be activated within 0.5 s for the output contacts to be enabled. If only one of the two actuators is released, the device is immediately de-energized. The enabling current paths open.

The device can be restarted only after both actuators have returned to their initial position (for example when the two-hand momentary contact switches have been released) and the feedback circuit is closed again. The feedback circuit should only be opened again after both actuators are activated. Otherwise the device will remain in the OFF position. The current status of the device is indicated by 3 LEDs: application of the supply voltage with LED SUPPLY, activation of both actuators with LED K1 and additionally with LED K2 in case of synchronous activation.

CIRCUIT DIAGRAM

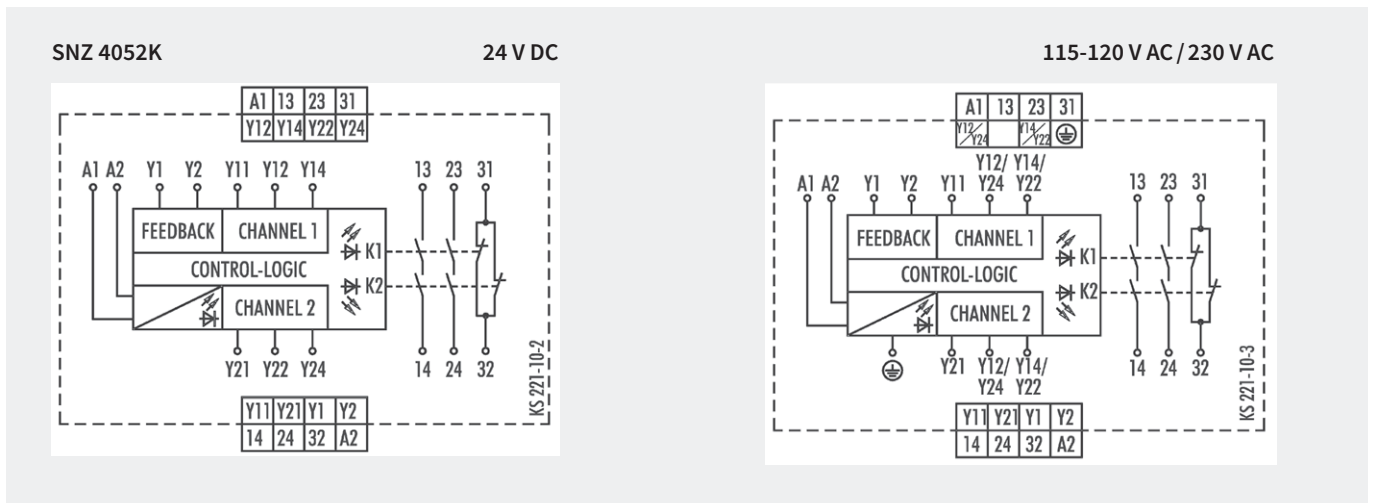



OVERVIEW OF DEVICES | PART NUMBERS

Type	Rated voltage	Terminals	Part no.	P.U.
SNZ 4052K-A	24 V AC/DC	Screw terminals, pluggable	R1.188.0530.1	1
	115 – 120 V AC	Screw terminals, pluggable	R1.188.0940.1	1
	230 V AC	Screw terminals, pluggable	R1.188.0950.1	1
SNZ 4052K-C	24 V AC/DC	Push-in terminals, pluggable	R1.188.2020.0	1

TECHNICAL DATA

Function	Two-hand control relay		
Function display	3 LEDs, green		
Power supply circuit			
Rated voltage U_N	A1, A2	24 V AC/DC, 115-120 V AC, 230 V AC	
Rated consumption	24 V DC	2.4 W	
	115-120 V AC, 230 V AC	2.2 W / 3.1 VA	
Rated frequency	50 - 60 Hz		
Operating voltage range U_B	0.85 - 1.1 x U_N		
Electrical isolation supply circuit - control circuit	yes (at $U_N = 115-230$ V AC, 230 V AC)		
Control circuit			
Rated output voltage	Y12/Y14, Y22/Y24, Y1	24 V DC	
Input current / peak current	Y11, Y21	60 mA / 1000 mA	
	Y2	< 100 mA	
Response time t_{A1} / t_{A2}	40 ms		
Recovery time t_W	250 ms		
Release time t_R	50 ms		
Synchronous time t_S	≤ 500 ms		
Max. resistivity, per channel	24 V AC/DC	$\leq (2.5 + (1.176 \times U_B / U_N - 1) \times 50) \Omega$	
	115-120 V AC, 230 V AC	$\leq (2.5 + (1.176 \times U_B / U_N - 1) \times 50) \Omega$	
Output circuit			
Enabling paths	13/14, 23/24	normally open contact	
Signaling paths	31/32	normally closed contact	
Contact assignment	forcebly guided		
Contact type	Ag-alloy, gold-plated		
Rated switching voltage	enabling / signaling path	230 V AC	
Max. thermal current I_{th}	enabling / signaling path	6 A / 2 A	
Max. total current I^2 of all current path	($T_u = 55$ °C)	9 A ²	
Application category (NO)	AC-15	$U_e 230$ V, $I_e 3$ A	
	DC-13	$U_e 24$ V, $I_e 2.5$ A	
Short-circuit protection (NO), lead fuse / circuit breaker	6 A class gG / melting integral / < 100 A ² s		
Mechanical life	10 ⁷ switching cycles		
General data			
Creepage distances and clearances between the circuits	EN 60664-1		
Protection degree according to EN 60529 (housing / terminals)	IP40 / IP20		
Ambient temperature / storage temperature	-25 °C - +55 °C / -25 °C - + 75 °C		
Wire ranges screw terminals,	fine-stranded / solid	1 x 0.2 mm ² – 2.5 mm ² / 2 x 0.2 mm ² – 1.0 mm ²	
	fine-stranded with ferrules	1 x 0.25 mm ² – 2.5 mm ² / 2 x 0.25 mm ² – 1.0 mm ²	
Permissible torque	0.5 - 0.6 Nm		
Wire ranges Push-in terminals	1 x 0.25 mm ² – 1.5 mm ²		
Weight	0.20 kg / 0.25 kg		
Standards	EN ISO 13849-1, EN 62061, EN 574		
Approvals	TÜV, cULus, CCC		

SNZ 1022K

TWO-HAND RELAY TYPE IIIA



APPLICATIONS

- Protection of people and machinery
- Monitoring of two-hand applications
- According to EN 574 Type IIIA
- Up to PL c / Category 1 (EN ISO 13849-1)
- Up to SIL_{CL} 1 (EN 62061)

FEATURES

- Stop Category 0 according to EN 60204-1
- Two-channel actuation; 1 NO contact and 1 NC contact for each channel
- Cross monitoring
- Monitoring of synchronous activation
- 1 changeover contact

FUNCTION

After the power supply is established at terminals A1/A2 the release current paths are closed when the actuators (S1+S2) are operated at the same time. The two actuators must be operated within 0.5 s to trigger a release. If just one of the two actuators is released, the device is immediately de-energized and the enabling current path is opening.

The device can only be restarted once the two actuators are returned to their initial positions (e.g. the two-hand buttons have been released). The current status of the device is shown by 2 LEDs. The presence of the power supply is indicated with the SUPPLY LED, the operation of the two actuators with the K1 LED, if there is synchronous operation.

CIRCUIT DIAGRAM

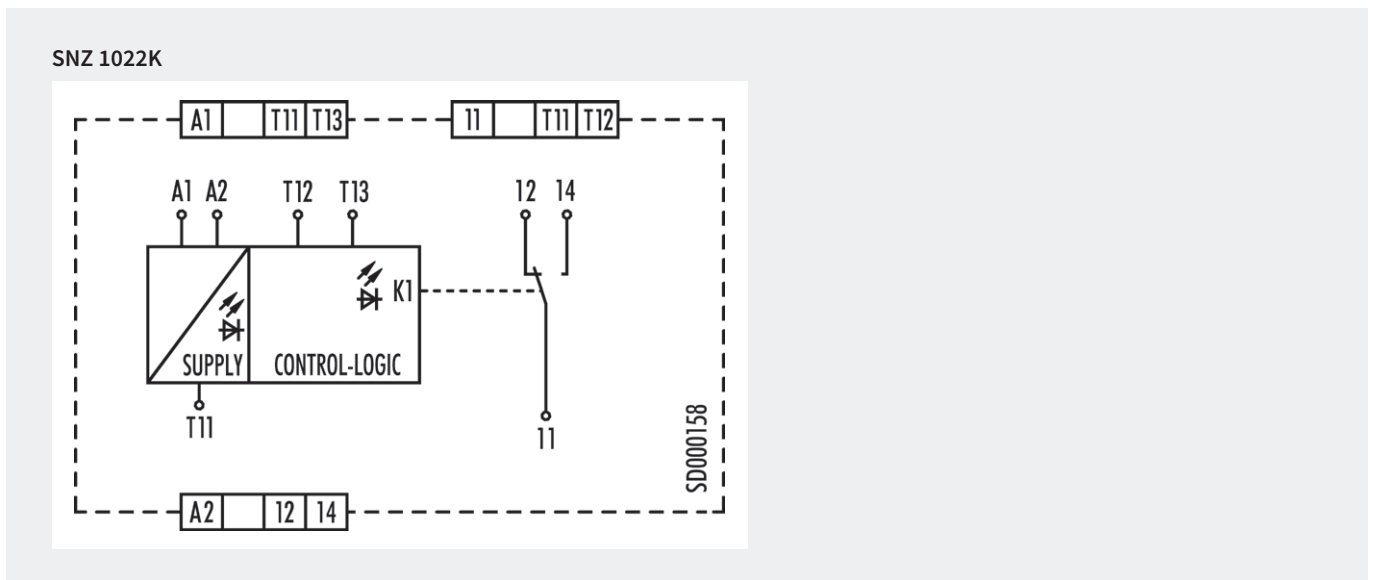



OVERVIEW OF DEVICES | PART NUMBERS

Type	Rated Voltage	Synchronous time	Terminals	Part no.	P.U.
SNZ 1022K-A	24 V AC/DC	0.5 s	Screw terminals, pluggable	R1.188.3700.0	1
SNZ 1022K-A	115-230 V AC	0.5 s	Screw terminals, pluggable	R1.188.3710.0	1
SNZ 1022K-C	24 V AC/DC	0.5 s	Push-in terminals, pluggable	R1.188.3720.0	1
SNZ 1022K-C	115-230 V AC	0.5 s	Push-in terminals, pluggable	R1.188.3730.0	1

TECHNICAL DATA		
Function	Two-hand control relay	
Function display	2 LEDs, green	
Power supply circuit		
Rated voltage U_N	A1, A2	24 V AC/DC / 115-230 V AC
Rated consumption	AC/DC 24 V	0.7 W / 2.0 VA
	AC 115-230 V	3 VA
Rated frequency	50 - 60 Hz	
Operating voltage range U_B	0.85 - 1.1 x U_N	
Electrical isolation supply circuit - control circuit	yes (at $U_N = 115-230$ V AC)	
Control circuit		
Rated output voltage	T11	24 V DC
Input current / peak current	T12	2.5 mA / 3 mA
	T13	25 mA / 60 mA
Response time t_{A1} / t_{A2}	< 20 ms	
Recovery time t_W	> 250 ms	
Release time t_R	< 20 ms	
Synchronous time t_S	≤ 500 ms	
Max. resistivity, per channel	$(5 + (1.176 \times U_B / U_N - 1) \times 100) \Omega$	
Output circuit		
Enabling paths	11/12/14	changeover contact
Contact type	Ag-alloy, gold-plated	
Rated switching voltage	230 V AC	
Max. thermal current I_{th}	enabling path 10/12	6 A
Application category (NO)	AC-15	U_e 230 V, I_e 3 A
	DC-13	U_e 24 V, I_e 2 A
Short-circuit protection (NO), lead fuse / circuit breaker	6 A class gG / melting integral < 100 A ² s	
Mechanical life	10 x 10 ⁶ switching cycles	
General data		
Creepage distances and clearances between the circuits	EN 60664-1	
Protection degree according to EN 60529 (housing / terminals)	IP40 / IP20	
Ambient temperature / storage temperature	-25 °C - +55 °C / -25 °C - + 75 °C	
Wire ranges screw terminals,	fine-stranded / solid	1 x 0.2 mm ² - 2.5 mm ² / 2 x 0.2 mm ² - 1.0 mm ²
	fine-stranded with ferrules	1 x 0.25 mm ² - 2.5 mm ² / 2 x 0.25 mm ² - 1.0 mm ²
Permissible torque	0.5 - 0.6 Nm	
Wire ranges push-in terminals	2 x 0.25 mm ² - 1.5 mm ²	
Weight	24 V AC/DC device / AC device	0.1 kg
Standards	EN ISO 13849-1, EN 62061, EN 574	
Approvals	TÜV, cULus, CCC	

SNV 4063KL

MONITORING OF EMERGENCY STOP, SAFETY GATES AND LIGHT BARRIERS, OFF-DELAYED



APPLICATIONS

- Protection of people and machinery
- Monitoring of emergency stop applications
- Monitoring of safety gates
- Monitoring of light barriers
- Termination of braking operations through OFF-delay time
- Control of solenoid-actuated interlocks
- Up to PL e / Category 4 (EN ISO 13849-1) for undelayed contacts
- Up to PLd / Category 3 (EN ISO 13849-1) for delayed contacts
- Up to SILCL 3 (EN 62061)

FEATURES

- Stop category 0/1 according to EN 60204-1
- Single-channel or two-channel control
- Manual or automatic start
- OFF-delay time adjustable in the range 0.15 to 3s or 1.5 to 30s
- Reset button monitoring, cross monitoring, monitoring of synchronous time
- 3 enabling current paths (2 undelayed, 1 OFF-delayed)

FUNCTION

With the supply voltage applied to terminals A1/A2 and the emergency set right and left margins in-line button. This controls relays K1 to K4, which become self-locking (when starting via reset button monitoring after the response time). After this switch-on phase the 3 enabling current paths are closed (terminals 13/14, 23/24 and 37/38). Three LEDs display the state of relays K1/K2, K3/K4 and the supply voltage.

If the emergency stop button is activated, the current supplies for relays K1 to K4 are interrupted. The undelayed enabling current paths (terminals 13/14, 23/24) are opened with release time t_{R1} while the off-delayed enabling current path (terminals 37/38) is opened after the pre-set OFF-delay time t_{R2} . The OFF-delay time can be adjusted infinitely in the range 0.15 to 3 s or 1.5 to 30 s.

With a two-channel control and cross-monitoring wiring of the sensor circuit, additional errors such as short-circuit or ground fault can be detected. An electronic fuse protects the device against damage. After the cause of the malfunction has been removed, the device is operational again after approx. 3 s.

- **Reset button monitoring** – The device can be started either with the falling edge or with the rising edge (terminals S34 or S35). For emergency stop applications with manual start the button must be connected to terminals S33/S34. The device is enabled only with the falling edge of the reset signal. For starting, the reset button must be pressed and released. For safety gate applications in which an automatic start is performed it is necessary to bridge terminals S33/S35. The device will react at the rising edge of input S12 which is internally connected to S33.
- **Monitoring of synchronous time** – The use of safety limit switches for single-channel or two-channel circuits in safety gate applications depends on the required safety level. The device provides a monitoring of the synchronous time of two connected safety switches. A synchronous time $t_s \approx 0.5$ s requires limit switches positioned in such a way that channel 1, terminals S11/S12, closes before channel 2, terminals S21/S22. If channel 2 closes before channel 1, the synchronous time is $t_s = \infty$.

CIRCUIT DIAGRAM

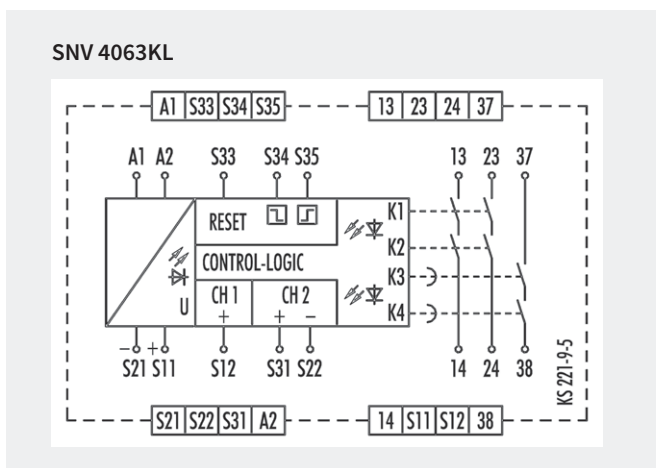



OVERVIEW OF DEVICES | PART NUMBERS

Type	Time range	Rated voltage	Terminals	Part no.	P.U.
SNV 4063KL-A	3 s	24 V DC	Screw terminals, pluggable	R1.188.0620.0	1
	30 s	24 V DC	Screw terminals, pluggable	R1.188.0640.0	1
	150 s	24 V DC	Screw terminals, pluggable	R1.188.4100.0	1
SNV 4063KL-C	3 s	24 V DC	Push-in terminals, pluggable	R1.188.2010.0	1
	30 s	24 V DC	Push-in terminals, pluggable	R1.188.3900.0	1

TECHNICAL DATA

Function	Emergency stop relay for controlled stop	
Function display	3 LEDs, green	
Function mode / adjustment	Time / stepless	
Adjustment range	0.15 - 3 s / 1.5 - 30 s / 7.5 - 150 s	
Power supply circuit		
Rated voltage U_N	A1, A2	24 V DC
Rated consumption	24 V DC	2.6 W
Operating voltage range U_B	0.85 - 1.1 x U_N	
Electrical isolation supply circuit - control circuit	no	
Control circuit		
Rated output voltage	S11, S33/S21	22 V DC
Input current / peak current	S12, S31/S22	25 mA / 100 mA
	S34, S35	40 mA / 50 mA
Response time t_{A1} / t_{A2}	30 ms / 700 ms	
Minimum ON time t_M	200 ms	
Recovery time t_W	500 ms	
Release time t_R	25 ms	
Release time t_{R1} , delayed contacts (tolerance)	0.15 - 3 s / 1.5 - 30 s ($\pm 16\%$)	
Synchronous time t_S	500 ms	
Permissible test pulse time t_{TP}	< 1 ms	
Max. resistivity, per channel ¹⁾	$\leq (5 + (1.176 \times U_B / U_N - 1) \times 100) \Omega$	
Output circuit		
Enabling paths	13/14, 23/24	normally open contact
	37/38	normally open contact, OFF-delayed
Contact assignment	forcefully guided	
Contact type	Ag-alloy, gold-plated	
Rated switching voltage	enabling path	230 V AC
Max. thermal current I_{th}	enabling path	6 A
Max. total current I^2 of all current path	($T_u = 55^\circ C$)	5 A ²
Application category (NO)	AC-15	U_e 230 V, I_e 3 A
	DC-13	U_e 24 V, I_e 2 A
Short-circuit protection (NO), lead fuse / circuit breaker	6 A Class gG / melting integral < 100 A ² s	
Mechanical life	10 ⁷ switching cycles	
General data		
Creepage distances and clearances between the circuits	EN 60664-1	
Protection degree according to EN 60529 (housing / terminals)	IP40 / IP20	
Ambient temperature / storage temperature	-25 °C - +55 °C / -25 °C - +75 °C	
Wire ranges screw terminals,	fine-stranded / solid	1 x 0.2 mm ² - 2.5 mm ² / 2 x 0.2 mm ² - 1.0 mm ²
	fine-stranded with ferrules	1 x 0.25 mm ² - 2.5 mm ² / 2 x 0.25 mm ² - 1.0 mm ²
Permissible torque	0.5 - 0.6 Nm	
Wire ranges push-in terminals	1 x 0.25 mm ² - 1.5 mm ²	
Weight	0.20 kg	
Standards	EN ISO 13849-1, EN 62061, EN 50156-1	
Approvals	TÜV, GL, cULus, CCC	

¹⁾ If two-channel devices are installed as single channel, the value is halved.

SNV 4063KP

MONITORING OF EMERGENCY STOP, SAFETY GATES AND LIGHT BARRIERS, ON-DELAYED



APPLICATIONS

- Protection of people and machinery
- Monitoring of emergency stop applications
- Monitoring of safety gates
- Monitoring of light barriers
- Monitoring of interlocking installation with position switches and integrated locking
- Control of spring-actuated interlocks
- Up to PL e / Category 4 (EN ISO 13849-1)
- Up to SIL_{CL} 3 (EN 62061)

FEATURES

- Stop Category 0 according to EN 60204-1
- Single-channel or two-channel control
- Manual or automatic start
- ON-delay time adjustable in the range 0.15 to 3 s or 1.5 to 30 s
- Reset button monitoring, cross monitoring
- 3 enabling current paths (2 undelayed, 1 ON-delayed)

FUNCTION

With supply voltage applied to terminals A1/A2, relays K3 and K4 (terminals 37/38) start with the pre-selected ON-delay time. The ON-delay time t_{A1} can be adjusted infinitely in the range 0.15 to 3 s or 1.5 to 30 s according to the device type. The device is enabled by pressing the reset button. The following operating modes can be selected:

- **Manual start** – The reset button must be connected to S34 through terminal S33. For starting the relay, the reset button must be pressed. Relays K3 and K4 (terminals 37/38) will switch into the OFF position. With the falling edge of the reset signal, the reset is completed and activates relays K1 and K2, which become self-locking after the response time t_{A3} . After this switch-on phase, the 2 enabling current paths defined for the output are closed (terminals 13/14, 23/24). With the emergency stop command, the power supply to relays K1 and K2 is interrupted. The enabling current paths (terminals 13/14, 23/24) are immediately opened with release time t_R , and relays K3 and K4 will start after the pre-set ON-delay time t_{A1} , terminals 37/38. Three LEDs display the state of relays K1/K2, K3/K4 and the supply voltage.
- **Automatic start** – For monitoring of interlocking installations with locking mechanism or safety gate applications in which on automatic start shall be performed it is necessary to jumper terminals S33/S35. The device will react at the rising edge of input S12 that is internally connected to S33. Relays K3 and K4 (terminals 37/38) will switch into the OFF position. With the rising edge of input S12 the relay K1 is activated and response time t_{A2} started. When the time has elapsed, the 2 enabling current paths are closed (terminals 13/14, 23/24). With a stop command the power supply to relays K1 and K2 is interrupted. The enabling current paths (terminals 13/14, 23/24) are immediately opened with release time t_R , and relays K3 and K4 will start after the pre-set ON-delay time t_{A1} , terminals 37/38.

CIRCUIT DIAGRAM

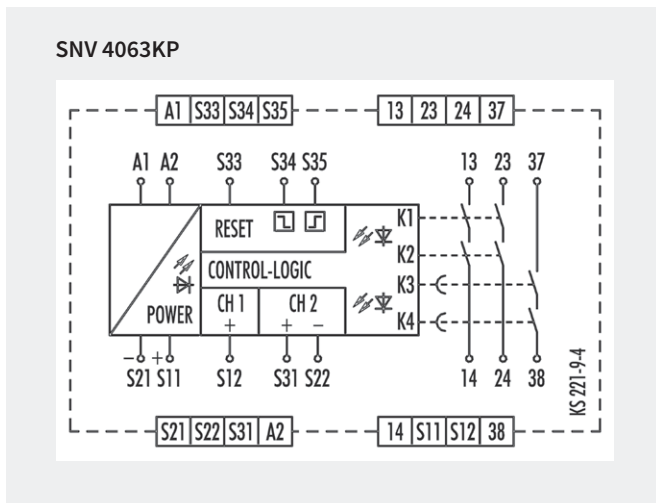



OVERVIEW OF DEVICES | PART NUMBERS

Type	Time range	Rated voltage	Terminals	Part no.	P.U.
SNV 4063KP-A	3 s	24 V DC	Screw terminals, pluggable	R1.188.0660.0	1
	30 s	24 V DC	Screw terminals, pluggable	R1.188.0680.0	1

TECHNICAL DATA			
Function	Emergency stop relay for access delay combined with locking mechanism		
Function display	3 LEDs, green		
Function mode / adjustment	Time / stepless		
Adjustment range	0.15 - 3 s / 1.5 - 30 s		
Power supply circuit			
Rated voltage U_N	A1, A2	24 V DC	
Rated consumption	24 V DC	2.6 W	
Operating voltage range U_B	0.85 - 1.1 x U_N		
Electrical isolation supply circuit - control circuit	no		
Control circuit			
Rated output voltage	S11, S33/S21	22 V DC	
Input current / peak current	S12, S31/S22	25 mA / 100 mA	
	S34, S35	40 mA / 50 mA	
Response time t_{A1} / t_{A2}	30 ms / 700 ms		
Minimum ON time t_M	200 ms		
Recovery time t_W	500 ms		
Release time t_R	25 ms		
Release time t_{R1} , delayed contacts (tolerance)	0.15 - 3 s / 1.5 - 30 s ($\pm 16\%$)		
Synchronous time t_S	500 ms		
Permissible test pulse time t_{TP}	< 1 ms		
Max. resistivity, per channel ¹⁾	$\leq (5 + (1.176 \times U_B / U_N - 1) \times 100) \Omega$		
Output circuit			
Enabling paths	13/14, 23/24	normally open contact	
	37/38	normally open contact, ON-delayed	
Contact assignment	forcefully guided		
Contact type	Ag-alloy, gold-plated		
Rated switching voltage	enabling path	230 V AC	
Max. thermal current I_{th}	enabling path	6 A	
Max. total current I^2 of all current path	($T_u = 55^\circ\text{C}$)	5 A ²	
Application category (NO)	AC-15	U_e 230 V, I_e 3 A	
	DC-13	U_e 24 V, I_e 2 A	
Short-circuit protection (NO), lead fuse / circuit breaker	6 A Class gG / melting integral < 100 A ² s		
Mechanical life	10 ⁷ switching cycles		
General data			
Creepage distances and clearances between the circuits	EN 60664-1		
Protection degree according to EN 60529 (housing / terminals)	IP40 / IP20		
Ambient temperature / storage temperature	-25 °C - +55 °C / -25 °C - +75 °C		
Wire ranges screw terminals,	fine-stranded / solid	1 x 0.2 mm ² - 2.5 mm ² / 2 x 0.2 mm ² - 1.0 mm ²	
	fine-stranded with ferrules	1 x 0.25 mm ² - 2.5 mm ² / 2 x 0.25 mm ² - 1.0 mm ²	
Permissible torque	0,5 - 0,6 Nm		
Wire ranges push-in terminals	1 x 0.25 mm ² - 1.5 mm ²		
Weight	0.20 kg		
Standards	EN ISO 13849-1, EN 62061, EN 50156-1		
Approvals	TÜV, GL, cULus, CCC		

¹⁾ If two-channel devices are installed as single channel, the value is halved.

SNV 4074SL / SNV 4076SL

MONITORING OF EMERGENCY STOP, SAFETY GATES AND LIGHT BARRIERS, OFF-DELAYED



APPLICATIONS

- Controlled stop according to Category 1 (EN 60204-1)
- Monitoring of emergency stop applications
- Monitoring of safety gates
- Monitoring of interlocks
- Monitoring of light barriers
- Up to PL e / Category 4 (EN ISO 13849-1)
- Up to SIL_{CL} 3 (EN 62061)

FEATURES

- Stop Category 0/1 according to EN 60204-1
- Time setting in 10 steps
- Time ranges 3s, 30s or 300s
- Single-channel or two-channel control
- Manual or automatic start
- SafeStart
- Cross monitoring

OFF-DELAY FUNCTION

After the supply voltage is applied to terminals A1/A2 and the safety inputs are closed, the enabling current paths (NO contacts) are closed automatically or by pressing the reset button (manual start). When the safety inputs are opened/de-energized the enabling current paths (NO contacts) are opened immediately or with a delay.

- **Automatic start** – Reset input S14 is connected to safety input S12. To monitor external contact blocks (EDM), their NC contacts must be connected in series between S34 and S12.
- **Manual start without monitoring** – Reset input S14 is connected to safety input S12 via a reset button. To monitor external contact blocks (EDM), their NC contacts must be connected in series to the reset button.
- **Manual start with monitoring** – Reset input S34 is connected to safety input S11 via a reset button. To monitor external contact blocks (EDM), their NC contacts must be connected in series to the reset button.

CIRCUIT DIAGRAMS

SNV 4074SL

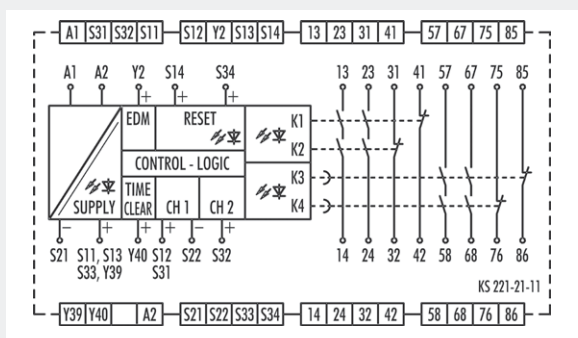

SNV 4076SL

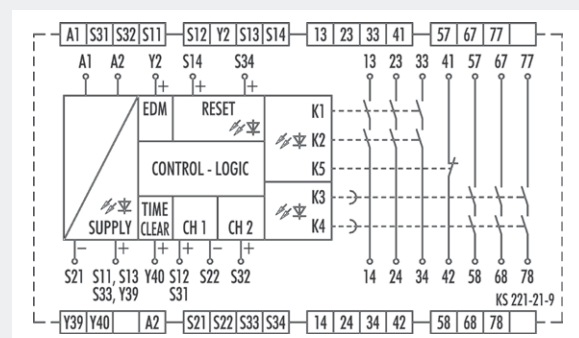



OVERVIEW OF DEVICES | PART NUMBERS

Type	Time range	Rated voltage		Terminals	Part no. 24 V DC	Part no. 115 – 230 V AC	P.U.
SNV 4074SL-A	3s	24V DC	115 – 230 V AC	Screw terminals, pluggable	R1.188.2130.0	R1.188.2310.0	1
SNV 4074SL-A	30s	24V DC	115 – 230 V AC	Screw terminals, pluggable	R1.188.2160.0	R1.188.2340.0	1
SNV 4074SL-A	300s	24V DC	115 – 230 V AC	Screw terminals, pluggable	R1.188.2190.0	R1.188.2370.0	1
SNV 4074SL-C	3s	24V DC	115 – 230 V AC	Push-in terminals, pluggable	R1.188.2140.0	R1.188.2320.0	1
SNV 4074SL-C	30s	24V DC	115 – 230 V AC	Push-in terminals, pluggable	R1.188.2170.0	R1.188.2350.0	1
SNV 4074SL-C	300s	24V DC	115 – 230 V AC	Push-in terminals, pluggable	R1.188.2200.0	R1.188.2380.0	1
SNV 4076SL-A	3s	24V DC	115 – 230 V AC	Screw terminals, pluggable	R1.188.2040.0	R1.188.2220.0	1
SNV 4076SL-A	30s	24V DC	115 – 230 V AC	Screw terminals, pluggable	R1.188.2070.0	R1.188.2250.0	1
SNV 4076SL-A	300s	24V DC	115 – 230 V AC	Screw terminals, pluggable	R1.188.2100.0	R1.188.2280.0	1
SNV 4076SL-C	3s	24V DC	115 – 230 V AC	Push-in terminals, pluggable	R1.188.2050.0	R1.188.2230.0	1
SNV 4076SL-C	30s	24V DC	115 – 230 V AC	Push-in terminals, pluggable	R1.188.2080.0	R1.188.2260.0	1
SNV 4076SL-C	300s	24V DC	115 – 230 V AC	Push-in terminals, pluggable	R1.188.2110.0	R1.188.2290.0	1

TECHNICAL DATA			
Function	Emergency stop relay		
Function display	5 LEDs, green/red		
Function mode / adjustment	Time setting in 10 steps		
Adjustment range	0.1 - 3 s / 0 - 30 s / 0 - 300 s		
Power supply circuit			
Rated voltage U_N	A1, A2	24 V DC / 115-230 V AC	
Rated consumption	24 V DC 115-230 V AC	2.8 W 3.2 W / 6,3 VA	
Rated frequency	50 - 60 Hz		
Operating voltage range U_B	0.85 - 1.1 x U_N		
Electrical isolation supply circuit - control circuit	yes (at U_N = AC 115-230 V)		
Control circuit			
Rated output voltage	S11, S13, S33, Y39 / S21	22 V DC	
Input current / peak current	S12, S31/S22, S32	3 mA / 4.5 mA	
	S14, S34, Y2, Y40	4 mA / 4.5 mA	
Response time t_{A1} / t_{A2}	200 ms		
Minimum ON time t_M	100 ms		
Recovery time t_W	50 ms		
Release time t_R	20 ms		
Release time t^R , delayed contacts (tolerance)	0.1 / 0.2 / 0.3 / 0.4 / 0.5 / 0.8 / 1 / 1.5 / 2 / 3 s (0.1 % ± 15 ms) 0 / 2 / 4 / 6 / 0.5 / 8 / 10 / 15 / 20 / 30 s (0.1 % ± 15 ms) 0 / 20 / 40 / 60 / 80 / 100 / 150 / 200 / 250 / 300 s (0.1 % ± 15 ms)		
Permissible test pulse time t_{TP}	< 1 ms		
Max. resistivity, per channel ¹⁾	24 V DC 115-230 V AC	< 50 Ω < 50 Ω	
Output circuit			
Enabling paths	13/14, 23/24, 33/34 57/58, 57/68, 77/78	normally open contact normally open contact, OFF-delayed	
Signaling paths	31/32, 41/42 75/76, 85/86	normally closed contact normally closed contact, OFF-delayed	
Contact assignment	forcefully guided		
Contact type	Ag-alloy, gold-plated		
Rated switching voltage	enabling- / signaling path	230 V AC	
Max. thermal current I_{th}	enabling- / signaling path	6 A / 2 A	
Max. total current I^2 of all current path ($T_u = 55^\circ\text{C}$)	40 A ²		
Application category (NO)	AC-15 DC-13	U_e 230 V, I_e 3 A U_e 24 V, I_e 3 A	
Short-circuit protection (NO), lead fuse / circuit breaker	6 A class gG / melting integral < 100 A ² s		
Mechanical life	10 ⁷ switching cycles		
General data			
Creepage distances and clearances between the circuits	EN 60664-1		
Protection degree according to EN 60529 (housing / terminals)	IP40 / IP20		
Ambient temperature / storage temperature	-25 °C - +55 °C / -25 °C - +75 °C		
Wire ranges screw terminals,	fine-stranded / solid	1 x 0.2 mm ² – 2.5 mm ² / 2 x 0.2 mm ² – 1.0 mm ²	
	fine-stranded with ferrules	1 x 0.25 mm ² – 2.5 mm ² / 2 x 0.25 mm ² – 1.0 mm ²	
Permissible torque	0.5 - 0.6 Nm		
Wire ranges push-in terminals	1 x 0.25 mm ² – 1.5 mm ²		
Weight	0.33 kg / 0.35 kg		
Standards	EN ISO 13849-1, EN 62061, EN 50156-1		
Approvals	TÜV, GL, cULus, CCC		

¹⁾ If two-channel devices are installed as single channel, the value is halved.

SNV 4274SL / SNV 4074ST – MONITORING OF EMERGENCY STOP, LIGHT BARRIERS AND SAFETY GATES, OFF-DELAYED/ON-DELAYED



APPLICATIONS

- Monitoring of limit values in the process industry
- Monitoring of emergency stop applications
- Monitoring of safety gates
- Monitoring of interlocks
- Monitoring of light barriers
- Up to PL e / Category 4 (EN ISO 13849-1)
- Up to SIL_{CL} 3 (EN 62061)

FEATURES

- Continuously adjustable, analog time setting
- Time ranges 3s, 30s or 300s
- Retriggering of the time delay possible
- Single-channel or two-channel control
- Manual or automatic start
- SafeStart
- Cross monitoring

OFF-DELAY WITH RETRIGGERING FUNCTION (SNV 4274SL)

After the supply voltage is applied to terminals A1/A2 and the safety inputs are closed, the contacts are switched on immediately, either automatically or by pressing the reset button (manual start). When the safety inputs are opened/de-energized, the contacts are switched off immediately or with a release delay.

The set release delay only expires if the safety inputs are opened longer than the release delay set on the device. If the safety inputs are closed again before the release delay has expired (retriggering), the delayed contacts will remain closed, too.

ON-DELAY FUNCTION (SNV 4074ST)

After the supply voltage is applied to terminals A1/A2 and the safety inputs are closed, the contacts are switched on immediately or with a response delay, either automatically or by pressing the reset button (manual start). When the safety inputs are opened/de-energized the contacts are switched off immediately.

CIRCUIT DIAGRAMS

SNV 4274SL

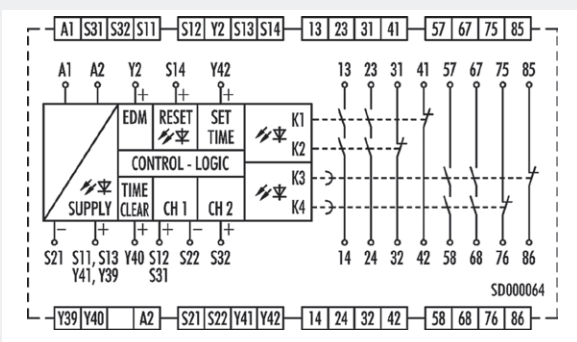

SNV 4074ST

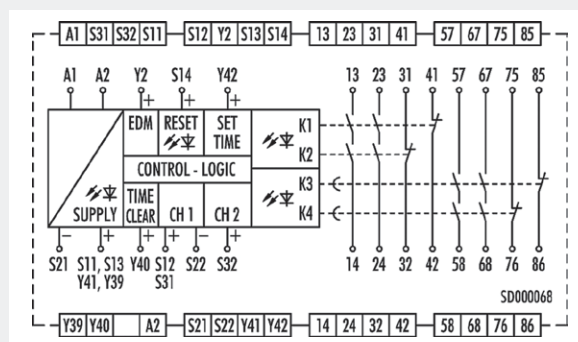



OVERVIEW OF DEVICES | PART NUMBERS

Type	Time range	Rated voltage		Terminals	Part no. 24V DC	Part no. 115 – 230V AC	P.U.
SNV 4274SL-A	3s	24V DC	115 – 230V AC	Screw terminals, pluggable	R1.188.2470.0	R1.188.2650.0	1
SNV 4274SL-A	30s	24V DC	115 – 230V AC	Screw terminals, pluggable	R1.188.2500.0	R1.188.2680.0	1
SNV 4274SL-A	300s	24V DC	115 – 230V AC	Screw terminals, pluggable	R1.188.2530.0	R1.188.2710.0	1
SNV 4274SL-C	3s	24V DC	115 – 230V AC	Push-in terminals, pluggable	R1.188.2480.0	R1.188.2660.0	1
SNV 4274SL-C	30s	24V DC	115 – 230V AC	Push-in terminals, pluggable	R1.188.2510.0	R1.188.2690.0	1
SNV 4274SL-C	300s	24V DC	115 – 230V AC	Push-in terminals, pluggable	R1.188.2540.0	R1.188.2720.0	1
SNV 4074ST-A	3s	24V DC	115 – 230V AC	Screw terminals, pluggable	R1.188.2560.0	R1.188.2740.0	1
SNV 4074ST-A	30s	24V DC	115 – 230V AC	Screw terminals, pluggable	R1.188.2590.0	R1.188.2770.0	1
SNV 4074ST-A	300s	24V DC	115 – 230V AC	Screw terminals, pluggable	R1.188.2620.0	R1.188.2800.0	1
SNV 4074ST-C	3s	24V DC	115 – 230V AC	Push-in terminals, pluggable	R1.188.2570.0	R1.188.2750.0	1
SNV 4074ST-C	30s	24V DC	115 – 230V AC	Push-in terminals, pluggable	R1.188.2600.0	R1.188.2780.0	1
SNV 4074ST-C	300s	24V DC	115 – 230V AC	Push-in terminals, pluggable	R1.188.2630.0	R1.188.2810.0	1

TECHNICAL DATA			
Function	Emergency stop relay		
Function display	5 LEDs, green/red		
Function mode / adjustment	Time / stepless		
Adjustment range	0.15 - 3 s / 1.5 - 30 s / 15 - 300 s		
Power supply circuit			
Rated voltage U_N	A1, A2	24 V DC / 115-230 V AC	
Rated consumption	24 V DC 115-230 V AC	2.8 W 3.2 W / 6.3 VA	
Rated frequency	50 - 60 Hz		
Operating voltage range U_B	0.85 - 1.1 x U_N		
Electrical isolation supply circuit - control circuit	yes (at $U_N = 115-230$ V AC)		
Control circuit			
Rated output voltage	S11, S13, S33, Y39 / S21	22 V DC	
Input current / peak current	S12, S31/S22, S32	3 mA / 4,5 mA	
	S14, S34, Y2, Y40	4 mA / 4,5 mA	
Response time t_{A1} / t_{A2}	200 ms		
Minimum ON time t_M	100 ms		
Recovery time t_W	50 ms		
Release time t_R	20 ms		
Release time t_{R1} , delayed contacts (tolerance)	0,15 - 3 s (± 16 % of the setting value)		
	1,5 - 30 s (± 16 % of the setting value)		
	15 - 300 s (± 16 % of the setting value)		
Permissible test pulse time t_{TP}	< 1 ms		
Max. resistivity, per channel ¹⁾	24 V DC 115-230 V AC	< 50 Ω < 50 Ω	
Output circuit			
Enabling paths	13/14, 23/24	normally open contact	
	57/58, 57/68	normally open contact, time delayed	
Signaling paths	31/32, 41/42 75/76, 85/86	normally closed contact	normally closed contact, time delayed
Contact assignment	forcefully guided		
Contact type	Ag-alloy, gold-plated		
Rated switching voltage	enabling- / signaling path	230 V AC	
Max. thermal current I_{th}	enabling- / signaling path	6 A / 2 A	
Max. total current I^2 of all current path ($T_u = 55$ °C)	40 A ²		
Application category (NO)	AC-15 DC-13	U_e 230 V, I_e 3 A U_e 24 V, I_e 3 A	
Short-circuit protection (NO), lead fuse / circuit breaker	6 A class gG / melting integral < 100 A ² s		
Mechanical life	10 ⁷ switching cycles		
General data			
Creepage distances and clearances between the circuits	EN 60664-1		
Protection degree according to EN 60529 (housing / terminals)	IP40 / IP20		
Ambient temperature / storage temperature	-25 °C - +55 °C / -25 °C - + 75 °C		
Wire ranges screw terminals,	fine-stranded / solid	1 x 0.2 mm ² – 2.5 mm ² / 2 x 0.2 mm ² – 1.0 mm ²	
	fine-stranded with ferrules	1 x 0.25 mm ² – 2.5 mm ² / 2 x 0.25 mm ² – 1.0 mm ²	
Permissible torque	0.5 - 0.6 Nm		
Wire ranges push-in terminals	1 x 0.25 mm ² – 1.5 mm ²		
Weight	0,33 kg / 0,35 kg		
Standards	EN ISO 13849-1, EN 62061, EN 50156-1		
Approvals	TÜV, GL, cULus, CCC		

¹⁾ If two-channel devices are installed as single channel, the value is halved.

SNE 1

CONTACT EXPANSION

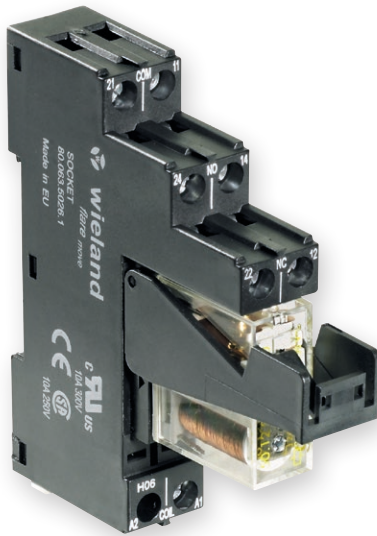

APPLICATIONS

- Duplication of the enabling current paths of a basic device
- Contact expansion in safety-oriented systems
- Up to PL e / Category 4 (EN ISO 13849-1)*
- Up to SIL_{CL} 3 (EN 62061)*

FEATURES

- Stop Category 0 and 1 according to EN 60204-1
- Single-channel operation
- 2 changeover contacts (positively driven)
- Sturdy retaining bracket

* Depends on the category of the basic device or the safety control.

CIRCUIT DIAGRAM

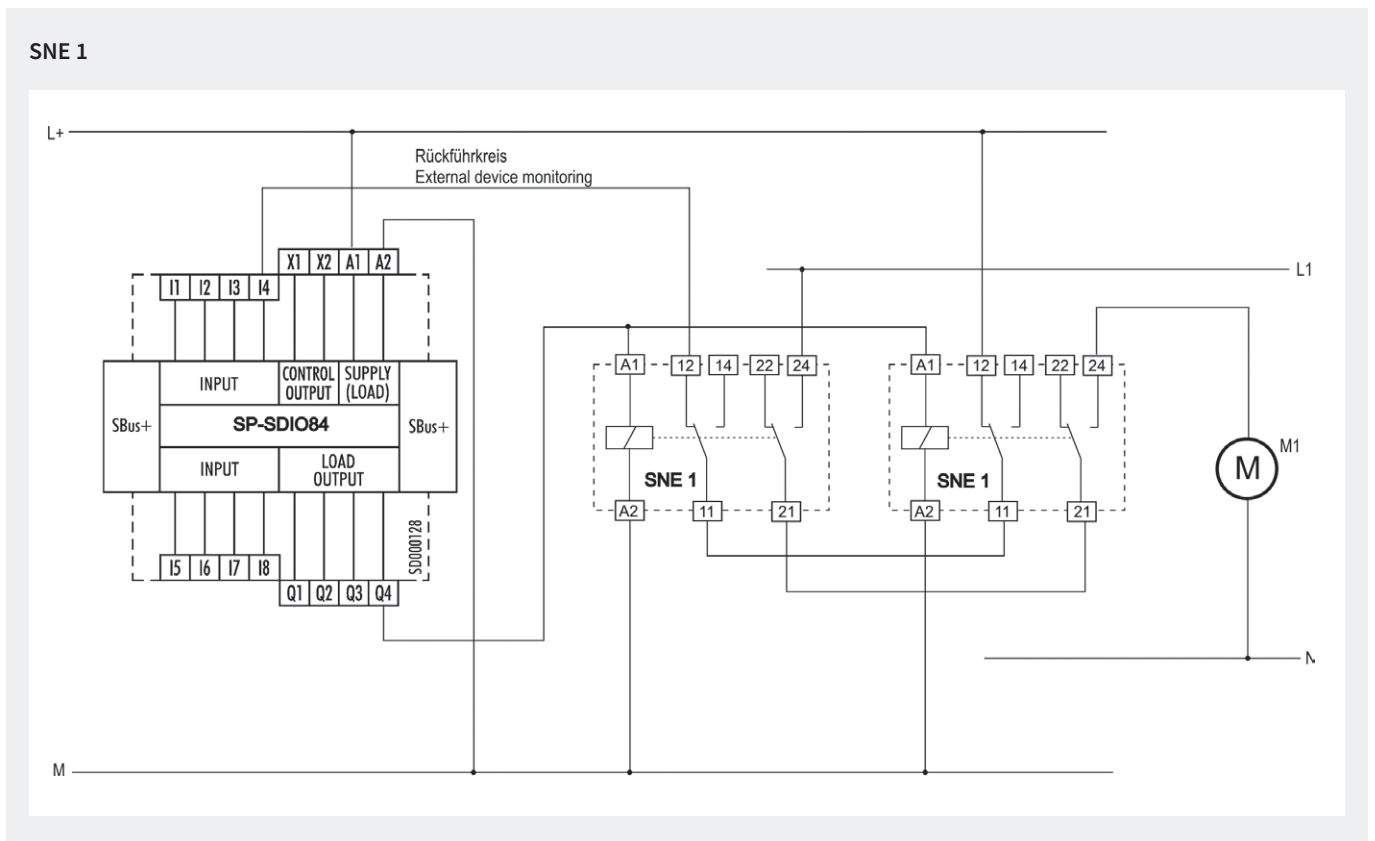

OVERVIEW OF DEVICES | PART NUMBERS

Type	Rated voltage	Terminals	Part no.	P.U.
SNE 1	24 V DC	Screw terminals	R1.188.3950.0	1

CIRCUIT DIAGRAM

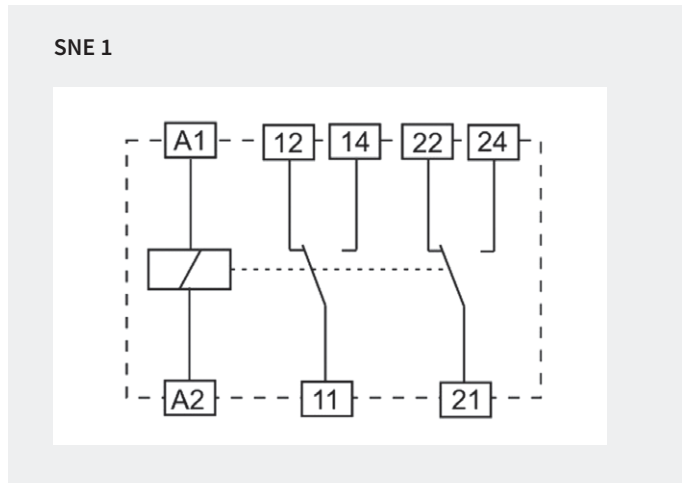

TECHNICAL DATA		
Function		Emergency stop expansion relay
Function display		none
Power supply circuit		
Rated voltage U_N	A1/A2	24 V DC
Rated consumption		0.7 W
Operating voltage range U_B		0.63 - 1.25 x U_N
Electrical isolation supply circuit - control circuit		yes
Control circuit		
Input current / peak current	A1/A2	ca. 29 mA
Response time t_{A1} / t_{A2}		12 ms
Release time t_R		< 20 ms
Output circuit		
Enabling paths	11/12/14, 21/22/24	changeover contact
Contact assignment		forcebly guided
Contact type		Ag-alloy
Rated switching voltage		230 V AC, 24 V DC
Max. thermal current I_{th}		8 A
Max. total current I^2 of all current path	($T_u = 55^\circ\text{C}$)	72 A ²
Application category (NO)	AC-15	U_e 230 V, I_e 2 A
	DC-13	U_e 24 V, I_e 3 A
Short-circuit protection (NO), lead fuse / circuit breaker		6 A class gL / melting integral < 100 A ² s
Mechanical life		10 x 10 ⁶ switching cycles
General data		
Creepage distances and clearances between the circuits		EN 61810-5
Protection degree according to EN 60529 (housing / terminals)		IP20 / IP20
Ambient temperature / storage temperature		-40 °C - +70 °C / -40 °C - + 70
Wire range	fine-stranded / solid	0.25 mm ² – 4.0 mm ² (AWG 24-12) / 0.25 – 6.0 mm ² (AWG 24-10)
Permissible torque		0.5 Nm
Weight		0.06 kg
Standards		EN 50205 (Type B)
Approvals		cURus

SNE 4003K

CONTACT EXPANSION



APPLICATIONS

- Duplication of the enabling current paths of a basic device
- Contact expansion in safety-oriented systems
- Contact expansion for light curtains
- Up to PL e / Category 4 (EN ISO 13849-1)*
- Up to SIL_{CL} 3 (EN 62061)*

FEATURES

- Single-channel or two-channel operation
- 3 enabling current paths (NO contact)
- 2 signaling current paths (NC contact)
- Wide input voltage range from 15 to 30 V DC
- Suitable for semiconductor outputs

* Depends on the category of the basic device or the safety control.

FUNCTION

The SNE 4003K is an expansion device for basic devices (such as safety switching devices, light curtains, laser scanners) that are part of the machine's safety equipment and are used for protecting people, materials and machines.

The device is designed with two channels and redundancy. There is basic insulation to separate the enabling current paths from one another and the control circuits from the signaling current paths. The broad input voltage range of 15 V DC to 30 V DC makes the SNE 4003K ideal for single-channel or two-channel control by semiconductors.

Input voltage to the SNE 4003K is connected via one or two enabling current paths of a basic device. When the input voltage is applied relays K1 and K2 switch into the ON position. After this switch-on phase, enabling current paths 13/14, 23/24, 33/34 are closed and feedback current path Y1/Y2 and signaling current path 41/42 are opened.

This is displayed through two LEDs, K1 and K2, which are assigned to relays K1 and K2. If the enabling current paths of the basic device are opened when the emergency stop button is pressed, relays K1 and K2 on the SNE 4003K switch back into the OFF-position. The enabling current paths open and the feedback current path closes. Feedback current path Y1/Y2 prevents the basic device from switching on again before K1 or K2 releases.

CIRCUIT DIAGRAM

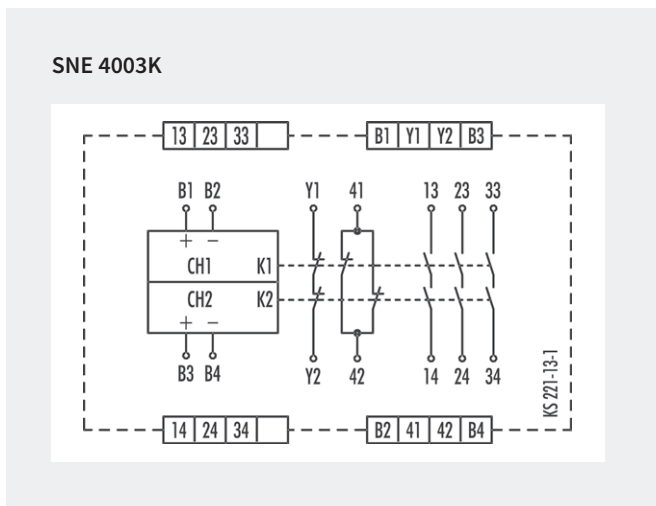



OVERVIEW OF DEVICES | PART NUMBERS

Type	Rated voltage	Terminals	Part no.	P.U.
SNE 4003K-A	24 V DC	Screw terminals, pluggable	R1.188.1340.0	1
SNE 4003K-C	24 V DC	Push-in terminals, pluggable	R1.188.4210.0	1

TECHNICAL DATA

Function	Emergency stop expansion relay		
Function display	2 LEDs, green		
Power supply circuit			
Rated voltage U_N	B1/B2, B3/B4	24 V DC	
Rated consumption	24 V DC	1.2 W	
Operating voltage range U_B	0.63 - 1.25 x U_N		
Electrical isolation supply circuit - control circuit	no		
Control circuit			
Input current / peak current	B1/B2, B3/B4	50 mA / 500 mA	
Response time t_{A1} / t_{A2}	< 40 ms		
Recovery time t_W	≤ 40 ms		
Release time t_R	< 20 ms		
Permissible test pulse time t_{TP}	< 1 ms		
Max. resistivity, per channel ¹⁾	≤ (5 + (1.6 x $U_B / U_N - 1$) x 100) Ω		
Output circuit			
Enabling paths	13/14, 23/24, 33/34	normally open contact	
Signaling paths	41/42	normally closed contact	
Contact assignment	forcefully guided		
Contact type	Ag-alloy, gold-plated		
Rated switching voltage	enabling- / signaling path	230 V AC	
	Y1/Y2	230 V AC	
Max. thermal current I_{th}	enabling- / signaling path	6 A / 2 A	
	Y1/Y2	2 A	
Max. total current I^2 of all current path	($T_u = 55^\circ\text{C}$)	9 A ²	
Application category (NO)	AC-15	U_e 230 V, I_e 3 A	
	DC-13	U_e 24 V, I_e 2,5 A	
Short-circuit protection (NO), lead fuse / circuit breaker	6 A class gG / melting integral < 100 A ² s		
Mechanical life	10 ⁷ switching cycles		
General data			
Creepage distances and clearances between the circuits	EN 60664-1		
Protection degree according to EN 60529 (housing / terminals)	IP40 / IP20		
Ambient temperature / storage temperature	-25 °C - +55 °C / -25 °C - + 75 °C		
Wire ranges screw terminals,	fine-stranded / solid	1 x 0.2 mm ² – 2.5 mm ² / 2 x 0.2 mm ² – 1.0 mm ²	
	fine-stranded with ferrules	1 x 0.25 mm ² – 2.5 mm ² / 2 x 0.25 mm ² – 1.0 mm ²	
Permissible torque	0.5 - 0.6 Nm		
Wire ranges push-in terminals	1 x 0.25 mm ² – 1.5 mm ²		
Weight	0,21 kg		
Standards	EN ISO 13849-1, EN 62061		
Approvals	DGUV, cULus, CCC		

¹⁾ If two-channel devices are installed as single channel, the value is halved.

SNE 4004K/KV

CONTACT EXPANSION



APPLICATIONS

- Expansion of a basic device's enabling current paths
- Contact expansion in safety equipment
- Up to PL d / Category 3 (EN ISO 13849-1)*
- Up to SIL_{CL} 2 (EN 62061)*

FEATURES

- Stop Category 0 and 1 according to EN 60204-1 (see "Function")
- Single-channel or two-channel control
- SNE 4004K:
 - 4 enabling current paths, undelayed (NO contact)
 - 3 signaling current paths, undelayed (NC contact)
- SNE 4004KV:
 - 4 enabling current paths, OFF-delayed (NO contact)
 - 3 signaling current paths, OFF-delayed (NC contact),
 - Time buffering

* Depends on the category of the basic device or the safety control.

FUNCTION

SNE 4004K

Supply voltage to the SNE devices is routed via an enabling current path of a basic device. When the supply voltage is applied relays K1 and K2 switch into the ON position. After this switch-on phase the four enabling current paths 13/14, 23/24, 33/34, 43/44 (of the SNE 4004K) or 17/18, 27/28, 37/38, 47/48 (of the SNE 4004KV) are closed and the feedback current path Y1/Y2 is open. This is displayed through two LEDs that are assigned to relays K1 and K2.

When the enabling current paths of the basic device are opened through the operation of the emergency stop button, relays K1 and K2 on the SNE 4004K switch back into the OFF-position. The enabling current paths open and the feedback current path closes. Feedback current path Y1/Y2 prevents the basic device from switching on again before K1 or K2 releases.

SNE 4004KV

The functions of this device correspond to those of the SNE 4004K. The SNE 4004KV is available with the following four OFF-delay times t_{r1} : 0.5 s; 1 s; 2 s and 3 s. The device has an OFF-delay time that is enabled through capacitors.

This causes the OFF-delay time t_{r1} to elapse completely even in case of failure of the power supply (A1/A2). It cannot be reset before it has elapsed. Once the delay time has elapsed, relays K1 and K2 switch into the OFF- position. OFF-delay times of > 0 s correspond to stop category 1.

CIRCUIT DIAGRAMS

SNE 4004K

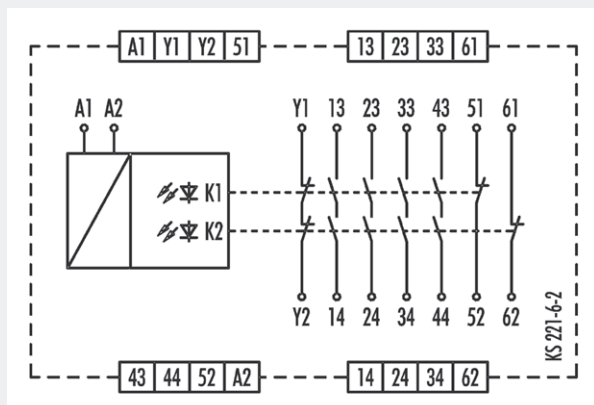

SNE 4004KV

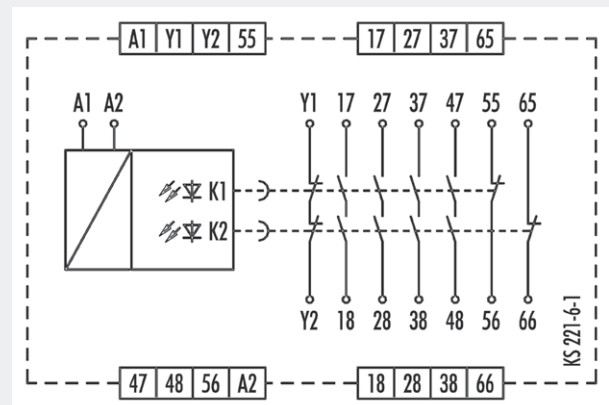



OVERVIEW OF DEVICES | PART NUMBERS

Type	Time range	Rated voltage	Terminals	Part no.	P.U.
SNE 4004K-A	–	24 V AC/DC	Screw terminals, pluggable	R1.188.0590.0	1
SNE 4004K-C	–	24 V AC/DC	Push-in terminals, pluggable	R1.188.1980.0	1
SNE 4004KV-A	0.5 s	24 V DC	Screw terminals, pluggable	R1.188.0460.0	1
	1 s	24 V DC	Screw terminals, pluggable	R1.188.0470.0	1
	2 s	24 V DC	Screw terminals, pluggable	R1.188.0480.0	1
	3 s	24 V DC	Screw terminals, pluggable	R1.188.0490.0	1
SNE 4004KV-C	0.5 s	24 V DC	Push-in terminals, pluggable	R1.188.2410.0	1
	1 s	24 V DC	Push-in terminals, pluggable	R1.188.2420.0	1
	2 s	24 V DC	Push-in terminals, pluggable	R1.188.2430.0	1
	3 s	24 V DC	Push-in terminals, pluggable	R1.188.2440.0	1

TECHNICAL DATA

Function	Emergency stop expansion relay		
Function display	2 LEDs, green		
Function mode / adjustment	Time, fixed		
Adjustment range	0,5 s / 1 s / 2 s / 3 s		
Power supply circuit			
Rated voltage U_N	A1, A2	24 V DC / 24 V AC/DC	
Rated consumption	24 V DC 24 V AC/DC	1.2 W 1.7 W / 3.1 VA	
Rated frequency	50 - 60 Hz		
Operating voltage range U_B	0.85 - 1.1 x U_N		
Electrical isolation supply circuit - control circuit	non		
Control circuit			
Input current / peak current	A1, A2	65 mA / 1800 mA	
Response time t_{A1} / t_{A2}	20 ms		
Minimum ON time t_M	0,15 x t_R		
Recovery time t_W	≤ 200 ms		
Release time t_R	40 ms		
Release time t_{R1} , delayed contacts (tolerance)	0.5 s / 1 s / 2 s / 3 s (± 35 %)		
Max. resistivity, per channel ¹⁾	≤ (2.5 + (1.176 x U_B / U_N - 1) x 50) Ω		
Output circuit			
Enabling paths	13/14, 23/24, 33/34, 43/44	normally open contact	
	17/17, 27/28, 37/38, 47/48	normally open contact, time delayed	
Signaling paths	51/52, 61/62	normally closed contact	
	55/56, 65/66	normally closed contact, time delayed	
Contact assignment	forcebly guided		
Contact type	Ag-alloy, gold-plated		
Rated switching voltage	enabling / signaling path	230 V AC	
	Y1/Y2	230 V AC	
Max. thermal current I_{th}	enabling / signaling path	6 A / 2 A	
	Y1/Y2	2 A	
Max. total current I^2 of all current path	($T_u = 55$ °C)	9 A ²	
Application category (NO)	AC-15 DC-13	U_e 230 V, I_e 5 A U_e 24 V, I_e 5 A	
Short-circuit protection (NO), lead fuse / circuit breaker	6 A class gG / melting integral < 100 A ² s		
Mechanical life	10 ⁷ switching cycles		
General data			
Creepage distances and clearances between the circuits	EN 60664-1		
Protection degree according to EN 60529 (housing / terminals)	IP40 / IP20		
Ambient temperature / storage temperature	-25 °C - +55 °C / -25 °C - + 75 °C		
Wire ranges screw terminals,	fine-stranded / solid	1 x 0.2 mm ² - 2.5 mm ² / 2 x 0.2 mm ² - 1.0 mm ²	
	fine-stranded with ferrules	1 x 0.25 mm ² - 2.5 mm ² / 2 x 0.25 mm ² - 1.0 mm ²	
Permissible torque	0,5 - 0,6 Nm		
Wire ranges push-in terminals	1 x 0.25 mm ² - 1.5 mm ²		
Weight	0.20 kg		
Standards	EN ISO 13849-1, EN 62061		
Approvals	DGUV, cULus, CCC		

¹⁾ If two-channel devices are installed as single channel, the value is halved.

SNE 4012K / SNE 4024K

CONTACT EXPANSION



APPLICATIONS

- Expansion of a basic device's enabling current paths
- Contact expansion in safety equipment
- Up to PL e / Category 4 (EN ISO 13849-1)*
- Up to SIL_{CL} 3 (EN 62061)*

FEATURES

- Stop Category 0 and 1 according to EN 60204-1 (see "Function")
- Single-channel control
- SNE 4012K: 2 enabling current paths (NO contact)
- SNE 4024K: 2x2 enabling current paths (NO contact)

* Depends on the category of the basic device or the safety control.

FUNCTION

Once the supply voltage has been applied to terminals B1/A2 (B2/A2), the enabling current paths (NOC) are automatically closed and the signaling current paths (NCC) are opened.

When the supply voltage is ceased, the enabling current paths (NOC) are immediately opened and the signaling current paths (NCC) are immediately closed.

CIRCUIT DIAGRAMS

SNE 4012K

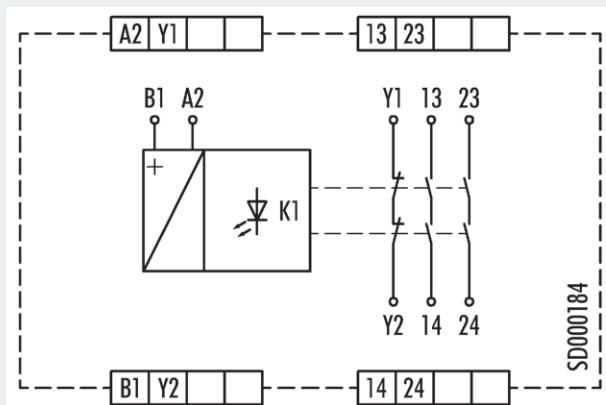

SNE 4024K

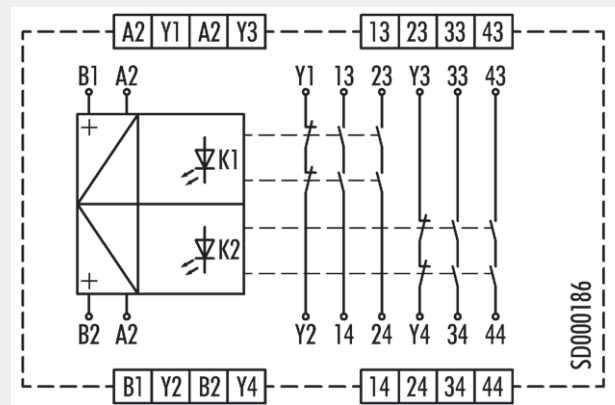

OVERVIEW OF DEVICES | PART NUMBERS

Type	Rated voltage	Terminals	Part no.	P.U.
SNE 4012K-A	24 V DC	Screw terminals, pluggable	R1.188.3910.0	1
SNE 4012K-C	24 V DC	Push-in terminals, pluggable	R1.188.3920.0	1
SNE 4024K-A	24 V DC	Screw terminals, pluggable	R1.188.3930.0	1
SNE 4024K-C	24 V DC	Push-in terminals, pluggable	R1.188.3940.0	1

TECHNICAL DATA				
Function	Emergency stop expansion relay			
Function display – SNE 4012K	1 LED, green			
Function display – SNE 4024K	2 LED, green			
Power supply circuit				
Rated voltage U_N	B1/A2; B2/A2	24 V DC		
Rated consumption – SNE 4012K	0.7 W			
Rated consumption – SNE 4022K	1.4 W			
Operating voltage range U_B	0.75 - 1.25 U_N			
Control circuit				
Input current / peak current	B1/A2	ca. 30 mA / 110 mA		
	B2/A2	ca. 30 mA / 110 mA		
Response time t_{A1} / t_{A2}	< 15 ms			
Recovery time t_W	≤ 30 ms			
Release time t_R	≤ 15 ms			
Max. resistivity, per channel ¹⁾	≤ (5 + (1,333 x U_B / U_N - 1) x 200) Ω			
Output circuit				
Enabling paths	13/14, 23/24	normally open contact		
	33/34, 43/44	normally open contact		
Signaling paths	Y1/Y2	normally closed contact		
	Y3/Y4	normally closed contact		
Contact assignment	forcebly guided			
Contact type	Ag-alloy			
Rated switching voltage	230 V AC, 24 V DC			
Max. thermal current I_{th}	enabling / signaling path	6 A		
Max. total current I^2 of all current path	– SNE 4012K ($T_u = 55^\circ\text{C}$)	72 A ²		
Max. total current I^2 of all current path	– SNE 4024K ($T_u = 55^\circ\text{C}$)	2 x 72 A ² / 2 x 8 A ²		
Application category (NO)	AC-15 DC-13	U_e 230 V, I_e 3 A U_e 24 V, I_e 1 A		
Short-circuit protection (NO), lead fuse / circuit breaker	6 A class gL / melting integral < 100 A ² s			
Mechanical life	10 x 10 ⁶ switching cycles			
General data				
Creepage distances and clearances between the circuits	EN 60664-1			
Protection degree according to EN 60529 (housing / terminals)	IP40 / IP20			
Ambient temperature / storage temperature	-25 °C - +65 °C / -25 °C - + 75 °C			
Wire ranges screw terminals,	fine-stranded / solid	1 x 0.2 mm ² – 2.5 mm ² / 2 x 0.2 mm ² – 1.0 mm ²		
	fine-stranded with ferrules	1 x 0.25 mm ² – 2.5 mm ² / 2 x 0.25 mm ² – 1.0 mm ²		
Permissible torque	0.5 - 0.6 Nm			
Wire ranges push-in terminals	1 x 0.25 mm ² – 1.5 mm ²			
Weight	0.180 kg			
Standards	EN ISO 13849-1, EN 62061, DIN EN 50156-1, EN 61511			
Approvals	TÜV, cULus, CCC			

¹⁾ If two-channel devices are installed as single channel, the value is halved.

SNE 4028S

CONTACT EXPANSION



APPLICATIONS

- Duplication of the enabling current paths of a basic device
- Contact expansion in safety-oriented systems
- Amplification of the output performance of light curtains
- Up to PL e / Category 4 (EN ISO 13849-1)*
- Up to SIL_{CL} 3 (EN 62061)*

FEATURES

- Single-channel or two-channel control
- Cross monitoring
- Safe isolation
- 8 enabling current paths, 1 signal current path

* Depends on the category of the basic device or the safety control.

FUNCTION

After the supply voltage is applied to terminals A1/ A2 and the safety inputs are closed, the enabling current paths (NO contacts) are closed and the signaling current paths (NC contacts) are opened automatically. When the safety inputs are opened/ de-energized the enabling current paths (NO contacts) are opened immediately and the signaling current paths (NC contacts) are closed.

CIRCUIT DIAGRAM

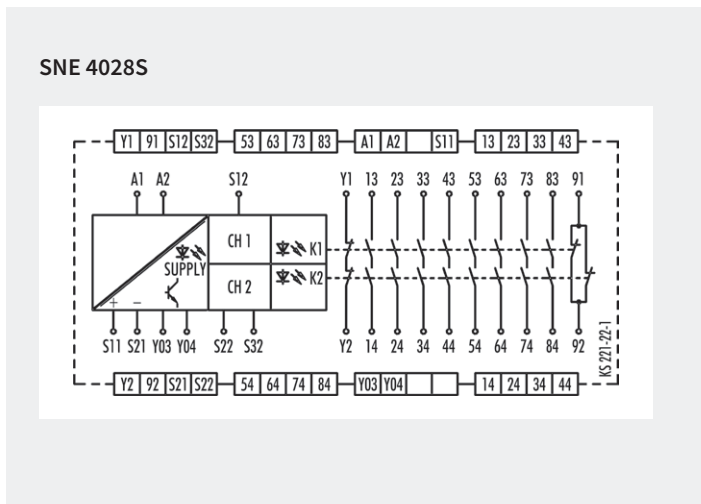



OVERVIEW OF DEVICES | PART NUMBERS

Type	Rated voltage	Terminals	Part no.	P.U.
SNE 4028S-A	24 V DC	Screw terminals, pluggable	R1.188.3120.0	1
SNE 4028S-A	115-230 V AC	Screw terminals, pluggable	R1.188.3510.0	1
SNE 4028S-C	24 V DC	Push-in terminals, pluggable	R1.188.3540.0	1
SNE 4028S-C	115-230 V AC	Push-in terminals, pluggable	R1.188.3550.0	1

TECHNICAL DATA		
Function		Contact expansion relay
Function display		3 LEDs, green
Power supply circuit		
Rated voltage U_N	A1, A2	24 V AC/DC / 115-230 V AC
Rated consumption	24 V AC/DC	3.4 W / 6.1 VA
	115-230 V AC	2.7 W / 6 VA
Rated frequency		50 - 60 Hz
Operating voltage range U_B		0.85 - 1.1 x U_N
Electrical isolation supply circuit - control circuit		yes (at $U_N = 115-230$ V AC)
Control circuit		
Rated output voltage	S11/S21	24 V DC
Input current / peak current	S12, S32/S22	50 mA / 200 mA
Response time t_{A1} / t_{A2}		25 ms
Recovery time t_w		≤ 40 ms
Release time t_R		10 ms
Permissible test pulse time t_{Tp}		< 1 ms
Max. resistivity, per channel ¹⁾	24 V AC/DC	≤ (5 + (1.176 x U_B / U_N - 1) x 100) Ω
	115-230 V AC	≤ 12 Ω
Output circuit		
Enabling paths	13/14, 23/24, 33/34, 43/44	normally open contact
	53/54, 63/64, 73/74, 83/84	normally open contact
Signaling paths	91/92, Y1/Y2	normally closed contact
	Y03/Y04	semiconductor output (PNP), not safety-oriented
Contact assignment		forcebly guided
Contact type		Ag-alloy, gold-plated
Rated switching voltage	enabling- / signaling path	230 V AC / 24 V DC
	Y03/Y04	24 V DC
Max. thermal current I_{th}	enabling- / signaling path	6 A / 2 A
	Y03/Y04	20 mA
Max. total current I_2 of all current path	($T_u = 55$ °C)	2 x 25 A ²
Application category (NO)	AC-15	U_e 230 V, I_e 5 A
	DC-13	U_e 24 V, I_e 5 A
Short-circuit protection (NO), lead fuse / circuit breaker		6 A class gG / melting integral < 90 A ² s
Mechanical life		10 ⁷ switching cycles
General data		
Creepage distances and clearances between the circuits		EN 60664-1
Protection degree according to EN 60529 (housing / terminals)		IP40 / IP20
Ambient temperature / storage temperature		-25 °C - +55 °C / -25 °C - + 75 °C
Wire ranges screw terminals,	fine-stranded / solid	1 x 0.2 mm ² - 2.5 mm ² / 2 x 0.2 mm ² - 1.0 mm ²
	fine-stranded with ferrules	1 x 0.25 mm ² - 2.5 mm ² / 2 x 0.25 mm ² - 1.0 mm ²
Permissible torque		0.5 - 0,6 Nm
Wire ranges push-in terminals		1 x 0.25 mm ² - 1.5 mm ²
Weight		0.38 kg
Standards		EN ISO 13849-1, EN 62061, EN 61511
Approvals		TÜV, cULus, CCC

¹⁾ If two-channel devices are installed as single channel, the value is halved.



SENSOR PRO – SAFE SIGNAL ACQUISITION

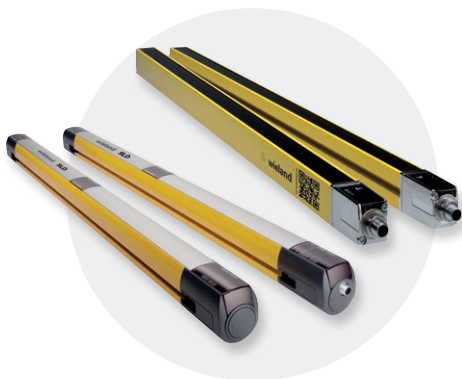

SLC + SLD SERIES

Safety light curtains

SLC series safety light curtains are ideal for realizing optoelectronic protective devices. The SLC series is used to safeguard hazard points, for area protection or access protection.

Safety light curtains

SLD series safety light grids are optoelectronic personal protective devices for access protection at hazard points on plant and machinery.



SENC SERIES

Safe rotary encoders

Safe rotary encoders for functional safety capture information about drive shaft position and angle in the form of increments. They offer users a higher resolution, simpler mounting and a more rugged construction than proximity sensors. Our safe rotary encoders offer redundancy and high diagnostic coverage, which the standard encoders are unable to realize, and hence achieve Kat 4, PL e und SIL 3.



SNH SERIES

Emergency stop buttons

SNH series emergency stop buttons ensure the safety of man and machine, and offer the user a practical, rugged and reliable design.

The quick and simple mounting of the emergency stop buttons saves time and money and the use of the highest-quality materials guarantees a long service life and reliable operation.

SNH series emergency stop buttons are suitable for numerous cross-sectoral applications.





SIN + SMS SERIES

Safety switches with guard control

SIN series safety switches are used for the position monitoring of movable guards and prevent the unintentional opening of safety doors and flaps via the integrated guard control.

Typical fields of application are machines with coasting movements, at which access is allowed to be granted only when the hazard has been eliminated.

Safety switches with separate actuator

SMS series safety switches are used for monitoring movable guards. They are suitable for both personal protection and process protection and available in three different versions.

SLS SERIES

Safe position switches

SLS series switches can be used for safe position monitoring. The switches can be actuated either by plunger or plastic roller.

STS + SMA SERIES

Non-contact safety switches

STS series contactless safety switches offer maximum manipulation protection and are used for the position monitoring of guards.

Magnetic safety switches

SMA series sensors are magnetic safety sensors and are used for contactless safety door and position monitoring. They have integrated manipulation protection and can be used up to IP67.



SERIES SLC

SAFETY LIGHT CURTAIN

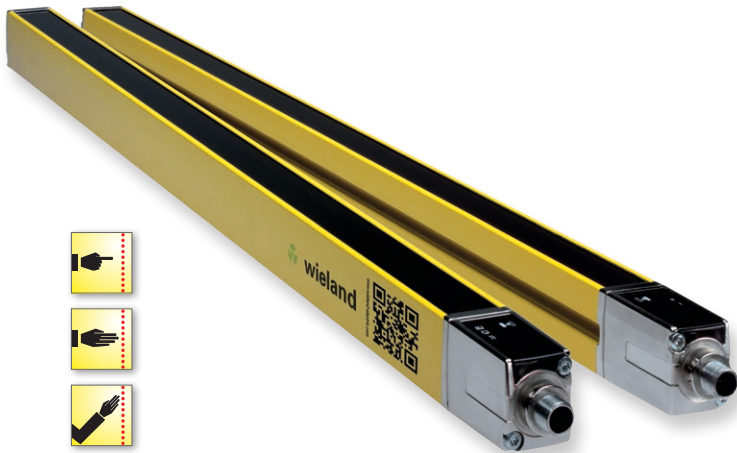

APPLICATIONS

- Access protection (finger, hand and arm protection)
- Access security (personal protection)
- Horizontal zone protection

FEATURES

- Safety light curtain AOPD type 4 or type 2
- Beam resolution 14, 20, 30, 40 and 90 mm
- Protection field heights 150 – 1800 mm
- Extensive accessories



With 3-Zone alignment indication

FUNCTIONS SUITABLE FOR EVERY PROTECTION TASK

All important contactless safety functions on machines and equipment can be realized by means of the three function versions, Standard, Select and Professional of the SLC series.

ADVANTAGES

HIGHER EQUIPMENT AVAILABILITY

- Easy adjustment and stable operation through slim and rigid housing
- Parameterization without PC or DIP switch through simple wiring in the control cabinet
- The integrated Double-Scan technology avoids unwanted shutdown even in harsh operating conditions
- Clear diagnostic and status messages in the 7-segment display ensure shorter downtimes
- Cable lengths up to 100 m with unshielded connection cables ensure greater operational flexibility and reduce costs even under difficult EMC conditions

FASTER DURING COMMISSIONING, OPERATION AND SERVICE

- The 3-zone alignment indicator reduces assembly time and simplifies justage
- The wide range of SLC products permits optimal and cost-effective design of protective devices
- Easy to connect via standard M12 connection technology
- Fast installation and removal on the machine through a system configuration in the control cabinet
- Selectable transmission channels and range reduction prevent mutual interference
- Simplified planning of safeguards because every SLC safety light curtain from 0 m to the maximum range can be implemented



Finger, hand and arm protection on machines with the safety light curtain SLC

SERIES SLC

SAFETY LIGHT CURTAIN



TECHNICAL DATA		
Function	safety light curtain	
Function display	LED	
Power supply circuit		
Rated voltage U_N	24 V DC	
Current consumption (transmitter)	50 mA	
Current consumption, no load (receiver/transceiver)	150 mA	
Operating voltage range U_B	0.8 - 1.2 x U_N	
Electrical isolation supply circuit - control circuit	no	
Protection field data		
	Resolution	Range / protective field height
	14 mm (nur SLC-4)	0 - 6 m / 150 - 1800 mm
	20 mm	0 - 15 m / 150 - 1800 mm
	30 mm	0 - 10 m / 150 - 1800 mm
	40 mm	0 - 20 m / 150 - 1800 mm
	90 mm	0 - 20 m / 600 - 1800 mm
Output circuit OSSD		
Number	2	
Type	Transistor outputs PNP	
Short-circuit monitoring	yes	
Switching current (max., per output)	380 mA	
Leakage current (max.)	200 μ A	
Switching voltage, high active ($U_B - 1V$)	18.0 - 27.0 V	
Switching voltage, low	0 - 2,5 V	
Line resistance / line length	< 200 Ω / \leq 100 m	
Response time	device-dependent	
General data		
Creepage distances and clearances between the circuits	EN 60664-1	
Protection degree according to EN 60529	IP65	
Ambient temperature / storage temperature	-30 °C - +55 °C / -30 °C - + 70 °C	
Connection	M12 (5 pole / 8 pole) device-dependent	
Weight	0.3 - 1.95 kg, device-dependent	
Standards	EN 61496, EN ISO 13849-1, EN 62061	
Approvals	TÜV, c-CSA-us	

sensor PRO

	SLC Standard	SLC Select	SLC Professional
LED display	●	●	●
Range reduction	●	●	●
Selectable transmission channels	●	●	●
7-segment display		●	●
Automatic start	●	●	●
Manual start / restart interlock		●	●
External device monitoring (EDM)		●	
cascading		●	
beam blanking			●
Muting function			●
Device linking			●
variable scan modes			●

SERIES SLC 2 | DEVICE OVERVIEW

SAFETY LIGHT CURTAIN



TRANSMITTER

Protective field height hhhh [mm]	Resolution	20 mm	30 mm	40 mm	90 mm
	Type	SLC-2TR20-hhhh	SLC-2TR30-hhhh	SLC-2TR40-hhhh	SLC-2TR90-hhhh
0150		R1.512.0150.0	R1.513.0150.0	R1.514.0150.0	-
0225		R1.512.0225.0	R1.513.0225.0	R1.514.0225.0	-
0300		R1.512.0300.0	R1.513.0300.0	R1.514.0300.0	-
0450		R1.512.0450.0	R1.513.0450.0	R1.514.0450.0	-
0600		R1.512.0600.0	R1.513.0600.0	R1.514.0600.0	R1.515.0600.0
0750		R1.512.0750.0	R1.513.0750.0	R1.514.0750.0	R1.515.0750.0
0900		R1.512.0900.0	R1.513.0900.0	R1.514.0900.0	R1.515.0900.0
1050		R1.512.1050.0	R1.513.1050.0	R1.514.1050.0	R1.515.1050.0
1200		R1.512.1200.0	R1.513.1200.0	R1.514.1200.0	R1.515.1200.0
1350		R1.512.1350.0	R1.513.1350.0	R1.514.1350.0	R1.515.1350.0
1500		R1.512.1500.0	R1.513.1500.0	R1.514.1500.0	R1.515.1500.0
1650		R1.512.1650.0	R1.513.1650.0	R1.514.1650.0	R1.515.1650.0
1800		R1.512.1800.0	R1.513.1800.0	R1.514.1800.0	R1.515.1800.0

RECEIVER STANDARD

Protective field height hhhh [mm]	Resolution	20 mm	30 mm	40 mm	90 mm
	Type	SLC-2ST20-hhhh	SLC-2ST30-hhhh	SLC-2ST40-hhhh	SLC-2ST90-hhhh
0150		R1.522.0150.0	R1.523.0150.0	R1.524.0150.0	-
0225		R1.522.0225.0	R1.523.0225.0	R1.524.0225.0	-
0300		R1.522.0300.0	R1.523.0300.0	R1.524.0300.0	-
0450		R1.522.0450.0	R1.523.0450.0	R1.524.0450.0	-
0600		R1.522.0600.0	R1.523.0600.0	R1.524.0600.0	R1.525.0600.0
0750		R1.522.0750.0	R1.523.0750.0	R1.524.0750.0	R1.525.0750.0
0900		R1.522.0900.0	R1.523.0900.0	R1.524.0900.0	R1.525.0900.0
1050		R1.522.1050.0	R1.523.1050.0	R1.524.1050.0	R1.525.1050.0
1200		R1.522.1200.0	R1.523.1200.0	R1.524.1200.0	R1.525.1200.0
1350		R1.522.1350.0	R1.523.1350.0	R1.524.1350.0	R1.525.1350.0
1500		R1.522.1500.0	R1.523.1500.0	R1.524.1500.0	R1.525.1500.0
1650		R1.522.1650.0	R1.523.1650.0	R1.524.1650.0	R1.525.1650.0
1800		R1.522.1800.0	R1.523.1800.0	R1.524.1800.0	R1.525.1800.0

RECEIVER SELECT

Protective field height hhhh [mm]	Resolution	20 mm	30 mm	40 mm	90 mm
	Type	SLC-2SL20-hhhh	SLC-2SL30-hhhh	SLC-2SL40-hhhh	SLC-2SL90-hhhh
0150		R1.532.0150.0	R1.533.0150.0	R1.534.0150.0	-
0225		R1.532.0225.0	R1.533.0225.0	R1.534.0225.0	-
0300		R1.532.0300.0	R1.533.0300.0	R1.534.0300.0	-
0450		R1.532.0450.0	R1.533.0450.0	R1.534.0450.0	-
0600		R1.532.0600.0	R1.533.0600.0	R1.534.0600.0	R1.535.0600.0
0750		R1.532.0750.0	R1.533.0750.0	R1.534.0750.0	R1.535.0750.0
0900		R1.532.0900.0	R1.533.0900.0	R1.534.0900.0	R1.535.0900.0
1050		R1.532.1050.0	R1.533.1050.0	R1.534.1050.0	R1.535.1050.0
1200		R1.532.1200.0	R1.533.1200.0	R1.534.1200.0	R1.535.1200.0
1350		R1.532.1350.0	R1.533.1350.0	R1.534.1350.0	R1.535.1350.0
1500		R1.532.1500.0	R1.533.1500.0	R1.534.1500.0	R1.535.1500.0
1650		R1.532.1650.0	R1.533.1650.0	R1.534.1650.0	R1.535.1650.0
1800		R1.532.1800.0	R1.533.1800.0	R1.534.1800.0	R1.535.1800.0

SERIES SLC 4 | DEVICE OVERVIEW

SAFETY LIGHT CURTAIN



TRANSMITTER

Protective field height hhhh [mm]	Resolution	14 mm	20 mm	30 mm	40 mm	90 mm
	Type	SLC-4TR14-hhhh	SLC-4TR20-hhhh	SLC-4TR30-hhhh	SLC-4TR40-hhhh	SLC-4TR90-hhhh
0150		R1.541.0150.0	R1.542.0150.0	R1.543.0150.0	R1.544.0150.0	–
0225		–	R1.542.0225.0	R1.543.0225.0	R1.544.0225.0	–
0300		R1.541.0300.0	R1.542.0300.0	R1.543.0300.0	R1.544.0300.0	–
0450		R1.541.0450.0	R1.542.0450.0	R1.543.0450.0	R1.544.0450.0	–
0600		R1.541.0600.0	R1.542.0600.0	R1.543.0600.0	R1.544.0600.0	R1.545.0600.0
0750		R1.541.0750.0	R1.542.0750.0	R1.543.0750.0	R1.544.0750.0	R1.545.0750.0
0900		R1.541.0900.0	R1.542.0900.0	R1.543.0900.0	R1.544.0900.0	R1.545.0900.0
1050		R1.541.1050.0	R1.542.1050.0	R1.543.1050.0	R1.544.1050.0	R1.545.1050.0
1200		R1.541.1200.0	R1.542.1200.0	R1.543.1200.0	R1.544.1200.0	R1.545.1200.0
1350		R1.541.1350.0	R1.542.1350.0	R1.543.1350.0	R1.544.1350.0	R1.545.1350.0
1500		R1.541.1500.0	R1.542.1500.0	R1.543.1500.0	R1.544.1500.0	R1.545.1500.0
1650		R1.541.1650.0	R1.542.1650.0	R1.543.1650.0	R1.544.1650.0	R1.545.1650.0
1800		R1.541.1800.0	R1.542.1800.0	R1.543.1800.0	R1.544.1800.0	R1.545.1800.0

RECEIVER STANDARD

Protective field height hhhh [mm]	Resolution	14 mm	20 mm	30 mm	40 mm	90 mm
	Type	SLC-4ST14-hhhh	SLC-4ST20-hhhh	SLC-4ST30-hhhh	SLC-4ST40-hhhh	SLC-4ST90-hhhh
0150		R1.551.0150.0	R1.552.0150.0	R1.553.0150.0	R1.554.0150.0	–
0225		–	R1.552.0225.0	R1.553.0225.0	R1.554.0225.0	–
0300		R1.551.0300.0	R1.552.0300.0	R1.553.0300.0	R1.554.0300.0	–
0450		R1.551.0450.0	R1.552.0450.0	R1.553.0450.0	R1.554.0450.0	–
0600		R1.551.0600.0	R1.552.0600.0	R1.553.0600.0	R1.554.0600.0	R1.555.0600.0
0750		R1.551.0750.0	R1.552.0750.0	R1.553.0750.0	R1.554.0750.0	R1.555.0750.0
0900		R1.551.0900.0	R1.552.0900.0	R1.553.0900.0	R1.554.0900.0	R1.555.0900.0
1050		R1.551.1050.0	R1.552.1050.0	R1.553.1050.0	R1.554.1050.0	R1.555.1050.0
1200		R1.551.1200.0	R1.552.1200.0	R1.553.1200.0	R1.554.1200.0	R1.555.1200.0
1350		R1.551.1350.0	R1.552.1350.0	R1.553.1350.0	R1.554.1350.0	R1.555.1350.0
1500		R1.551.1500.0	R1.552.1500.0	R1.553.1500.0	R1.554.1500.0	R1.555.1500.0
1650		R1.551.1650.0	R1.552.1650.0	R1.553.1650.0	R1.554.1650.0	R1.555.1650.0
1800		R1.551.1800.0	R1.552.1800.0	R1.553.1800.0	R1.554.1800.0	R1.555.1800.0

RECEIVER SELECT

Protective field height hhhh [mm]	Resolution	14 mm	20 mm	30 mm	40 mm	90 mm
	Type	SLC-4SL14-hhhh	SLC-4SL20-hhhh	SLC-4SL30-hhhh	SLC-4SL40-hhhh	SLC-4SL90-hhhh
0150		R1.561.0150.0	R1.562.0150.0	R1.563.0150.0	R1.564.0150.0	–
0225		–	R1.562.0225.0	R1.563.0225.0	R1.564.0225.0	–
0300		R1.561.0300.0	R1.562.0300.0	R1.563.0300.0	R1.564.0300.0	–
0450		R1.561.0450.0	R1.562.0450.0	R1.563.0450.0	R1.564.0450.0	–
0600		R1.561.0600.0	R1.562.0600.0	R1.563.0600.0	R1.564.0600.0	R1.565.0600.0
0750		R1.561.0750.0	R1.562.0750.0	R1.563.0750.0	R1.564.0750.0	R1.565.0750.0
0900		R1.561.0900.0	R1.562.0900.0	R1.563.0900.0	R1.564.0900.0	R1.565.0900.0
1050		R1.561.1050.0	R1.562.1050.0	R1.563.1050.0	R1.564.1050.0	R1.565.1050.0
1200		R1.561.1200.0	R1.562.1200.0	R1.563.1200.0	R1.564.1200.0	R1.565.1200.0
1350		R1.561.1350.0	R1.562.1350.0	R1.563.1350.0	R1.564.1350.0	R1.565.1350.0
1500		R1.561.1500.0	R1.562.1500.0	R1.563.1500.0	R1.564.1500.0	R1.565.1500.0
1650		R1.561.1650.0	R1.562.1650.0	R1.563.1650.0	R1.564.1650.0	R1.565.1650.0
1800		R1.561.1800.0	R1.562.1800.0	R1.563.1800.0	R1.564.1800.0	R1.565.1800.0

sensor PRO

SERIES SLC 4 | DEVICE OVERVIEW



SAFETY LIGHT CURTAIN

RECEIVER PROFESSIONAL

Protective field height hhhh [mm]	Resolution	14 mm	20 mm	30 mm	40 mm	90 mm
	Type	SLC-4PR14-hhhh	SLC-4PR20-hhhh	SLC-4PR30-hhhh	SLC-4PR40-hhhh	SLC-4PR90-hhhh
0150		R1.571.0150.0	R1.572.0150.0	R1.573.0150.0	R1.574.0150.0	–
0225		–	R1.572.0225.0	R1.573.0225.0	R1.574.0225.0	–
0300		R1.571.0300.0	R1.572.0300.0	R1.573.0300.0	R1.574.0300.0	–
0450		R1.571.0450.0	R1.572.0450.0	R1.573.0450.0	R1.574.0450.0	R1.575.0450.0
0600		R1.571.0600.0	R1.572.0600.0	R1.573.0600.0	R1.574.0600.0	R1.575.0600.0
0750		R1.571.0750.0	R1.572.0750.0	R1.573.0750.0	R1.574.0750.0	R1.575.0750.0
0900		R1.571.0900.0	R1.572.0900.0	R1.573.0900.0	R1.574.0900.0	R1.575.0900.0
1050		R1.571.1050.0	R1.572.1050.0	R1.573.1050.0	R1.574.1050.0	R1.575.1050.0
1200		R1.571.1200.0	R1.572.1200.0	R1.573.1200.0	R1.574.1200.0	R1.575.1200.0
1350		R1.571.1350.0	R1.572.1350.0	R1.573.1350.0	R1.574.1350.0	R1.575.1350.0
1500		R1.571.1500.0	R1.572.1500.0	R1.573.1500.0	R1.574.1500.0	R1.575.1500.0
1650		R1.571.1650.0	R1.572.1650.0	R1.573.1650.0	R1.574.1650.0	R1.575.1650.0
1800		R1.571.1800.0	R1.572.1800.0	R1.573.1800.0	R1.574.1800.0	R1.575.1800.0

TRANSMITTER, HOST

Protective field height hhhh [mm]	Resolution	14 mm	20 mm	30 mm	40 mm	90 mm
	Type	SLC-4TR14-hhhhH	SLC-4TR20-hhhhH	SLC-4TR30-hhhhH	SLC-4TR40-hhhhH	SLC-4TR90-hhhhH
0225		–	R1.542.0225.1	–	–	–
0300		R1.541.0300.1	R1.542.0300.1	R1.543.0300.1	R1.544.0300.1	–
0450		R1.541.0450.1	R1.542.0450.1	R1.543.0450.1	R1.544.0450.1	R1.545.0450.1
0600		R1.541.0600.1	R1.542.0600.1	R1.543.0600.1	R1.544.0600.1	R1.545.0600.1
0750		R1.541.0750.1	R1.542.0750.1	R1.543.0750.1	R1.544.0750.1	R1.545.0750.1
0900		R1.541.0900.1	R1.542.0900.1	R1.543.0900.1	R1.544.0900.1	R1.545.0900.1
1050		R1.541.1050.1	R1.542.1050.1	R1.543.1050.1	R1.544.1050.1	R1.545.1050.1
1200		R1.541.1200.1	R1.542.1200.1	R1.543.1200.1	R1.544.1200.1	R1.545.1200.1
1350		R1.541.1350.1	R1.542.1350.1	R1.543.1350.1	R1.544.1350.1	R1.545.1350.1
1500		R1.541.1500.1	R1.542.1500.1	R1.543.1500.1	R1.544.1500.1	R1.545.1500.1
1650		R1.541.1650.1	R1.542.1650.1	R1.543.1650.1	R1.544.1650.1	R1.545.1650.1
1800		R1.541.1800.1	R1.542.1800.1	R1.543.1800.1	R1.544.1800.1	R1.545.1800.1

RECEIVER SELECT, HOST

Protective field height hhhh [mm]	Resolution	14 mm	20 mm	30 mm	40 mm	90 mm
	Type	SLC-4SL14-hhhhH	SLC-4SL20-hhhhH	SLC-4SL30-hhhhH	SLC-4SL40-hhhhH	SLC-4SL90-hhhhH
0225		–	R1.562.0225.1	–	–	–
0300		R1.561.0300.1	R1.562.0300.1	R1.563.0300.1	R1.564.0300.1	–
0450		R1.561.0450.1	R1.562.0450.1	R1.563.0450.1	R1.564.0450.1	R1.565.0450.1
0600		R1.561.0600.1	R1.562.0600.1	R1.563.0600.1	R1.564.0600.1	R1.565.0600.1
0750		R1.561.0750.1	R1.562.0750.1	R1.563.0750.1	R1.564.0750.1	R1.565.0750.1
0900		R1.561.0900.1	R1.562.0900.1	R1.563.0900.1	R1.564.0900.1	R1.565.0900.1
1050		R1.561.1050.1	R1.562.1050.1	R1.563.1050.1	R1.564.1050.1	R1.565.1050.1
1200		R1.561.1200.1	R1.562.1200.1	R1.563.1200.1	R1.564.1200.1	R1.565.1200.1
1350		R1.561.1350.1	R1.562.1350.1	R1.563.1350.1	R1.564.1350.1	R1.565.1350.1
1500		R1.561.1500.1	R1.562.1500.1	R1.563.1500.1	R1.564.1500.1	R1.565.1500.1
1650		R1.561.1650.1	R1.562.1650.1	R1.563.1650.1	R1.564.1650.1	R1.565.1650.1
1800		R1.561.1800.1	R1.562.1800.1	R1.563.1800.1	R1.564.1800.1	R1.565.1800.1

TRANSMITTER, GUEST



Protective field height hhhh [mm]	Resolution	14 mm	20 mm	30 mm	40 mm	90 mm
	Type	SLC-4TR14-hhhhG	SLC-4TR20-hhhhG	SLC-4TR30-hhhhG	SLC-4TR40-hhhhG	SLC-4TR90-hhhhG
0150		R1.541.0150.2	R1.542.0150.2	-		-
0225		-	R1.542.0225.2	-		-
0300		R1.541.0300.2	R1.542.0300.2	R1.543.0300.2	R1.544.0300.2	-
0450		R1.541.0450.2	R1.542.0450.2	R1.543.0450.2	R1.544.0450.2	R1.545.0450.2
0600		R1.541.0600.2	R1.542.0600.2	R1.543.0600.2	R1.544.0600.2	R1.545.0600.2
0750		R1.541.0750.2	R1.542.0750.2	R1.543.0750.2	R1.544.0750.2	R1.545.0750.2
0900		R1.541.0900.2	R1.542.0900.2	R1.543.0900.2	R1.544.0900.2	R1.545.0900.2
1050		R1.541.1050.2	R1.542.1050.2	R1.543.1050.2	R1.544.1050.2	R1.545.1050.2
1200		R1.541.1200.2	R1.542.1200.2	R1.543.1200.2	R1.544.1200.2	R1.545.1200.2
1350		R1.541.1350.2	R1.542.1350.2	R1.543.1350.2	R1.544.1350.2	R1.545.1350.2
1500		R1.541.1500.2	R1.542.1500.2	R1.543.1500.2	R1.544.1500.2	R1.545.1500.2
1650		R1.541.1650.2	R1.542.1650.2	R1.543.1650.2	R1.544.1650.2	R1.545.1650.2
1800		R1.541.1800.2	R1.542.1800.2	R1.543.1800.2	R1.544.1800.2	R1.545.1800.2

RECEIVER SELECT, GUEST

Protective field height hhhh [mm]	Resolution	14 mm	20 mm	30 mm	40 mm	90 mm
	Type	SLC-4SL14-hhhhG	SLC-4SL20-hhhhG	SLC-4SL30-hhhhG	SLC-4SL40-hhhhG	SLC-4SL90-hhhhG
0150		R1.561.0150.2	R1.562.0150.2	-	-	-
0225		-	R1.562.0225.2	-	-	-
0300		R1.561.0300.2	R1.562.0300.2	R1.563.0300.2	R1.564.0300.2	-
0450		R1.561.0450.2	R1.562.0450.2	R1.563.0450.2	R1.564.0450.2	R1.565.0450.2
0600		R1.561.0600.2	R1.562.0600.2	R1.563.0600.2	R1.564.0600.2	R1.565.0600.2
0750		R1.561.0750.2	R1.562.0750.2	R1.563.0750.2	R1.564.0750.2	R1.565.0750.2
0900		R1.561.0900.2	R1.562.0900.2	R1.563.0900.2	R1.564.0900.2	R1.565.0900.2
1050		R1.561.1050.2	R1.562.1050.2	R1.563.1050.2	R1.564.1050.2	R1.565.1050.2
1200		R1.561.1200.2	R1.562.1200.2	R1.563.1200.2	R1.564.1200.2	R1.565.1200.2
1350		R1.561.1350.2	R1.562.1350.2	R1.563.1350.2	R1.564.1350.2	R1.565.1350.2
1500		R1.561.1500.2	R1.562.1500.2	R1.563.1500.2	R1.564.1500.2	R1.565.1500.2
1650		R1.561.1650.2	R1.562.1650.2	R1.563.1650.2	R1.564.1650.2	R1.565.1650.2
1800		R1.561.1800.2	R1.562.1800.2	R1.563.1800.2	R1.564.1800.2	R1.565.1800.2

TRANSMITTER, MIDDLE-GUEST

Protective field height hhhh [mm]	Resolution	14 mm	20 mm	30 mm	40 mm	90 mm
	Type	SLC-4TR14-hhhhM	SLC-4TR20-hhhhM	SLC-4TR30-hhhhM	SLC-4TR40-hhhhM	SLC-4TR90-hhhhM
0150		R1.541.0150.3	R1.542.0150.3	-	-	-
0225		-	R1.542.0225.3	-	-	-
0300		R1.541.0300.3	R1.542.0300.3	R1.543.0300.3	R1.544.0300.3	-
0450		R1.541.0450.3	R1.542.0450.3	R1.543.0450.3	R1.544.0450.3	R1.545.0450.3
0600		R1.541.0600.3	R1.542.0600.3	R1.543.0600.3	R1.544.0600.3	R1.545.0600.3
0750		R1.541.0750.3	R1.542.0750.3	R1.543.0750.3	R1.544.0750.3	R1.545.0750.3
0900		R1.541.0900.3	R1.542.0900.3	R1.543.0900.3	R1.544.0900.3	R1.545.0900.3
1050		R1.541.1050.3	R1.542.1050.3	R1.543.1050.3	R1.544.1050.3	R1.545.1050.3
1200		R1.541.1200.3	R1.542.1200.3	R1.543.1200.3	R1.544.1200.3	R1.545.1200.3
1350		R1.541.1350.3	R1.542.1350.3	R1.543.1350.3	R1.544.1350.3	R1.545.1350.3
1500		R1.541.1500.3	R1.542.1500.3	R1.543.1500.3	R1.544.1500.3	R1.545.1500.3
1650		R1.541.1650.3	R1.542.1650.3	R1.543.1650.3	R1.544.1650.3	R1.545.1650.3
1800		R1.541.1800.3	R1.542.1800.3	R1.543.1800.3	R1.544.1800.3	R1.545.1800.3

RECEIVER SELECT, MIDDLE-GUEST

Protective field height hhhh [mm]	Resolution	14 mm	20 mm	30 mm	40 mm	90 mm
	Type	SLC-4SL14-hhhhM	SLC-4SL20-hhhhM	SLC-4SL30-hhhhM	SLC-4SL40-hhhhM	SLC-4SL90-hhhhM
0150		R1.561.0150.3	R1.562.0150.3	-	-	-
0225		-	R1.562.0225.3	-	-	-
0300		R1.561.0300.3	R1.562.0300.3	R1.563.0300.3	R1.564.0300.3	-
0450		R1.561.0450.3	R1.562.0450.3	R1.563.0450.3	R1.564.0450.3	R1.565.0450.3
0600		R1.561.0600.3	R1.562.0600.3	R1.563.0600.3	R1.564.0600.3	R1.565.0600.3
0750		R1.561.0750.3	R1.562.0750.3	R1.563.0750.3	R1.564.0750.3	R1.565.0750.3
0900		R1.561.0900.3	R1.562.0900.3	R1.563.0900.3	R1.564.0900.3	R1.565.0900.3
1050		R1.561.1050.3	R1.562.1050.3	R1.563.1050.3	R1.564.1050.3	R1.565.1050.3
1200		R1.561.1200.3	R1.562.1200.3	R1.563.1200.3	R1.564.1200.3	R1.565.1200.3
1350		R1.561.1350.3	R1.562.1350.3	R1.563.1350.3	R1.564.1350.3	R1.565.1350.3
1500		R1.561.1500.3	R1.562.1500.3	R1.563.1500.3	R1.564.1500.3	R1.565.1500.3
1650		R1.561.1650.3	R1.562.1650.3	R1.563.1650.3	R1.564.1650.3	R1.565.1650.3
1800		R1.561.1800.3	R1.562.1800.3	R1.563.1800.3	R1.564.1800.3	R1.565.1800.3

sensor PRO



SERIES SLD

SAFETY LIGHT GRID



PERSONAL PROTECTION FUNCTION

The SLD safety light grids are especially suitable for the contactless safeguarding of hazardous areas and for personal protection on machines and equipment.

ADVANTAGES

FASTER DURING COMMISSIONING, OPERATION AND SERVICE

- The integrated laser alignment aid (optional) permits precise mounting and reduces the startup times of the SLD system
- Parameterization without PC or DIP switch through simple wiring in the control cabinet
- Robust device columns with spring-loaded base mounting and integrated alignment aid are available for the free-standing implementation

APPLICATIONS

- Access security (personal protection)
- Safeguarding of hazardous areas

FEATURES

- Safety light grid AOPD type 4
- 1-, 2-, 3- and 4-beam resolutions
- Also available as an universal system, i.e. transmitter/receiver in a single unit
- High ranges up to 100 m can be implemented
- Extensive accessories

Integrated laser alignment aid



INCREASED RELIABILITY

- Robust aluminum housing in IP67
- Operating temperature range -30 °C to 55 °C permits implementation even in the harshest environments
- Multi-beam scanning avoids unwanted shutdown
- Mutual interference is avoided through the adjustable range reduction when implementing multiple systems

SERIES SLD

SAFETY LIGHT GRID

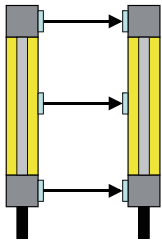

SLD STANDARD / SLD SELECT / SLD PROFESSIONAL

The safety light grid SLD Standard, SLD Select and SLD Professional each consist of a transmitter and a receiver unit and are thus suitable for highest ranges

- 1-, 2-, 3- and 4-beam systems
- Ranges up to 100 m

	SLD Standard	SLD Select	SLD Professional
LED display	●	●	●
Multi-scan technology	●	●	●
Range reduction	●	●	●
Laser alignment aid (optional)	●	●	●
Automatic start	●	●	
Manual start / restart interlock		●	●
External device monitoring (EDM)		●	●
7-segment display			●
Muting function (optional)			●
Muting lamp integrated (optional)			●

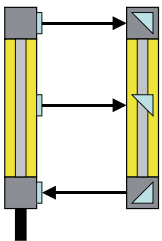

SLD UNIVERSAL – LESS CABLING EXPENDITURE

The safety light grids consist of an integrated SLD universal transmitter/receiver unit and a passive reflector unit without electrical connection.

- 2- and 3-beam systems
- Range up to 8 m

	SLD Universal Standard	SLD Universal Select	SLD Universal Professional
Transceiver system	●	●	●
LED display	●	●	●
Multi-scan technology	●	●	●
Automatic start	●	●	
Manual start / restart interlock		●	●
External device monitoring (EDM)		●	●
7-segment display			●
Muting function			●
Muting lamp integrated			●

SERIES SLD

SAFETY LIGHT GRID



TECHNICAL DATA		
Function	safety light grid	
Function display	LED	
Power supply circuit		
Rated voltage U_N	24 V DC	
Current consumption (transmitter)	50 mA	
Current consumption, no load (receiver/transceiver)	150 mA	
Operating voltage range U_B	0.8 - 1.2 x U_N	
Electrical isolation supply circuit - control circuit	no	
Protection field data		
	Beams	Range
	2	0.5 - 50 m / 20 - 70 m / 0.5 - 8 m
	3	0.5 - 50 m / 20 - 70 m / 0.5 - 6 m
	4	0.5 - 50 m / 20 - 70 m
Output circuit OSSD		
Number	2	
Type	Transistor outputs PNP	
Short-circuit monitoring	ja	
Switching current (max., per output)	380 mA	
Leakage current (max.)	200 μ A	
Switching voltage, high active ($U_B - 1V$)	18.0 - 27.8 V	
Switching voltage, low	0 - 2,5 V	
Line resistance / line length	< 200 Ω	
Response time	25 ms	
General data		
Creepage distances and clearances between the circuits	EN 60664-1	
Protection degree according to EN 60529	IP67	
Ambient temperature / storage temperature	-30 °C - +55 °C / -40 °C - + 75 °C	
Connection	M12 (5 pole / 8 pole) device-dependent	
Weight	1.4 - 2.2 kg, device-dependent	
Standards	EN 61496, EN ISO 13849-1, EN 62061	
Approvals	TÜV, c-CSA-us	

Note: For the connection of safety light grids SLD shielded cables are mandatory.



← Integrated muting and status indicator light

INTEGRATED MUTING – DECENTRALIZED SECURITY FUNCTION ON-BOARD

- Optional time- or sequence-controlled 2-sensor-muting
- Partial muting (the highest light beam stays active)
- Integrated muting/status indicator light

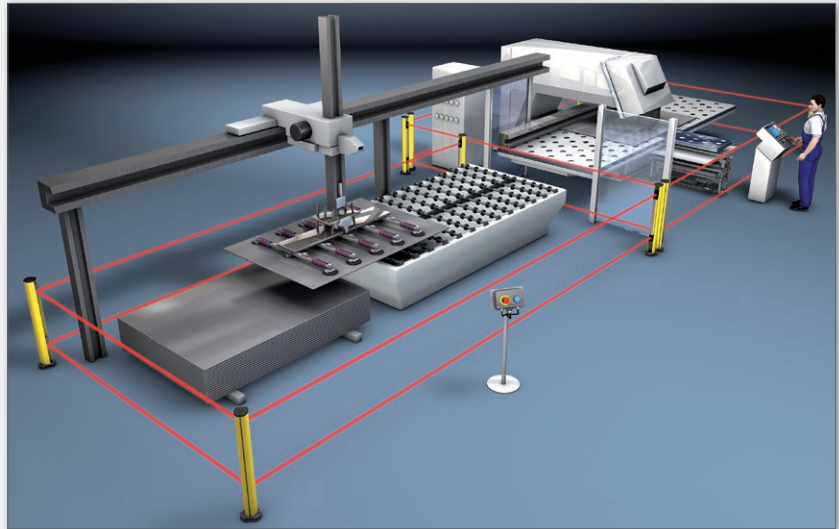

Multi-sided safeguarding of a sheet metal processing machine by SLD safety light grids and SLD deflection mirrors.

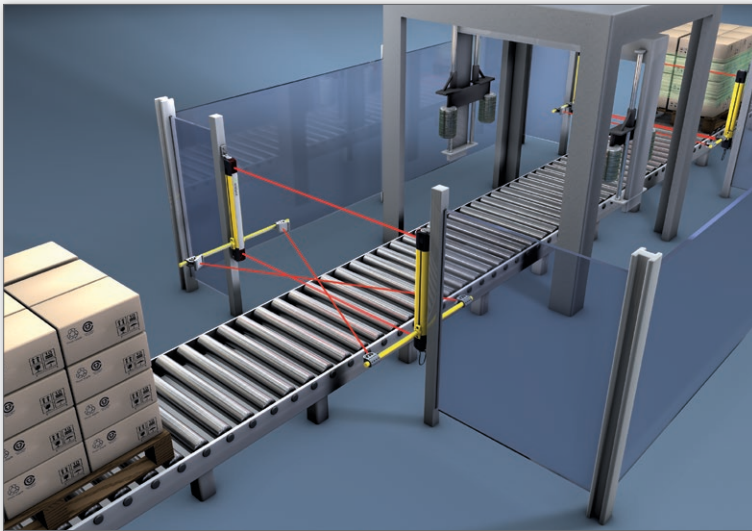

Safety light grids SLD Professional with time-controlled 2-sensor-muting at a packaging machine.

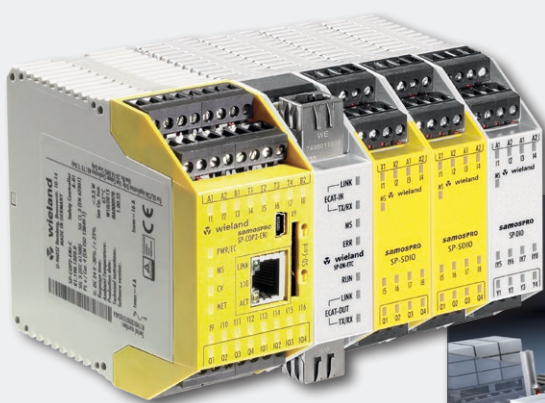

SLD – MUTING FUNCTIONS WITH SAMOS[®]PRO

SLD safety light grids are ideally suited for monitoring material locks, such as in the packaging industry, in combination with the freely configurable muting function blocks of samos[®]PRO, for example in the packaging industry.

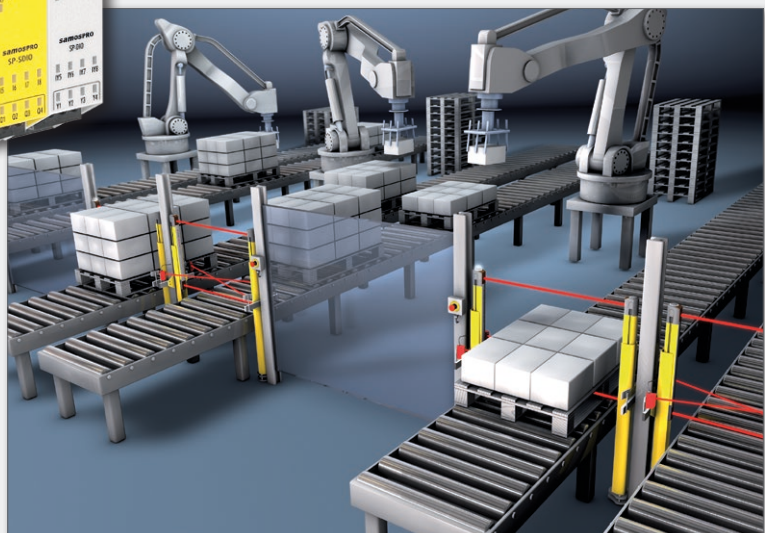

SERIES SLD | DEVICE OVERVIEW

SAFETY LIGHT GRIDS



TRANSMITTER

Type	Description	Part. no.	P.U.
SLD-4TR1-0-70	Transmitter, 1 beam, range 70 m	R1.641.1050.0	1
SLD-4TR1-1-70	Transmitter, 1 beam, range 70 m, laser alignment aid	R1.641.1150.0	1
SLD-4TR1-0-00	Transmitter, 1 beam, range 100 m	R1.641.1070.0	1
SLD-4TR2-0-50	Transmitter, 2 beams, range 50 m	R1.641.2050.0	1
SLD-4TR2-0-70	Transmitter, 2 beams, range 70 m	R1.641.2070.0	1
SLD-4TR2-1-50	Transmitter, 2 beams, range 50 m, laser alignment aid	R1.641.2150.0	1
SLD-4TR2-1-70	Transmitter, 2 beams, range 70 m, laser alignment aid	R1.641.2170.0	1
SLD-4TR3-0-50	Transmitter, 3 beams, range 50 m	R1.641.3050.0	1
SLD-4TR3-0-70	Transmitter, 3 beams, range 70 m	R1.641.3070.0	1
SLD-4TR3-1-50	Transmitter, 3 beams, range 50 m, laser alignment aid	R1.641.3150.0	1
SLD-4TR3-1-70	Transmitter, 3 beams, range 70 m, laser alignment aid	R1.641.3170.0	1
SLD-4TR4-0-50	Transmitter, 4 beams, range 50 m	R1.641.4050.0	1
SLD-4TR4-0-70	Transmitter, 4 beams, range 70 m	R1.641.4070.0	1
SLD-4TR4-1-50	Transmitter, 4 beams, range 50 m, laser alignment aid	R1.641.4150.0	1
SLD-4TR4-1-70	Transmitter, 4 beams, range 70 m, laser alignment aid	R1.641.4170.0	1

RECEIVER STANDARD

Type	Description	Part. no.	P.U.
SLD-4ST1-0-70	Receiver-Standard, 1 beam, range 70 m	R1.642.1050.0	1
SLD-4ST1-1-70	Receiver-Standard, 1 beam, range 70 m, laser alignment aid	R1.642.1150.0	1
SLD-4ST1-0-00	Receiver-Standard, 1 beam, range 100 m	R1.642.1070.0	1
SLD-4ST2-0-50	Receiver-Standard, 2 beams, range 50 m	R1.642.2050.0	1
SLD-4ST2-0-70	Receiver-Standard, 2 beams, range 70 m	R1.642.2070.0	1
SLD-4ST2-1-50	Receiver-Standard, 2 beams, range 50 m, laser alignment aid	R1.642.2150.0	1
SLD-4ST2-1-70	Receiver-Standard, 2 beams, range 70 m, laser alignment aid	R1.642.2170.0	1
SLD-4ST3-0-50	Receiver-Standard, 3 beams, range 50 m	R1.642.3050.0	1
SLD-4ST3-0-70	Receiver-Standard, 3 beams, range 70 m	R1.642.3070.0	1
SLD-4ST3-1-50	Receiver-Standard, 3 beams, range 50 m, laser alignment aid	R1.642.3150.0	1
SLD-4ST3-1-70	Receiver-Standard, 3 beams, range 70 m, laser alignment aid	R1.642.3170.0	1
SLD-4ST4-0-50	Receiver-Standard, 4 beams, range 50 m	R1.642.4050.0	1
SLD-4ST4-0-70	Receiver-Standard, 4 beams, range 70 m	R1.642.4070.0	1
SLD-4ST4-1-50	Receiver-Standard, 4 beams, range 50 m, laser alignment aid	R1.642.4150.0	1
SLD-4ST4-1-70	Receiver-Standard, 4 beams, range 70 m, laser alignment aid	R1.642.4170.0	1

RECEIVER SELECT

Type	Description	Part. no.	P.U.
SLD-4SL1-0-70	Receiver-Select, 1 beam, range 70 m	R1.643.1050.0	1
SLD-4SL1-1-70	Receiver-Select, 1 beam, range 70 m, laser alignment aid	R1.643.1150.0	1
SLD-4SL1-0-00	Receiver-Select, 1 beam, range 100 m	R1.643.1070.0	1
SLD-4SL2-0-50	Receiver-Select, 2 beams, range 50 m	R1.643.2050.0	1
SLD-4SL2-0-70	Receiver-Select, 2 beams, range 70 m	R1.643.2070.0	1
SLD-4SL2-1-50	Receiver-Select, 2 beams, range 50 m, laser alignment aid	R1.643.2150.0	1
SLD-4SL2-1-70	Receiver-Select, 2 beams, range 70 m, laser alignment aid	R1.643.2170.0	1
SLD-4SL3-0-50	Receiver-Select, 3 beams, range 50 m	R1.643.3050.0	1
SLD-4SL3-0-70	Receiver-Select, 3 beams, range 70 m	R1.643.3070.0	1
SLD-4SL3-1-50	Receiver-Select, 3 beams, range 50 m, laser alignment aid	R1.643.3150.0	1
SLD-4SL3-1-70	Receiver-Select, 3 beams, range 70 m, laser alignment aid	R1.643.3170.0	1
SLD-4SL4-0-50	Receiver-Select, 4 beams, range 50 m	R1.643.4050.0	1
SLD-4SL4-0-70	Receiver-Select, 4 beams, range 70 m	R1.643.4070.0	1
SLD-4SL4-1-50	Receiver-Select, 4 beams, range 50 m, laser alignment aid	R1.643.4150.0	1
SLD-4SL4-1-70	Receiver-Select, 4 beams, range 70 m, laser alignment aid	R1.643.4170.0	1



RECEIVER PROFESSIONAL

Type	Description	Part. no.	P.U.
SLD-4PR1-0-70	Receiver Professional, 1 beam, range 70 m	R1.647.1050.0	1
SLD-4PR2-0-50	Receiver Professional, 2 beams, range 50 m	R1.647.2050.0	1
SLD-4PR3-0-50	Receiver Professional, 3 beams, range 50 m	R1.647.3050.0	1
SLD-4PR4-0-50	Receiver Professional, 4 beams, range 50 m	R1.647.4050.0	1
SLD-4PR1-0-00	Receiver Professional, 1 beam, range 100 m	R1.647.1070.0	1
SLD-4PR2-0-70	Receiver Professional, 2 beams, range 70 m	R1.647.2070.0	1
SLD-4PR3-0-70	Receiver Professional, 3 beams, range 70 m	R1.647.3070.0	1
SLD-4PR4-0-70	Receiver Professional, 4 beams, range 70 m	R1.647.4070.0	1
SLD-4PR1-1-70	Receiver Professional, 1 beam, range 70 m, laser alignment aid	R1.647.1150.0	1
SLD-4PR2-1-50	Receiver Professional, 2 beams, range 50 m, laser alignment aid	R1.647.2150.0	1
SLD-4PR3-1-50	Receiver Professional, 3 beams, range 50 m, laser alignment aid	R1.647.3150.0	1
SLD-4PR4-1-50	Receiver Professional, 4 beams, range 50 m, laser alignment aid	R1.647.4150.0	1
SLD-4PR2-1-70	Receiver Professional, 2 beams, range 70 m, laser alignment aid	R1.647.2170.0	1
SLD-4PR3-1-70	Receiver Professional, 3 beams, range 70 m, laser alignment aid	R1.647.3170.0	1
SLD-4PR4-1-70	Receiver Professional, 4 beams, range 70 m, laser alignment aid	R1.647.4170.0	1
SLD-4PR2-2-50	Receiver Professional, 2 beams, range 50 m, muting lamp	R1.647.2250.0	1
SLD-4PR3-2-50	Receiver Professional, 3 beams, range 50 m, muting lamp	R1.647.3250.0	1
SLD-4PR4-2-50	Receiver Professional, 4 beams, range 50 m, muting lamp	R1.647.4250.0	1
SLD-4PR2-3-50	Receiver Professional, 2 beams, range 50 m, muting lamp, laser alignment aid	R1.647.2350.0	1
SLD-4PR3-3-50	Receiver Professional, 3 beams, range 50 m, muting lamp, laser alignment aid	R1.647.3350.0	1
SLD-4PR4-3-50	Receiver Professional, 4 beams, range 50 m, muting lamp, laser alignment aid	R1.647.4350.0	1

UNIVERSAL

Type	Description	Part. no.	P.U.
SLD-4US2-0-00	Universal-Standard, 2 beams	R1.644.2000.0	1
SLD-4US3-0-00	Universal-Standard, 3 beams	R1.644.3000.0	1
SLD-4UL2-0-00	Universal-Select, 2 beams	R1.645.2000.0	1
SLD-4UL3-0-00	Universal-Select, 3 beams	R1.645.3000.0	1
SLD-4UP2-0-00	Universal-Professional, 2 beams	R1.648.2000.0	1
SLD-4UP3-0-00	Universal-Professional, 3 beams	R1.648.3000.0	1
SLD-4UP2-2-00	Universal-Professional, 2 beams, muting lamp	R1.648.2200.0	1
SLD-4UP3-2-00	Universal-Professional, 3 beams, muting lamp	R1.648.3200.0	1
SLD-MIR2-0-08	Mirror, 2 beams, range 8 m	R1.606.2008.0	1
SLD-MIR3-0-06	Mirror, 3 beams, range 6 m	R1.606.3006.0	1
SLD-MIR3-0-08	Mirror, 3 beams, range 8 m	R1.606.3008.0	1



SERIES SLC

MOUNTING ACCESSORIES

The swivel mount set **SLX-MO-RO2** is used for wall mounting of series SLC (360° horizontal adjustment possible).

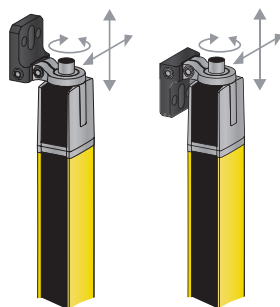

SERIES SLD

MOUNTING ACCESSORIES

The swivel mount set **SLX-MO-RO-SET1** (**SLX-MO-RO-SET1S** with shock absorber) is used for wall mounting of Transmitter, Receiver and Transceiver from series SLD (240° horizontal adjustment possible).

The swivel mount set **SLX-MO-RO-SET2** (**SLX-MO-RO-SET2S** with shock absorber) is used for wall mounting of Mirror from series SLD (240° horizontal adjustment possible).

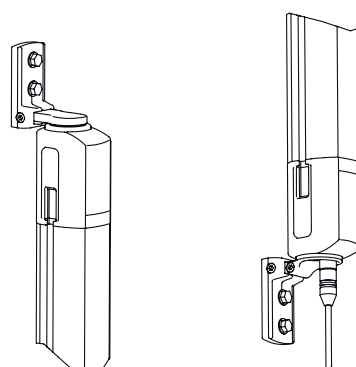

OVERVIEW OF DEVICES | PART NUMBERS

Type	Description	Part no.	P.U.
SLX-MO-RO2	Rotative bracket 360°, 2 pcs., inkl. 1 pcs. SLC cylinder	R1.591.0020.0	1
SLX-MO-RO2S	Rotative bracket 360°, vibration damped, 2 pcs., inkl. 1 pcs. SLC cylinder	R1.591.0021.0	1
SLX-MO-RO-SET1	Set with SLX-MO-RO-B + SLX-MO-RO-C + screws	R1.591.0011.0	1
SLX-MO-RO-SET2	Set with 2 x SLX-MO-RO-C + screws	R1.591.0012.0	1
SLX-MO-RO-SET1-S	Set with SLX-MO-RO-B, SLX-MO-RO-C + screws + shockabsorber	R1.591.0013.0	1
SLX-MO-RO-SET2-S	Set with 2 x SLX-MO-RO-C + screws + shockabsorber	R1.591.0014.0	1



SERIES SLC / SLD

MOUNTING ACCESSORIES



SLX-MO-L



SLX-MO-Z



SLX-MO-TNUT

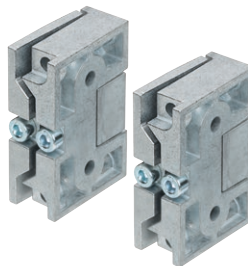

SLX-MO-2RO3



SLX-MO-2RO3S

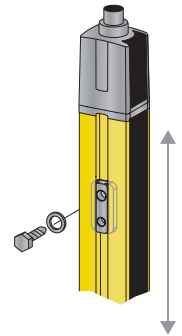

SLX-MO-RO270-S

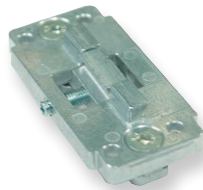

SLX-MO-CLIP

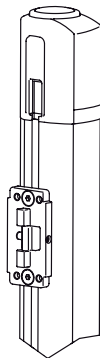

The **SLX-MO-TNUT** sets including sliding blocks for mounting of series SLC/SLD.

The **SLX-MO-L** and **SLX-MO-Z** sets are used for wall mounting of series SLC/SLD in combination with sliding blocks SLX-MO-TNUT.

The new swiveling mounting brackets **SLX-MO-2RO3** (**SLX-MO-2RO3S** with shock absorber) are used for adjustable wall mounting.

The **SLX-MO-CLIP** is used for fixed mounting of series SLC/SLD in device columns SLX-COL.

The swiveling mounting brackets **SLX-MO-RO-S** and **SLX-MO-RO270-S** are used for mounting series SLC/SLD in device columns SLX-COL. These brackets are adjustable and with vibration damping.

OVERVIEW OF DEVICES | PART NUMBERS

Type	Description	Part no.	P.U.
SLX-MO-L	L-Bracket, 2 pcs.	R1.591.0004.0	1
SLX-MO-Z	Z-Bracket, 2 pcs.	R1.591.0005.0	1
SLX-MO-TNUTM6	Set slot nut with M6-screw thread, 10 pcs.	R1.591.0001.0	1
SLX-MO-TNUTM6M4	Set slot nut with M6- and M4-screw thread, 10 pcs.	R1.591.0002.0	1
SLX-MO-TNUTM6M5	Set slot nut with M6- and M5-screw thread, 10 pcs.	R1.591.0003.0	1
SLX-MO-RO-S	Rotative bracket with shockabsorber, 70mm lang, 2 pcs.	R1.591.0007.0	1
SLX-MO-RO270-S	Rotative bracket with shockabsorber, 270mm lang, 2 pcs.	R1.591.0008.0	1
SLX-MO-CLIP	Clamp bracket, for installation in device column	R1.591.0009.0	1
SLX-MO-CLIP2	Set clamp bracket, for installation in device column, 2 pcs.	R1.591.0010.0	1
SLX-MO-RO2	Rotative bracket 360°, 2 pcs., inkl. 1 pcs. SLC cylinder	R1.591.0020.0	1
SLX-MO-RO2S	Rotative bracket 360°, 2 pcs., vibration damped, incl. 1 pc. SLC cylinder	R1.591.0021.0	1
SLX-MO-RO2-G	Rotative bracket 360°, 2 pcs., incl. 2 pcs. SLC cylinder, for guest/middle-guest-systems	R1.591.0022.0	1
SLX-MO-RO2S-G	Rotative bracket 360°, 2 pcs., vibration damped, incl. 2 pcs. SLC cylinder, for guest/middle-guest-systems	R1.591.0023.0	1
SLX-MO-RO3	Swiveling mounting bracket for slot mounting ± 8°	R1.591.0024.0	1
SLX-MO-2RO3	Swiveling mounting bracket for slot mounting ± 8°	R1.591.0025.0	1
SLX-MO-2RO3S	Swiveling mounting bracket for slot mounting, vibration damped ± 8°, 2 pcs.	R1.591.0026.0	1



SERIES SLC / SLD

MOUNTING ACCESSORIES



SLX-CAB-M12

CONNECTION CABLES SLC/SLD

The connection cables **SLX-CAB-M12** (shielded and unshielded) are used for the electrical connection of series SLC/SLD by M12-connector (5- or 8-pole). For the connection of safety light grids SLD shielded cables are mandatory.



SLC-PRO

PROTECTIVE SCREEN SLC

The protective screens **SLC-PRO** are used for the protection of the front of series SLC.

OVERVIEW OF DEVICES | PART NUMBERS

Type	Description	Part no.	P.U.
SLX-CAB-M12-S0505	Connection cable M12, 5-pole, length 5m, shielded	R1.600.0505.0	1
SLX-CAB-M12-S0510	Connection cable M12, 5-pole, length 10m, shielded	R1.600.0510.0	1
SLX-CAB-M12-S0515	Connection cable M12, 5-pole, length 15m, shielded	R1.600.0515.0	1
SLX-CAB-M12-S0525	Connection cable M12, 5-pole, length 25m, shielded	R1.600.0525.0	1
SLX-CAB-M12-S0550	Connection cable M12, 5-pole, length 50m, shielded	R1.600.0550.0	1
SLX-CAB-M12-S0805	Connection cable M12, 8-pole, length 5m, shielded	R1.600.0805.0	1
SLX-CAB-M12-S0810	Connection cable M12, 8-pole, length 10m, shielded	R1.600.0810.0	1
SLX-CAB-M12-S0815	Connection cable M12, 8-pole, length 15m, shielded	R1.600.0815.0	1
SLX-CAB-M12-S0825	Connection cable M12, 8-pole, length 25m, shielded	R1.600.0825.0	1
SLX-CAB-M12-S0850	Connection cable M12, 8-pole, length 50m, shielded	R1.600.0850.0	1
SLX-CAB-M12-0505	Connection cable M12, 5-pole, length 5m, unshielded	R1.500.0505.0	1
SLX-CAB-M12-0510	Connection cable M12, 5-pole, length 10m, unshielded	R1.500.0510.0	1
SLX-CAB-M12-0515	Connection cable M12, 5-pole, length 15m, unshielded	R1.500.0515.0	1
SLX-CAB-M12-0525	Connection cable M12, 5-pole, length 25m, unshielded	R1.500.0525.0	1
SLX-CAB-M12-0550	Connection cable M12, 5-pole, length 50m, unshielded	R1.500.0550.0	1
SLX-CAB-M12-0805	Connection cable M12, 8-pole, length 5m, unshielded	R1.500.0805.0	1
SLX-CAB-M12-0810	Connection cable M12, 8-pole, length 10m, unshielded	R1.500.0810.0	1
SLX-CAB-M12-0815	Connection cable M12, 8-pole, length 15m, unshielded	R1.500.0815.0	1
SLX-CAB-M12-0825	Connection cable M12, 8-pole, length 25m, unshielded	R1.500.0825.0	1
SLX-CAB-M12-0850	Connection cable M12, 8-pole, length 50m, unshielded	R1.500.0850.0	1
SLC-PRO-0150	SLC protective glass, length: 148 mm	R1.502.0150.0	1
SLC-PRO-0225	SLC protective glass, length: 223 mm	R1.502.0225.0	1
SLC-PRO-0300	SLC protective glass, length: 298 mm	R1.502.0300.0	1
SLC-PRO-0450	SLC protective glass, length: 448 mm	R1.502.0450.0	1
SLC-PRO-0600	SLC protective glass, length: 598 mm	R1.502.0600.0	1
SLC-PRO-0750	SLC protective glass, length: 748 mm	R1.502.0750.0	1
SLC-PRO-0900	SLC protective glass, length: 898 mm	R1.502.0900.0	1
SLC-PRO-1050	SLC protective glass, length: 1048 mm	R1.502.1050.0	1
SLC-PRO-1200	SLC protective glass, length: 1198 mm	R1.502.1200.0	1
SLC-PRO-1350	SLC protective glass, length: 1348 mm	R1.502.1350.0	1
SLC-PRO-1500	SLC protective glass, length: 1498 mm	R1.502.1500.0	1
SLC-PRO-1650	SLC protective glass, length: 1648 mm	R1.502.1650.0	1
SLC-PRO-1800	SLC protective glass, length: 1798 mm	R1.502.1800.0	1
SLC-PRO-FIX2	Mounting bracket for SLC protective glass, 2 pcs.	R1.502.0002.0	1
SLC-PRO-FIX3	Mounting bracket for SLC protective glass, 3 pcs.	R1.502.0003.0	1



SERIES SLC/SLD

REFLECTORS AND REFLECTOR COLUMNS



REFLECTORS AND REFLECTOR COLUMNS SLC

The reflectors **SLX-MIR** are used for the realization of two-side guarding's in combination with series SLC.

The reflector columns **SLX-COLM** are used for the realization of two-side guarding's in combination with free-standing columns SLX-COL and series SLC.

REFLECTOR COLUMNS SLD

The reflector columns **SLD-COLM** are used for the realization of two-side guarding's in combination with free-standing columns SLX-COL and series SLD.

OVERVIEW OF DEVICES | PART NUMBERS

Type	Description	Part no.	P.U.
SLX-COLM-1000	Reflector column, persistant 1000 mm	R1.594.1000.0	1
SLX-COLM-1300	Reflector column, persistant 1300 mm	R1.594.1300.0	1
SLX-COLM-1600	Reflector column, persistant 1600 mm	R1.594.1600.0	1
SLX-COLM-1900	Reflector column, persistant 1900 mm	R1.594.1900.0	1
SLX-MIR-0150	Reflector, length: 210 mm	R1.595.0150.0	1
SLX-MIR-0300	Reflector, length: 360 mm	R1.595.0300.0	1
SLX-MIR-0450	Reflector, length: 510 mm	R1.595.0450.0	1
SLX-MIR-0600	Reflector, length: 660 mm	R1.595.0600.0	1
SLX-MIR-0750	Reflector, length: 810 mm	R1.595.0750.0	1
SLX-MIR-0900	Reflector, length: 960 mm	R1.595.0900.0	1
SLX-MIR-1050	Reflector, length: 1110 mm	R1.595.1050.0	1
SLX-MIR-1200	Reflector, length: 1260 mm	R1.595.1200.0	1
SLX-MIR-1350	Reflector, length: 1410 mm	R1.595.1350.0	1
SLX-MIR-1500	Reflector, length: 1560 mm	R1.595.1500.0	1
SLX-MIR-1650	Reflector, length: 1710 mm	R1.595.1650.0	1
SLX-MIR-1800	Reflector, length: 1860 mm	R1.595.1800.0	1
SLX-MIR-FIX2	Bracket for SLX-MIR-reflector, 2 pcs.	R1.595.0002.0	1
SLD-COLM2-0900	Reflector column, reflector distance: 500 mm; total heigth: 900 mm	R1.604.0900.0	1
SLD-COLM2-1060	Reflector column, reflector distance: 500 mm; total heigth: 1060 mm	R1.604.1060.0	1
SLD-COLM3-1360	Reflector column, reflector distance: 400 mm; total heigth: 1360 mm	R1.604.1363.0	1
SLD-COLM4-1360	Reflector column, reflector distance: 300 mm; total heigth: 1360 mm	R1.604.1364.0	1
SLD-MIR	Replacement reflector for SLD reflector columnn	R1.604.0001.0	1



SERIES SLC / SLD

DEVICE COLUMNS



SLX-COL



The device columns **SLX-COL** are used for a free-standing installation of series SLC/SLD.



OVERVIEW OF DEVICES | PART NUMBERS

Type	Description	Part no.	P.U.
SLX-COL-0900	Device column, profile height: 820 mm; total height: 900 mm	R1.593.0900.0	1
SLX-COL-1000	Device column, profile height: 980 mm; total height: 1060 mm	R1.593.1000.0	1
SLX-COL-1300	Device column, profile height: 1280 mm; total height: 1360 mm	R1.593.1300.0	1
SLX-COL-1600	Device column, profile height: 1580 mm; total height: 1660 mm	R1.593.1600.0	1
SLX-COL-1900	Device column, profile height: 1880 mm; total height: 1960 mm	R1.593.1900.0	1
SLX-COL-2500	Device column, profile height: 2480 mm; total height: 2560 mm	R1.593.2500.0	1
SLX-COL-BASE	Replacement pedestal for columns with spring elements	R1.593.0001.0	1
SLX-COLP-0900	2 protective glasses for SLC-COL device column; length: 820 mm	R1.592.0900.0	1
SLX-COLP-1000	2 protective glasses for SLX-COL device column; length: 980 mm	R1.592.1000.0	1
SLX-COLP-1300	2 protective glasses for SLX-COL device column; length: 1280 mm	R1.592.1300.0	1
SLX-COLP-1600	2 protective glasses for SLX-COL device column; length: 1580 mm	R1.592.1600.0	1
SLX-COLP-1900	2 protective glasses for SLX-COL device column; length: 1880 mm	R1.592.1900.0	1

SERIES SLD / SLC

OTHER ACCESSORIES



SLX-ACC-LASER



SLX-ACC-LASERCOL

The external laser-alignment device **SLX-ACC-LASER** (for direct mounting on series SLX/SLD) and **SLX-ACC-LASERCOL** (for mounting on a device column SLX-COL) are used for the adjustment of the optical system of series SLC/SLD.



SLX-ACC-TEST

The test rods **SLX-ACC-TEST** are used for functional testing of protective areas realized by series SLC.

OVERVIEW OF DEVICES | PART NUMBERS

Type	Description	Part no.	P.U.
SLX-ACC-LASERCOL	External laser adjustment device, for fixing in device column	R1.596.0003.0	1
SLX-ACC-LASER	External laser adjustment device	R1.596.0002.0	1
SLX-ACC-TEST2040	Test bar, 20/40 mm	R1.596.2040.0	1
SLX-ACC-TEST1430	Test bar, 14/30 mm	R1.596.1430.0	1
SLX-ACC-MKEY	Magnet key for activation of laser adjustment device	R1.596.0001.0	1

SERIES SLC / SLD

MUTING ACCESSORIES



SLX-MUTC-SET2P

The Muting-Set **SLX-MUTC-SET2P** is used for realizing a 2-sensor cross muting e.g. in combination with device columns SLX-COL to be ordered separately or directly onto the SLD safety light grids.

The Muting-Set **SLX-MUTC-SET4** (no figure) is used for realizing a 4-sensor-sequence-muting, e.g. in combination with device columns SLX-COL to be ordered separately or directly onto the SLD safety light grids.

The **SLX-MUTC-SET2A** or **SLX-MUTC-SET2B** muting sets (see figure below) are used to set-up a 2-sensor sequential muting system, e.g. in combination with the SLX-COL device columns to be ordered separately, or directly onto the SLD safety light grids.

OVERVIEW OF DEVICES | PART NUMBERS

Type	Description	Part no.	P.U.
SLX-MUTC-SET2P	SLX-muting-sensor-set (device column) for 2-sensor-parallel-muting, incl. 2 sensor units, 2 reflector units, pre-assembled, distance 8 m, 2 m cable with plug M12	R1.597.0008.0	1
SLX-MUTC-SET4	SLX-muting-sensor-set for 4-sensor-sequential-muting, incl. 4 sensor units, 4 reflector units, pre-assembled, distance 8 m, 2 m cable with plug M12	R1.597.0007.0	1
SLX-MUTC-SET2A	SLX-muting-sensor-set for 2-sensor-sequential-muting, incl. 2 sensor units, 2 reflector units, pre-assembled, distance 8 m, 2 m cable with plug M12	R1.597.0005.0	1
SLX-MUTC-SET2B	SLX-muting-sensor-set for 2-sensor-sequential-muting, incl. 2 sensor units, 2 reflector units, pre-assembled, distance 8 m, 2 m cable with plug M12	R1.597.0006.0	1
SLX-MUT-SENS20	Sensor element, 2 m cable with plug M12	R1.597.0012.0	1
SLX-MUT-SENS07	Sensor element, 0.7 m cable with plug M12	R1.597.0013.0	1
SLX-MUT-SENS04	Sensor element, 0.4 m cable with plug M12	R1.597.0014.0	1
SLX-MUT-REFLEX	Reflector	R1.597.0015.0	1
SLX-MUT-BOX4	Sensor connector box for 4 muting sensors	R1.597.0020.0	1
SLX-MUT-BOX4-BT	Sensor connector box for 4 muting sensors, with mounting plate	R1.597.0019.0	1
SLX-MUT-BOX4-BT-L	Sensor connector box for 4 muting sensors, with L-mounting bracket	R1.597.0021.0	1

Further muting accessories are available on request.

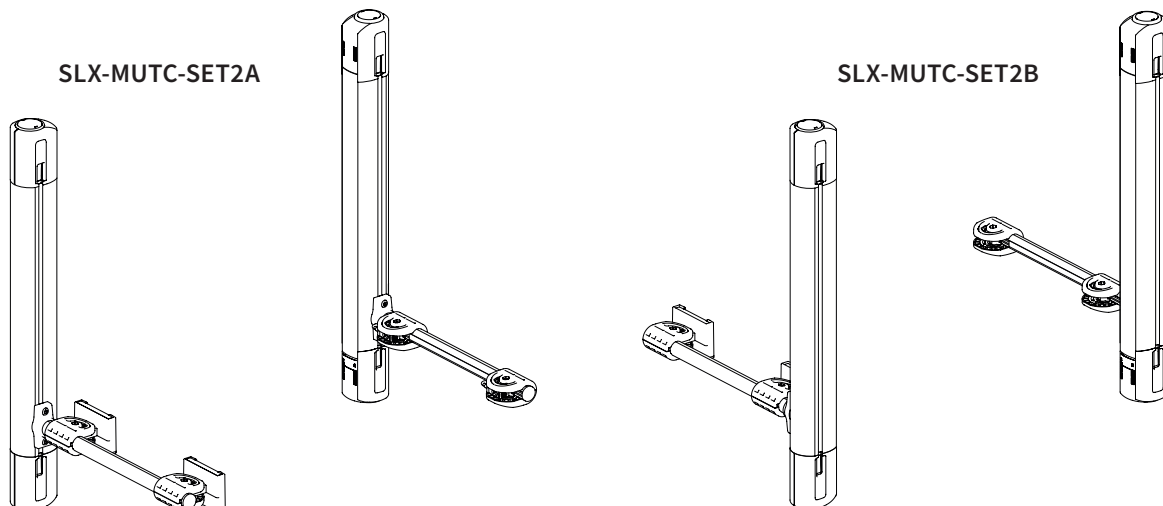



SLC PROFESSIONAL SERIES

MUTING ACCESSORIES

Example of a decentralized muting application (time-controlled 2-beam muting) with the SLC Professional series.



SLD PROFESSIONAL SERIES

MUTING ACCESSORIES

Example of a decentralized muting application (time or sequence-controlled 2-beam muting) with the SLD Professional series.





SLC/SLD SERIES

MUTING ACCESSORIES



SLX-ACC-CONF1



SLX-ACC-CONF

OVERVIEW OF DEVICES | PART NUMBERS

Type	Description	Part no.	P.U.
SLX-MUT-BOX2	SLD Professional sensor connection box for 2 muting sensors	R1.597.0017.0	1
SLX-MUT-BOX2-BT	SLD Professional sensor connection box for 2 muting sensors, with mounting plate	R1.597.0016.0	1
SLX-SBOX	SLC Professional sensor module for control, display and operating elements with 4 M12x5 bushings and M12x8 connector	R1.596.0006.0	1
SLX-SBOX-MO	SLC Professional sensor module for control, display and operating elements with 4 M12x5 bushings and M12x8 connector, incl. retaining plate and mounting parts	R1.596.0007.0	1
SLX-SBOX-CAB1	SLC Professional cable, M12, straight bushing, straight connector, length 1.5 m	R1.596.0008.0	1
SLX-SBOX-CAB1W	SLC Professional cable, M12, straight bushing, angled connector, length 1.5 m	R1.596.0009.0	1
SLX-SBOX-CAB2	SLC Professional cable, M12, straight bushing, straight connector, length 5 m	R1.596.0010.0	1
SLX-SBOX-CAB2W	SLC Professional cable, M12, straight bushing, angled connector, length 5 m	R1.596.0011.0	1
SLX-SBOX-CAB3	SLC Professional cable, M12, straight bushing, straight connector, length 15 m	R1.596.0012.0	1
SLX-SBOX-CAB3W	SLC Professional cable, M12, straight bushing, angled connector, length 15 m	R1.596.0013.0	1
SLX-ACC-CONF1	Display and acknowledgment unit	R1.596.0005.0	1
SLX-ACC-CONF	Display and acknowledgment unit, 2x connection cable M12	R1.596.0004.0	1

SLC/SLD SERIES

ACCESSORIES FOR CASCADING

The **SLX-CAS-MO1** angle bracket permits a mechanically stable and simple connection between the cascading SLC light curtains (90° connection).



SLX-CAS-MO1



SLX-CASPLUG



If the cascading SLC light curtains are to be used individually (i.e. not cascaded), corresponding **SLX-CASPLUG** terminating plugs must be attached to the connection cables.

OVERVIEW OF DEVICES | PART NUMBERS

Type	Description	Part no.	P.U.
SLX-CAS-MO1	L-angle bracket, 1 piece, incl. screws, shims and slot nuts	R1.598.0006.0	1
SLX-CAS-MO2	L-angle bracket, 2 pieces, incl. screws, shims and slot nuts	R1.598.0007.0	1
SLX-CASCAB1	Host/Guest extension cable, length 2 m	R1.598.0001.0	1
SLX-CASCAB2	Host/Guest extension cable, length 5 m	R1.598.0002.0	1
SLX-CASPLUG-T	Terminating plug for SLC transmitter host devices	R1.598.0003.0	1
SLX-CASPLUG-R	Terminating plug for SLC receiver host devices	R1.598.0004.0	1
SLX-CASPLUG-TR	Terminating plug set for SLC transmitter and receiver host devices	R1.598.0005.0	1

SERIES SENC

SAFE HTL INCREMENTAL ENCODER



SENC-58H WITH HOLLOW SHAFT



SENC-58S WITH SOLID SHAFT

APPLICATIONS FOR SAMOS®PRO COMPACT PLUS

- Safe monitoring of motors, drives or shafts
- Rotational speed, rotational direction or position monitoring to EN/IEC 61800-5-2
- Shutdown monitoring for commissioning or maintenance
- Safe direction detection (SDI) for rolls, gates or machines
- Safely reduced speed (SLS) for setup mode or jog mode
- Safely limited position (SLP) for rotative or linear axes

FEATURES

- Rotational speed or position monitoring to SIL3 and PLe to EN/IEC 61508 / EN ISO 13849
- Special form fit with the positive lock for hollow shafts
- Compact 58 flange size with minimum space requirement inside the machine
- Flange size 90 mm for harsh applications
- Flexible mounting with hollow shaft, solid shaft or axial connector
- Compatible HTL output for fast safe inputs on samos®PRO COMPACT PLUS
- Resolutions from 360 ppr, 512 ppr and 1024 ppr depending on accuracy requirement
- PUR encoder cable resistant to oil, UV, ozone and solvents
- Over 100,000 hours of service life from mounting at hollow shaft encoder
- Maximum peak speed of 9000 rpm and continuous speed of 4000 rpm

TYPE CODE

		SENC-	xxx	xx	xxx	xxxx	x
Shaft type and sizes	Solid shaft, size 58 mm		58S				
	Hollow shaft, size 58 mm		58H				
	Solid shaft, size 90 mm		90S				
	Hollow shaft, size 90 mm		90H				
Shaft diameter	10 mm shaft diameter (58S only)			10			
	14 mm shaft diameter (58H only)			14			
	11 mm shaft diameter (90S only)			11			
	30 mm shaft diameter (90H only)			30			
Electronic system	Supply voltage 11-30 V, digital HTL output (AA/, BB/, ZZ/)				HTL		
Resolution	360 ppr (ppr: pulse/revolution) (58S and 58H only)					0360	
	512 ppr (ppr: pulse/revolution)					0512	
	1024 ppr (ppr: pulse/revolution)					1024	
Connection orientation	Axial						A
	Radial						R

SAFETY-RELEVANT DATA

	PFD avg	PFH	MTTFd	DCavg	Mission Time	SIL	PL
Rotational speed monitoring (partially redundant) at 40 °C	6.60E-05	7.53E-10	1515	99.00 %	20 years	SIL3	PLe / Cat4
Rotational speed monitoring (partially redundant) at 80 °C	2.97E-04	3.39E-09	336	99.00 %	20 years	SIL3	PLe / Cat4
Position monitoring (single channel) at 40 °C	6.60E-05	7.53E-10	1515	99.00 %	20 years	SIL3	PLe / Cat4
Position monitoring (single channel) at 80 °C	2.97E-04	3.39E-09	336	99.00 %	20 years	SIL3	PLe / Cat4

SERIES SENC

SAFE HTL INCREMENTAL ENCODER

TYPICAL ARCHITECTURE

The integration of encoders for speed monitoring in a safety loop is possible in various configurations. Various solutions, depending on the existing safety level and/or existing equipment, are presented below.

NOTE:

The use of encoders in a safety loop requires external monitoring of the encoder signals. The safety modules offered by Wieland meet these requirements in a manner that is transparent for the user.

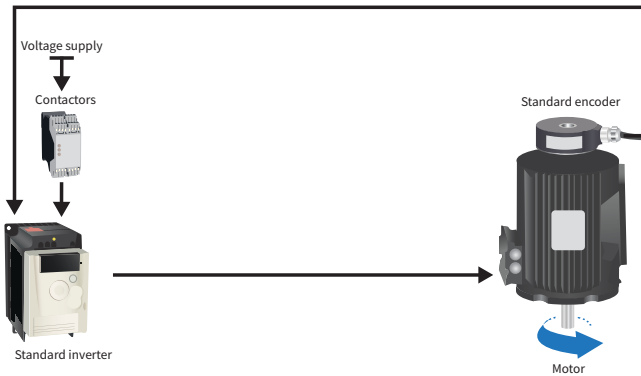

STANDARD INSTALLATION WITHOUT SIL CERTIFICATION

Safety level: 0

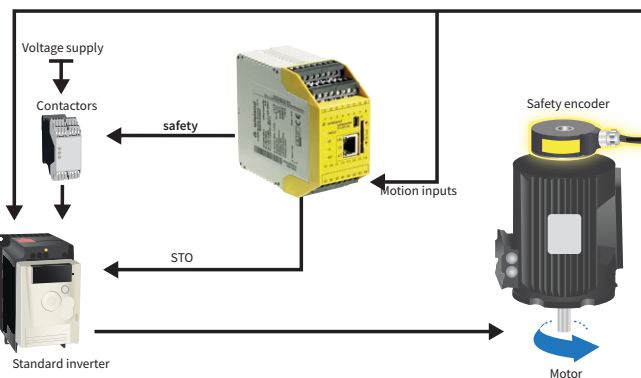

SOLUTION FOR MODULAR SAFETY

Safety level: to SIL3/PLe

Establishing conformity of an existing system

Problem-free integration: +++
Cost-effective solution: +++

New design

Problem-free integration: +++
Cost-effective solution: ++

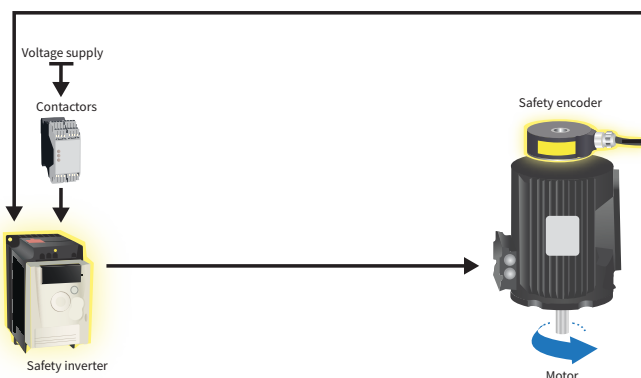

SOLUTION FOR INTEGRATED SAFETY

Safety level: to SIL3/PLe

Establishing conformity of an existing system

Problem-free integration: +
Cost-effective solution: +

New design

Problem-free integration: +++
Cost-effective solution: +++

SERIES SENC

SAFE HTL INCREMENTAL ENCODER



TECHNICAL DATA				
Function	SENC-58Sxx	SENC-58Hxx	SENC-90S	SENC-90H
Incremental rotary encoder	Logging of position or angle changes via rectangular pulses with photoelectric sensing			
Nominal voltage U_N	24 V DC			
Operating voltage range U_B	11 – 30 V DC			
Galvanic isolation supply circuit - output circuit	No			
Supply current	100 mA without load			
Electrical data				
Output signals	Digital HTL signals (11-30 V DC)			
PIN coding	A, A/, B, B/ for safe incremental pulses 0, 0/ for index pulse (no internal plausibility check)			
Color coding of encoder cable (CABLE-M23CCW...)	A: gray, A/: pink, B: brown, B/: green, 0: red, 0/: black, +V: blue and green/brown, 0V: white and white/green			
Resolution	360 ppp, 512 ppp and 1024 ppp			1024 ppp On request: 360 und 512 ppp
Current per channel pair	40 mA			
Short circuit strength	Yes			
Protection against polarity reversal	Yes			
Mechanical data				
DIN-size	58 mm		90 mm	
Shaft type	Solid shaft	Hollow shaft	Solid shaft	Hollow shaft
Shaft diameter	1000 mm	14 mm	11 mm 12 mm on request	30 mm (reduction via reducing bushes possible)
Housing material	Powder-coated, die-cast zinc			
Flange material	Aluminum			
Shaft material	AISI 303 stainless steel			
Bearing	6800 series – sealed	6803 series – sealed	6001 series – sealed	6807 series – sealed
Maximum loads	Axial: 40 N, radial: 80 N	Axial: 20 N, radial: 40 N	Axial: 100 N, radial: 200 N	Axial: 25 N, radial: 50 N
Shaft moment of inertia	< 2800 g/mm ²	< 9500 g/mm ²	< 23 500 g/mm ²	< 120 000 g/mm ²
Static/dynamic torque	5 / 35 mN/m	10 / 85 mN/m	20 / 150 mN/m	30 / 300 mN/m
Max. peak rotational speed	9000 rpm	9000 rpm	9000 rpm	6000 rpm
Max. continuous rotational speed	6000 rpm	4000 rpm	6000 rpm	3500 rpm
Theor. mechanical service life*	> 29.7/10 ⁹ revolutions / 82,365 hours	> 24/10 ⁹ revolutions / 100,000 hours	> 7.25/10 ⁹ revolutions / 20,147 Stunden	> 18/10 ⁹ revolutions / 100,000 Stunden
Weight (approx.)	0.300 kg	0.280 kg	1.0 kg	0.650 kg
General data				
Protection class as per DIN 60529	IP65			
Ambient temperature / storage temperature	-25°C – +85°C / -20°C – +85°C			
Standards	EN/ IEC 61508, IEC 13849-1, IEC 61800-5-2, IEC 62061			
Approvals	CE, TÜV, cULus (in process)			

* continuous max. rotational speed – ½ max. load – to ISO 281:1990, L10

OVERVIEW OF DEVICES | PART NUMBERS

Type	Description	Part. no.	P.U.
SENC-58S10HTL0360A	Safe HTL encoder, SIL3, PLe, solid shaft, size 58mm, 360ppr, axial	R1.450.1010.0	1
SENC-58S10HTL0360R	Safe HTL encoder, SIL3, PLe, solid shaft, size 58mm, 360ppr, radial	R1.450.1020.0	1
SENC-58S10HTL0512A	Safe HTL encoder, SIL3, PLe, solid shaft, size 58mm, 512ppr, axial	R1.450.1030.0	1
SENC-58S10HTL0512R	Safe HTL encoder, SIL3, PLe, solid shaft, size 58mm, 512ppr, radial	R1.450.1040.0	1
SENC-58S10HTL1024A	Safe HTL encoder, SIL3, PLe, solid shaft, size 58mm, 1024ppr, axial	R1.450.1050.0	1
SENC-58S10HTL1024R	Safe HTL encoder, SIL3, PLe, solid shaft, size 58mm, 1024ppr, radial	R1.450.1060.0	1
SENC-58H14HTL0360R	Safe HTL encoder, SIL3, PLe, hollow shaft, size 58mm, 360ppr, radial	R1.450.1110.0	1
SENC-58H14HTL0512R	Safe HTL encoder, SIL3, PLe, hollow shaft, size 58mm, 512ppr, radial	R1.450.1120.0	1
SENC-58H14HTL1024R	Safe HTL encoder, SIL3, PLe, hollow shaft, size 58mm, 1024ppr, radial	R1.450.1130.0	1
SENC-90S11HTL1024A	Safe HTL encoder, SIL3, PLe, solid shaft, size 90mm, 1024ppr, axial	R1.450.1250.0	1
SENC-90S11HTL1024R	Safe HTL encoder, SIL3, PLe, solid shaft, size 90mm, 1024ppr, radial	R1.450.1260.0	1
SENC-90H30HTL1024R	Safe HTL encoder, SIL3, PLe, hollow shaft, size 90mm, 1024ppr, radial	R1.450.1330.0	1



SERIES SENC

ACCESSORIES FOR ROTARY ENCODER LINE

Torque supports offer a high degree of rotatory stability, preventing the encoder rotating along with the shaft. Flange adapters are used to mount the encoder on a motor. The reducing bushes allow you to reduce the diameter of a hollow shaft encoder. The encoder cables from PUR with M23 connector (encoder side) and open core (controller side) offer high flexibility, ruggedness and durability.



Torque support with retaining bracket

Torque support with stator coupling

Reducing bush



Rated for maximum ruggedness and optimized safety



Safe drive with keyed joint.



Lockable, insulated reducing bushes protect against leakage currents.



A unique device for continuous hollow shafts, which effectively prevents slippage through locking pins.



Rugged mechanical design with additional bearing in the cover.

OVERVIEW OF DEVICES | PART NUMBERS

Type	Description	Part. no.	P.U.
ACCESSORIES: REDUCTION SLEEVES			
SLEEVE-90H-P-30-20	Reduction sleeve, hollow shaft, size 90mm, 30 mm shaft diameter to 20mm	R1.450.9040.0	1
SLEEVE-90H-P-30-21	Reduction sleeve, hollow shaft, size 90mm, 30 mm shaft diameter to 21mm	R1.450.9050.0	1
SLEEVE-90H-P-30-22	Reduction sleeve, hollow shaft, size 90mm, 30 mm shaft diameter to 22mm	R1.450.9060.0	1
SLEEVE-90H-P-30-23	Reduction sleeve, hollow shaft, size 90mm, 30 mm shaft diameter to 23mm	R1.450.9070.0	1
SLEEVE-90H-P-30-24	Reduction sleeve, hollow shaft, size 90mm, 30 mm shaft diameter to 24mm	R1.450.9080.0	1
SLEEVE-90H-P-30-25	Reduction sleeve, hollow shaft, size 90mm, 30 mm shaft diameter to 25mm	R1.450.9090.0	1
ACCESSORIES: COUPLING			
COUP-STATOR-58-S	Stator coupling, size 58mm, stainless-steel	R1.450.9110.0	1
COUP-TETHER-58-S	Tether arm coupling, size 58mm, stainless-steel	R1.450.9120.0	1
COUP-STATOR-90-S	Stator coupling, size 90mm, stainless-steel	R1.450.9130.0	1
COUP-STATOR-90-S	Tether arm coupling, size 90mm, stainless-steel	R1.450.9140.0	1
ACCESSORIES: FLANGE ADAPTERS			
FLANGE-58-A	Flange adapter, size 58mm, aluminium	R1.450.9210.0	1
FLANGE-90-A	Flange adapter, size 90mm, aluminium	R1.450.9220.0	1
ACCESSORIES: SHAFT			
COUP-SHAFT-58S-S-10-10	Shaft coupling, solid shaft, size 58mm, shaft diameter 10mm to 10mm	R1.450.9250.0	1
KEY-SHAFT-58S-S-04-10	Shaft key, solid shaft, size 58mm, width 4mm, length 10mm	R1.450.9260.0	10
ACCESSORIES: ENCODER CABLE			
CABLE-M23CKW-PUR-015	Encoder cable, 1,5 m, PUR, shielded	R1.450.9310.0	1
CABLE-M23CKW-PUR-030	Encoder cable, 3 m, PUR, shielded	R1.450.9314.0	1
CABLE-M23CKW-PUR-050	Encoder cable, 5 m, PUR, shielded	R1.450.9320.0	1
CABLE-M23CKW-PUR-070	Encoder cable, 7 m, PUR, shielded	R1.450.9324.0	1
CABLE-M23CKW-PUR-100	Encoder cable, 10 m, PUR, shielded	R1.450.9330.0	1
CABLE-M23CKW-PUR-150	Encoder cable, 15 m, PUR, shielded	R1.450.9335.0	1
CABLE-M23CKW-PUR-200	Encoder cable, 20 m, PUR, shielded	R1.450.9340.0	1

The fault elimination of the mechanic is not part of the device and has to be provided by the operator. For additional information (e.g. drawings and dimensions), visit the eShop at <http://eshop.wieland-electric.com>



SERIES SNH

EMERGENCY STOP BUTTONS



APPLICATIONS

- Machine and plant manufacturing
- Building machinery and transport technology

FEATURES

- For applications up to IP69K
- Tamper-proof according to EN 418/EN ISO 13850
- Modular design
- Turn-to-reset
- Integrated illumination
- Optical indication of the switching state
- Up to PL e / Category 4 (EN ISO 13849-1)
- Up to SIL_{CL} 3 (EN 62061)

FUNCTION

Emergency stop buttons of the SNH series are used on or near machines for the protection of persons. They serve the purpose of switching off / stopping machines and systems to avoid or reduce emerging or existing hazards to persons. Emergency stop buttons of the SNH series are also used to avoid damage to the machine or working material.

- **Modular design** – The emergency stop buttons of the SNH series have a modular design, various actuating elements can be freely combined with the chosen contact design.
- **Failure protection** – The emergency stop buttons of the SNH series have a special failure protection that automatically detects when a contact block is removed from the respective actuating element and then switches off safely.

DIMENSION DIAGRAM

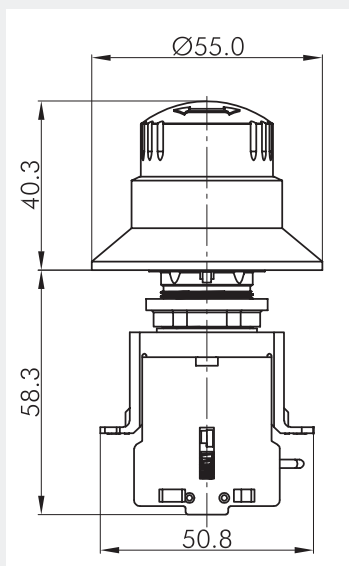

CUT-OUT DIMENSIONS

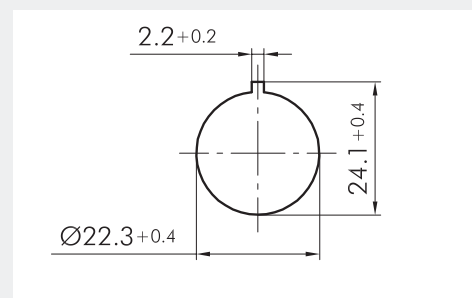

SERIES SNH

EMERGENCY STOP BUTTONS



TECHNICAL DATA

Function	
According to EN 418/EN ISO 13850	Emergency stop button
Actuator	
Housing material	Plastic
Protection degree	IP 65
Operating ambient temperature	-30 – +70 °C (without illumination), -30 – +55 °C (with illumination)
Storage temperature	-50 – +85 °C
Switching cycles	> 50000
Max. torque	2.5 Nm
Installation diameter	22.3 mm
Contact blocks	
Contact type	NC contact NC contact with failure protection NO contact
Contact material	AgNi
Switching principle	Slow-action contact
Actuating travel	6 mm
Mechanical service life	1 x 10 ⁷ switching cycles
Electrical service life	1 x 10 ⁶ switching cycles
Application category	AC15 A600: 250 V, 3A DC13 Q600: 24 V, 2A
Protection class	II
Rated insulation voltage	600 V
Min. switching voltage	5 V
Min. switching current	1 mA
Thermal continuous current I _{th}	16 A
Max. through-type thermistor	20 mΩ
Max. bounce time	20 ms
Min. positive opening travel	3 mm
Operating ambient temperature	-30 – +85 °C
Storage temperature	-50 – +85 °C
Connection technology	Screw connection
Conductor cross-section	Max. 2,5 mm ²
Standards	EN 418 /EN ISO 13850
Approvals	TÜV, cULus

SNH – EMERGENCY STOP BUTTONS



CONTACT BLOCKS



SNH 0001

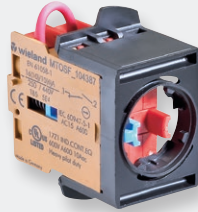

SNH 0002

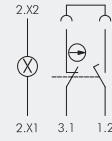

SNH 0003

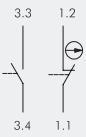

SNH 0011

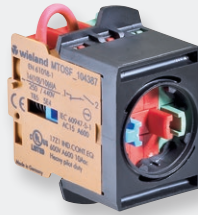
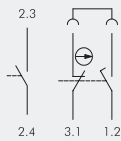

SNH 0012

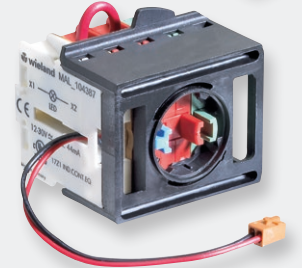
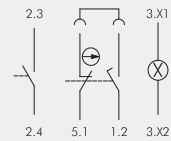

SNH 0013

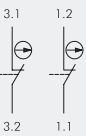

SNH 0021

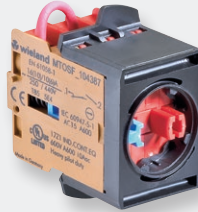
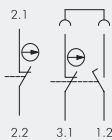

SNH 0022

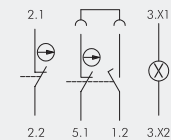

SNH 0023

ACTUATING ELEMENTS



SNH 0100



SNH 0200



SNH 0300

(up to IP 69K)



SNH 0500

SNH 0400 (WITH ILLUMINATION)

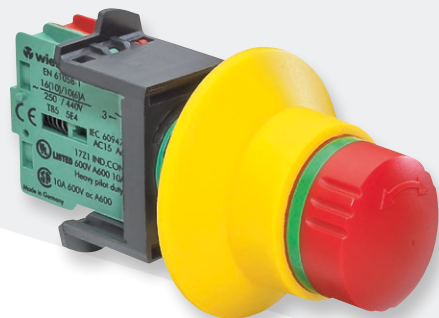

SNH – SAFE.

SNH – EMERGENCY STOP BUTTONS

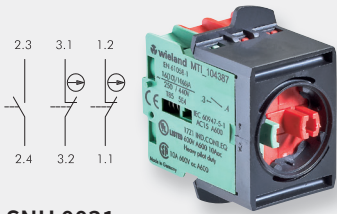

SNH 0031

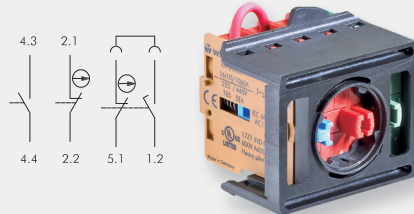

SNH 0032

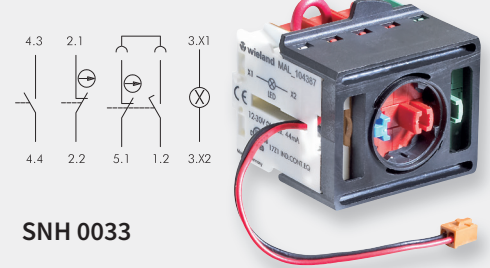

SNH 0033

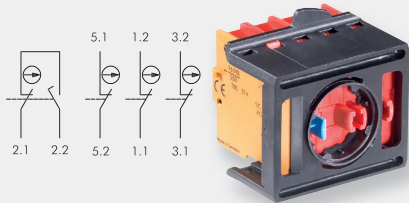

SNH 0043

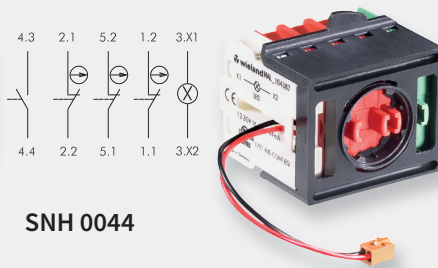

SNH 0044

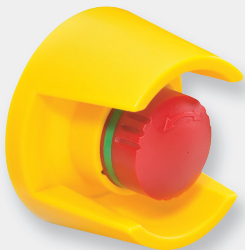

SNH 0600



SNH 0700

HOUSING



SNH 6001

sensor PRO



SIMPLE. MODULAR.

SERIES SNH

EMERGENCY STOP BUTTONS



DIMENSION DIAGRAM

ACTUATING ELEMENTS

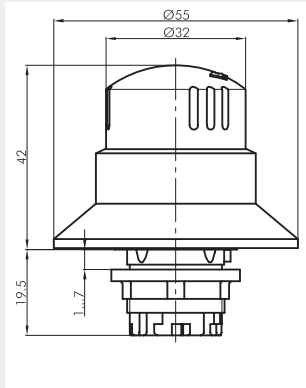

SNH 0100
SNH 0400

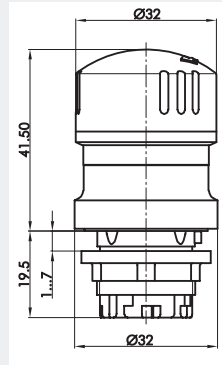

SNH 0200

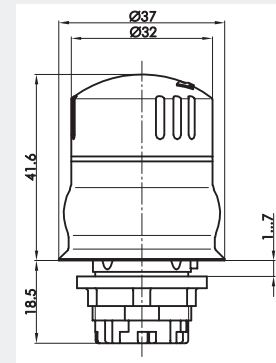

SNH 0300

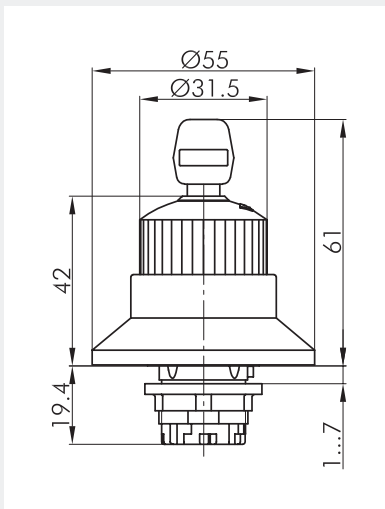

SNH 0500

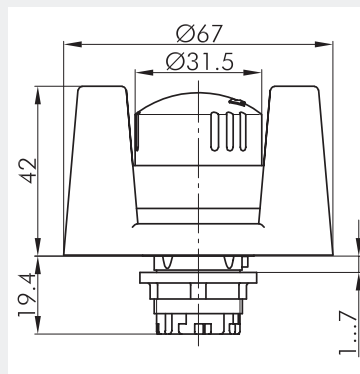

SNH 0600

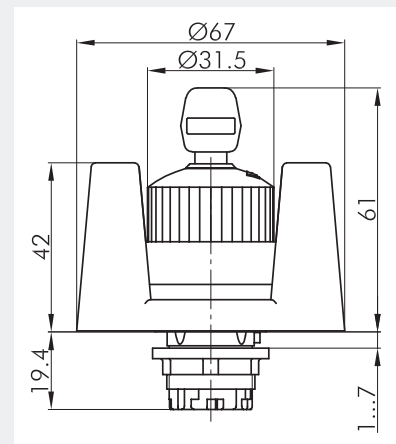

SNH 0700

HOUSING

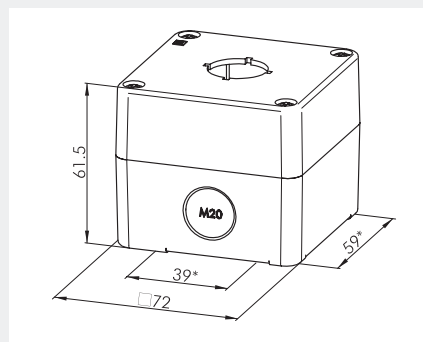

SNH 6001

SERIES SNH

EMERGENCY STOP BUTTONS



DIMENSION DIAGRAM

CONTACT BLOCKS

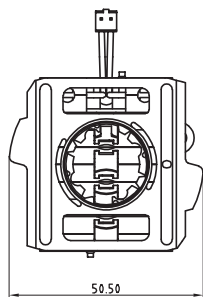
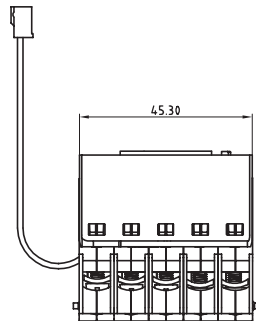
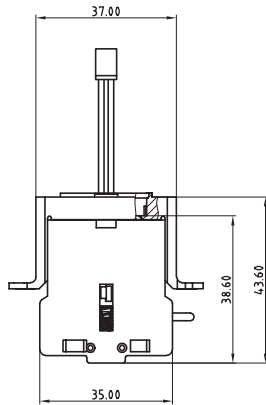

SNH 0013
SNH 0023
SNH 0032
SNH 0033
SNH 0043
SNH 0044

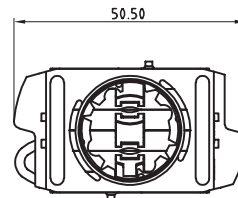
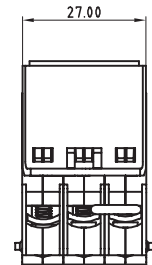
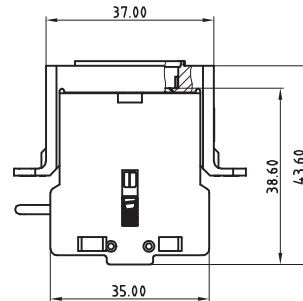

SNH 0001
SNH 0002
SNH 0003
SNH 0031
SNH 0011
SNH 0012
SNH 0021
SNH 0022

OVERVIEW OF DEVICES | PART NUMBERS

Type	Description	Part no.	P.U.
SNH 0001	Contact block, 1 NC	R1.200.0001.0	1
SNH 0002	Contact block, 1 NC (failure protection)	R1.200.0002.0	1
SNH 0003	Contact block, 1 NC (failure protection) / illumination	R1.200.0003.0	1
SNH 0011	Contact block, 1 NC / 1 NO	R1.200.0011.0	1
SNH 0012	Contact block, 1 NC (failure protection) / 1 NO	R1.200.0012.0	1
SNH 0013	Contact block, 1 NC (failure protection) / 1 NO / illumination	R1.200.0013.0	1
SNH 0021	Contact block, 2 NC	R1.200.0021.0	1
SNH 0022	Contact block, 2 NC (failure protection)	R1.200.0022.0	1
SNH 0023	Contact block, 2 NC (failure protection) / illumination	R1.200.0023.0	1
SNH 0031	Contact block, 2 NC / 1 NO	R1.200.0031.0	1
SNH 0032	Contact block, 2 NC (failure protection) / 1 NO	R1.200.0032.0	1
SNH 0033	Contact block, 2 NC (failure protection) / 1 NO / illumination	R1.200.0033.0	1
SNH 0043	Contact block, 4 NC (failure protection)	R1.200.0043.0	1
SNH 0044	Contact block, 3 NC / 1 NO / illumination	R1.200.0044.0	1
SNH 0200	Actuator (with actuation indication)	R1.200.0200.0	1
SNH 0300	Actuator IP69 (without actuation indication)	R1.200.0300.0	1
SNH 0100	Actuator (with actuation indication)	R1.200.0100.0	1
SNH 0400	Actuator (with actuation indication + illumination)	R1.200.0400.0	1
SNH 0500	Actuator (with actuation indication + key release)	R1.200.0500.0	1
SNH 0600	Actuator (with actuation indication + protective collar)	R1.200.0600.0	1
SNH 0700	Actuator (with actuation indication, protective collar and key release)	R1.200.0700.0	1
SNH 1101	Emergency stop button (SNH 0100, 1 NC)	R1.200.1101.0	1
SNH 1102	Emergency stop button (SNH 0100, 1 NC (failure protection))	R1.200.1102.0	1
SNH 1111	Emergency stop button (SNH 0100, 1 NC / 1 NO)	R1.200.1111.0	1
SNH 1112	Emergency stop button (SNH 0100, 1 NC (failure protection) / 1 NO)	R1.200.1112.0	1
SNH 1121	Emergency stop button (SNH 0100, 2 NC)	R1.200.1121.0	1
SNH 1122	Emergency stop button (SNH 0100, 2 NC (failure protection))	R1.200.1122.0	1
SNH 1131	Emergency stop button (SNH 0100, 2 NC / 1 NO)	R1.200.1131.0	1
SNH 1132	Emergency stop button (SNH 0100, 2 NC (failure protection) / 1 NO)	R1.200.1132.0	1
SNH 1143	Emergency stop button (SNH 0100, 4 NC (failure protection))	R1.200.1143.0	1
SNH 6001	Housing IP67	R1.200.6001.0	1
SNH 6010	Emergency stop adhesive plate	R1.200.6010.0	10

sensor PRO

SERIES SIN



SAFETY SWITCH WITH SEPARATED ACTUATOR AND GUARD LOCKING



APPLICATIONS

- Personnel protection on machines with dangerous machine parts which move after switching off
- Locking of a machine or an automatic process when the guard is open
- Position monitoring of guard and guard locking

FEATURES

- Suitable for locking devices in accordance with EN 14119
- Flexible use with 4 horizontal or 4 vertical actuating directions
- Integrated protection against simple bypassing
- Long service life thanks to dust- and water-proof housing and a broad operating temperature range of up to 70 °C
- Locking force 1,500 N

FUNCTION

The mechanical safety switches in the SIN series are suitable for the secure locking (guard locking) of safety doors until a hazardous machine process has ended.

The safety switches have two independent contact blocks which reflect the position of the actuator on the one hand and the position of the guard locking on the other.

The release of the entry or a shutdown of the machine in case of danger is done by evaluating the contact blocks by a suitable basic device safeRELAY or through the samos® or samos®PRO safety systems.

SPRING-ACTUATED LOCKING

The safety switch on the guard is locked automatically when the actuator reaches its end position.

The guard is unlocked by applying a current to the internal electromagnets in the safety switch.

MAGNET-ACTUATED LOCKING

The safety switch on the guard is locked when the actuator reaches its end position by applying a current to the internal electromagnet.

When the current to the internal electromagnet is switched off, the guard locking is released and the guard can be opened.

VERSATILE INSTALLATION

Thanks to the adjustable actuator head and the large selection of actuators, the safety switch can be used to implement guard locking devices for all applications in machine construction.

Universal use through 8 different actuating directions and 5 different actuators:

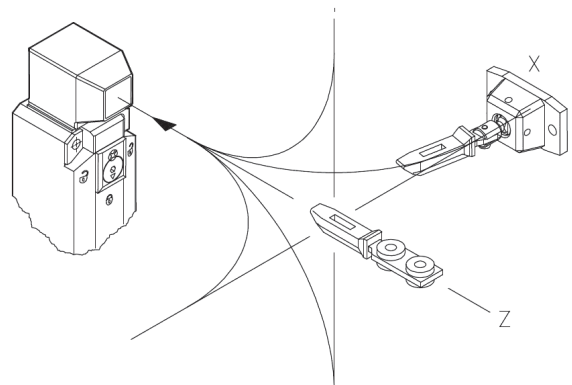

SERIES SIN



SAFETY SWITCH WITH SEPARATED ACTUATOR AND GUARD LOCKING

TECHNICAL DATA

Function	
according EN 14119	Safety switch with separated actuator and guard locking
Power supply circuit	
Rated voltage	24 V AC/DC, 110/230 V AC
Continuous output	4.4 VA (SIN 12xx: 8 VA)
Output circuit	
Contact load of conv. thermal current I_{th}	5 A
Application category	AC-15: U_e 230V, I_e 2,5 A
Mechanical life	1×10^6 switching cycles (max. 600 switching cyclesh)
Short-circuit protection	lead fuse 4 A class gL
Mechanical data	
Guard locking force	1500 Nm
Extraction force	> 27 Nm
Approach speed	max. 0,5 m/s
Dimensions (L x W x H)	170 x 42.5 x 51 mm
Mounting	4 x M5
Cable entry point	3 x M20 x 1,5
General data	
Ambient temperature	-25 - +70 °C
Wire ranges push-in terminals	1 x 0.5 -1.5 mm ²
Protection degree according to EN 60529	IP 67
Weight	0,35 kg
Standards	EN 60947-1, EN 60947-5-1, EN ISO 13849-1, EN 62061
Approvals	DEGUV, c-CSA-us, CCC



SERIES SIN

SAFETY SWITCH WITH SEPARATED ACTUATOR AND GUARD LOCKING

DIMENSIONS DIAGRAMM

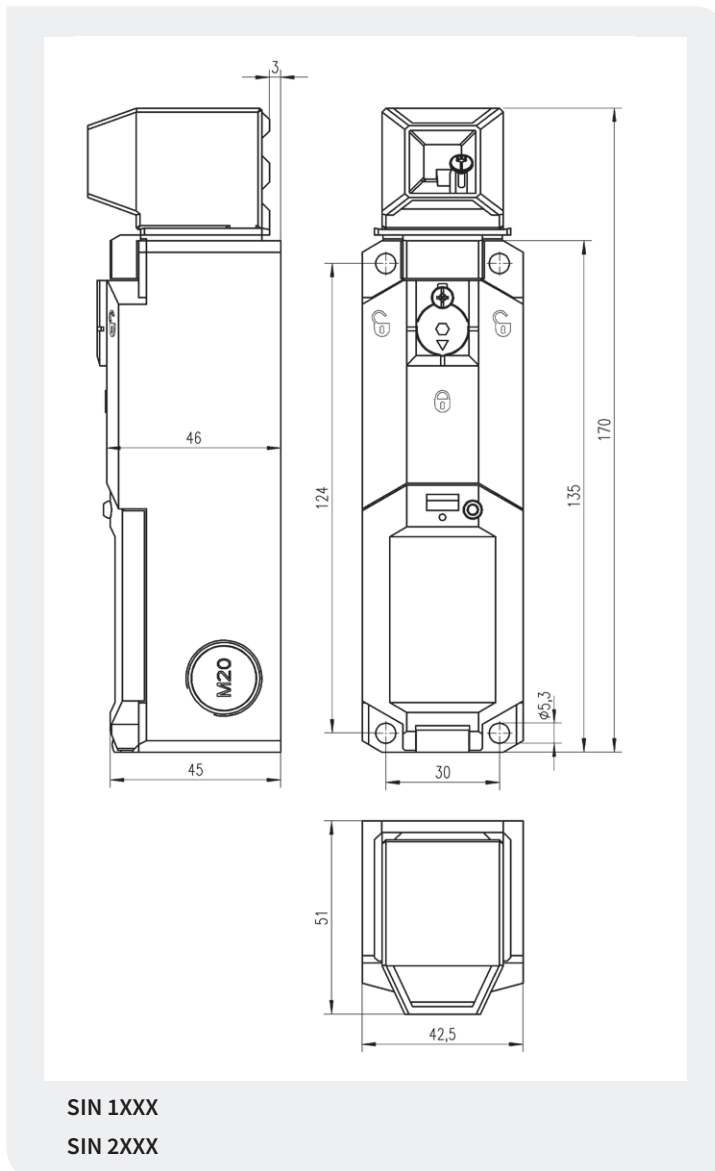

OVERVIEW OF DEVICES | PART NUMBERS SAFETY SWITCH

Type *	Locking principle	Contact assignment (actuator + guard locking)	Rated voltage	Additional features	Part. no.	P.U.
SIN 1120	Spring-actuated	2NC + 2NC	24 V AC/DC	Auxiliary release	R1.310.1120.0	1
SIN 1150	Spring-actuated	1NC/1NO + 1NC/1NO	24 V AC/DC	Auxiliary release	R1.310.1150.0	1
SIN 1130	Spring-actuated	2NC + 1NC/1NO	24 V AC/DC	Auxiliary release	R1.310.1130.0	1
SIN 1330	Spring-actuated	2NC + 1NC/1NO	24 V AC/DC	Auxiliary release, LED	R1.310.1330.0	1
SIN 1350	Spring-actuated	1NC/1NO + 1NC/1NO	24 V AC/DC	Auxiliary release, LED	R1.310.1350.0	1
SIN 1220	Spring-actuated	2NC + 2NC	110/230 V AC	Auxiliary release	R1.310.1220.0	1
SIN 1250	Spring-actuated	1NC/1NO + 1NC/1NO	110/230 V AC	Auxiliary release	R1.310.1250.0	1
SIN 1230	Spring-actuated	2NC + 1NC/1NO	110/230 V AC	Auxiliary release	R1.310.1230.0	1
SIN 2120	Magnet-actuated	2NC + 2NC	24 V AC/DC		R1.310.2120.0	1
SIN 2150	Magnet-actuated	1NC/1NO + 1NC/1NO	24 V AC/DC		R1.310.2150.0	1
SIN 2130	Magnet-actuated	2NC + 1NC/1NO	24 V AC/DC		R1.310.2130.0	1
SIN 2220	Magnet-actuated	2NC + 2NC	110/230 V AC		R1.310.2220.0	1
SIN 2250	Magnet-actuated	1NC/1NO + 1NC/1NO	110/230 V AC		R1.310.2250.0	1
SIN 2230	Magnet-actuated	2NC + 1NC/1NO	110/230 V AC		R1.310.2230.0	1

* the associated actuator must be ordered separately

SERIES SIN

ACTUATOR



DIMENSIONS DIAGRAMM

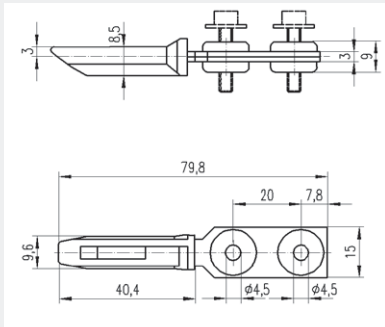

SIN 9001

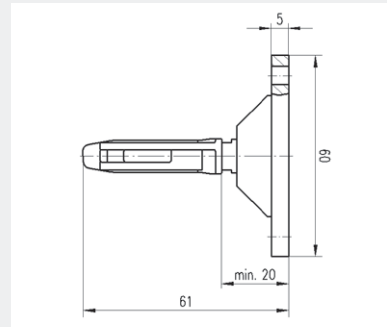

SIN 9004

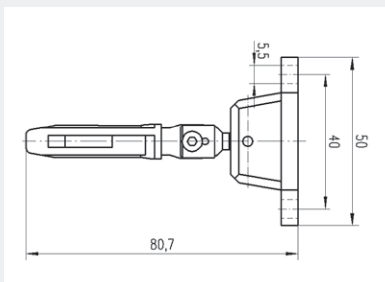

SIN 9002

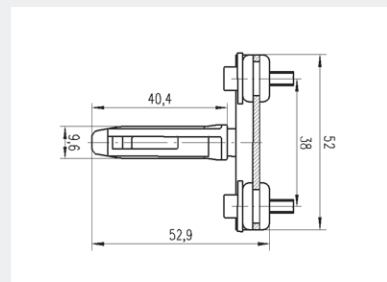

SIN 9005

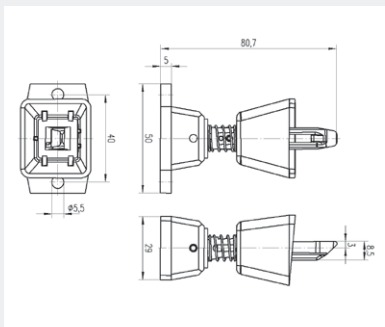

SIN 9003

APPROACH RADII

SIN 9001, 9003, 9005: R min > 400mm

SIN 9004 R min > 350mm

SIN 9002 R min > 150mm

OVERVIEW OF DEVICES | PART NUMBERS ACTUATOR

Type	Actuator	Part. no.	P.U.
SIN 9001	Standard actuator	R1.310.9001.0	1
SIN 9002	Radius actuator	R1.310.9002.0	1
SIN 9003	Radius actuator with dust protection	R1.310.9003.0	1
SIN 9004	Actuator, flexible	R1.310.9004.0	1
SIN 9005	Actuator, transverse	R1.310.9005.0	1

SERIES SMS

SAFETY SWITCH WITH SEPARATED ACTUATOR



SMS 4XXX



SMS 3XXX



APPLICATIONS

- Access protection for operators of machines with dangerous machine parts which move after switching off
- Locking of a machine or an automatic process when the guard is open
- Position monitoring of movable guards in accordance with EN 60947-5-3

FEATURES

- Flexible use with 2 horizontal or 2 vertical actuating directions
- Protection against simple bypassing in accordance with EN 14119 through multiple coding of the actuator
- Long service life thanks to dust- and water-proof housing and a broad operating temperature range of up to 80 °C.
- Increased extraction force up to 30 N
- Easy installation with adjustment via slots and final fixing via round holes

FUNCTION

The mechanical safety switches in the SMS 2000, SMS 3000 and SMS 4000 series are suitable for the reliable position monitoring of movable guards (EN 60947-5-3).

If the associated guard on the machine is opened, the hazardous machine movement is switched off.

The machine is shut down in a hazardous situation by an analysis of the contacts carried out by a suitable basic device in the safeRELAY or by one of the samos® or samos®PRO safety systems.

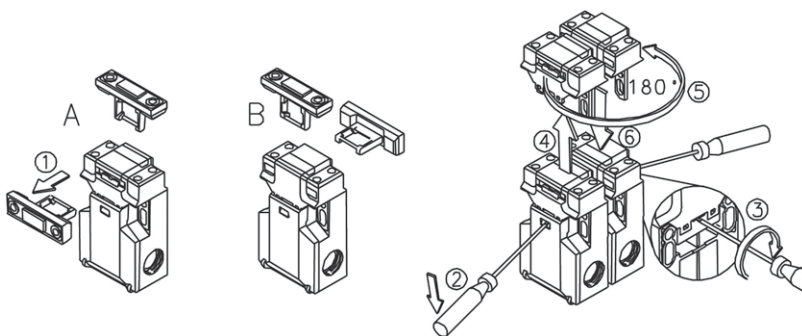

Simple installation and wiring in each application.

SERIES SMS

SAFETY SWITCH WITH SEPARATED ACTUATOR



SMS 2XXX

APPLICATIONS

- Access protection for operators of machines with dangerous machine parts which move after switching off
- Locking of a machine or an automatic process when the guard is open
- Position monitoring of guard and guard locking

FEATURES

- Flexible use with 4 horizontal or 4 vertical actuating directions
- Slim design for installation on profile systems and where there are difficult space constraints
- Protection against simple bypassing in accordance with EN 1088 through multiple coding of the actuator
- Long service life thanks to dust- and water-proof housing and a broad operating temperature range of up to 80 °C
- Increased extraction force up to 50 N



TECHNICAL DATA

Function		according EN 14119	Safety switch with separated actuator
Power supply circuit		Max. continuous thermal current I_{th}	5 A (contact assignment 1 NC or 2 NC/1 NO) 10 A (contact assignment 1 NC/1 NO or 2 NC)
Application category			AC-15: 230 V, 1.5 A (contact assignment 1 NC or 2 NC/1 NO) AC-15: 230 V, 3 A (contact assignment 1 NC/1 NO or 2 NC)
Mechanical life			1×10^6
Short-circuit protection		SMS 2xxx / SMS 3xxx	lead fuse 6 A class gL/gG
		SMS 4xxx	lead fuse 10 A class gL/gG
Mechanical data		Approach speed	$\leq 0,2$ m/s
		Extraction force	SMS 2xxx 10 N (increased extraction force 50 N) SMS 3xxx / SMS 4xxx 10 N (increased extraction force 30 N)
		Dimensions (L x W x H)	SMS 2xxx 100 x 31 x 30,5 mm SMS 3xxx 75 x 52 x 33 mm SMS 4xxx 90 x 52 x 33,5 mm
		Mounting	2 x M5
		Cable entry point	SMS 2xxx 1 x M20 x 1.5 SMS 3xxx 3 x M16 x 1.5 SMS 4xxx 3 x M20 x 1.5
General data		Ambient temperature	-30 - +80 °C
		Wire ranges screw terminals	$1 \times 0,5 - 1,5$ mm ²
		Protection degree according to EN 60529	IP 65
		Weight	0,15 kg
		Standards	EN 60947-1, EN 60947-5-1, EN ISO 13849-1, EN 62061
		Approvals	TÜV, UL, c-CSA-us

SERIES SMS

SAFETY SWITCH WITH SEPARATED ACTUATOR



DIMENSIONS DIAGRAMM

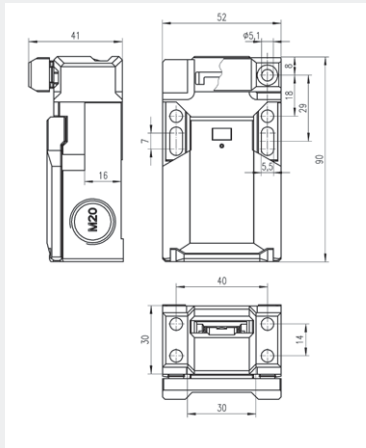

SMS 4XXX

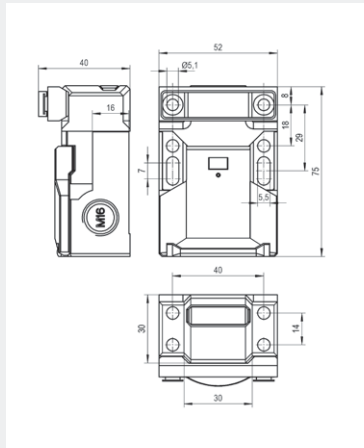

SMS 3XXX

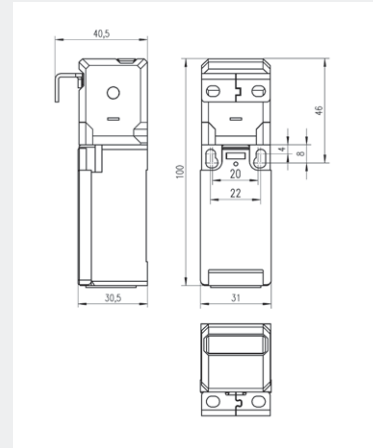

SMS 2XXX

OVERVIEW OF DEVICES | PART NUMBERS SAFETY SWITCH

Type	Actuator*	Contact assignment	Extraction force	Part no.	P.U.
SMS 3010	Standard actuator	1NC	10 N	R1.320.3010.0	1
SMS 3210	Actuator for increased force	1NC	30 N	R1.320.3210.0	1
SMS 3110	Radius actuator	1NC	10 N	R1.320.3110.0	1
SMS 4040	Standard actuator	1NC/1NO	10 N	R1.320.4040.0	1
SMS 4240	Actuator for increased force	1NC/1NO	30 N	R1.320.4240.0	1
SMS 4140	Radius actuator	1NC/1NO	10 N	R1.320.4140.0	1
SMS 4020	Standard actuator	2NC	10 N	R1.320.4020.0	1
SMS 4220	Actuator for increased force	2NC	30 N	R1.320.4220.0	1
SMS 4120	Radius actuator	2NC	10 N	R1.320.4120.0	1
SMS 4070	Standard actuator	2NC/1NO	10 N	R1.320.4070.0	1
SMS 4270	Actuator for increased force	2NC/1NO	30 N	R1.320.4270.0	1
SMS 4170	Radius actuator	2NC/1NO	10 N	R1.320.4170.0	1
SMS 2040	Standard actuator 2	1NC/1NO	10 N	R1.320.2040.0	1
SMS 2240	Actuator for increased force	1NC/1NO	50 N	R1.320.2240.0	1
SMS 2020	Standard actuator 2	2NC	10 N	R1.320.2020.0	1
SMS 2220	Actuator for increased force	2NC	50 N	R1.320.2220.0	1
SMS 2070	Standard actuator 2	2NC/1NO	10 N	R1.320.2070.0	1
SMS 2270	Actuator for increased force	2NC/1NO	50 N	R1.320.2270.0	1

* The relevant actuator is included in the scope of delivery

SERIES SMS

ACTUATOR



SMS 9001
(SMS 3xxx / SMS 4xxx included in the scope of delivery)



SMS 9002

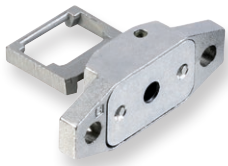

SMS 9003



SMS 9004
(SMS 2xxx included in the scope of delivery)

DIMENSIONS DIAGRAMM

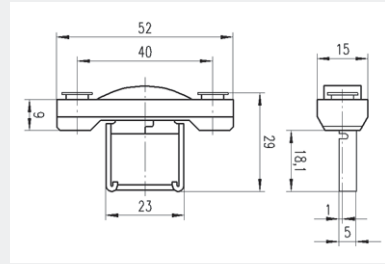

SMS 9001

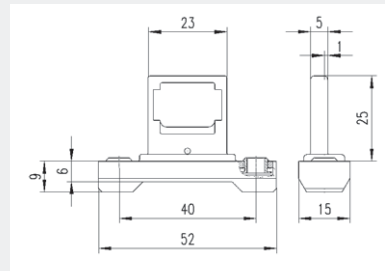

SMS 9002

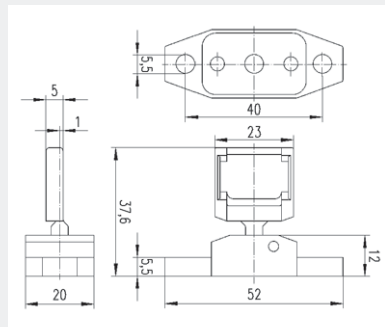

SMS 9003

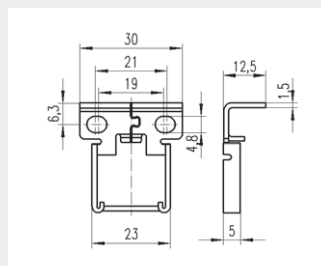

SMS 9004

OVERVIEW OF DEVICES | PART NUMBERS ACTUATOR

Type	Actuator	Part no.	P.U.
SMS 9001	Standard actuator	R1.320.9001.0	1
SMS 9002	Actuator for increased force	R1.320.9002.0	1
SMS 9003	Radius actuator	R1.320.9003.0	1
SMS 9004	Standard actuator 2	R1.320.9004.0	1



SERIES SLS

POSITION SWITCH



APPLICATIONS

- Monitoring of doors, hoods or flaps
- Position detection of moving machine parts
- Object detection in conveying systems
- End position monitoring of components
- Position detection of roller doors
- Monitoring of sliding doors

FEATURES

- Position switch to EN 50047
- Optimized contact safety: 1 mA at 24 V DC
- Tool-free rotation and replacement of actuating device
- Actuating device from metal
- Protection rating IP66 and IP67
- Self-cleaning contacts
- Mechanical service life: up to 30 million switching cycles

FUNCTION

SLS series mechanical safety switches are suitable for the safe position monitoring of movable guards (EN 60947-5-3).

If the corresponding guard on a machine is opened, the hazardous machine movement is stopped.

In a hazardous situation, the machine is shut down when the contacts are evaluated by a suitable safe RELAY basic device or by either the samos® or samos®PRO safety system.

Simple adjustment and wiring for any application.

ROTATING LEVER

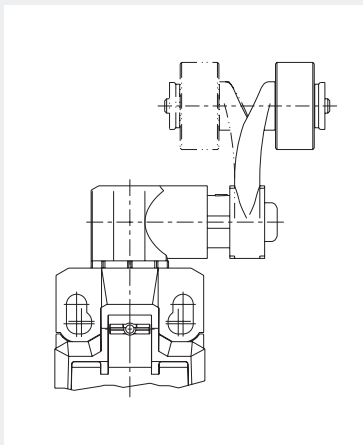

ADJUSTABLE LEVER

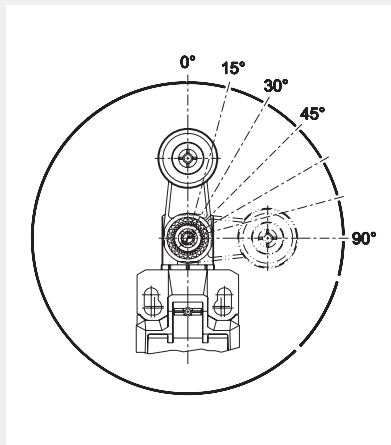

ADJUSTABLE ACTUATING DEVICE

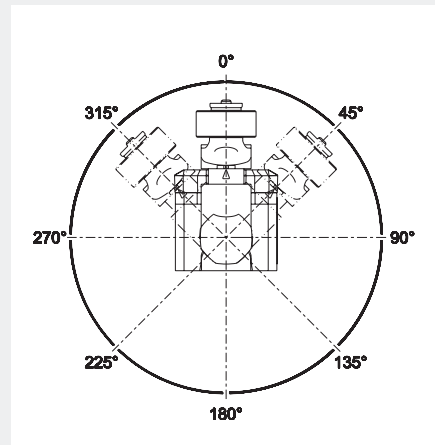

SERIES SLS

POSITION SWITCH



TECHNICAL DATA

Function	
to EN 14119	Position switch
Output circuit	
Rated operating voltage	240 V AC / 24 V DC
Max. thermal continuous current I_{th}	5 A
Min. continuous current (24 VDC)	1 mA
Utility category	AC-15: 230 V, 3 A DC-13: 24 V, 4 A
Mechanical life	10 x 10 ⁶
Short-circuit protective device	4 A class gG fuse
Mechanical data	
Housing	Thermoplastic GV (UL94-V0)
Actuation speed	0.06 m/min ≤ V ≤ 30 m/min
Operating cycles	≤ 60 / min
Mounting	2 x M5
Cable entry	1 x M20 x 1.5
Ambient operating temperature	-30°C - +70°C
General data	
Operating ambient temperature	-30 - +80 °C
Connection cross sections of screw terminal	1 x 0.34 - 1.5 mm ²
Protection class as per EN 60529	IP66, IP67 / Type 4X
Weight	≈ 0.06 kg
Standards	EN 60947-1, EN 60947-5-1
Approvals	

SERIES SLS

POSITION SWITCH



DIMENSIONS

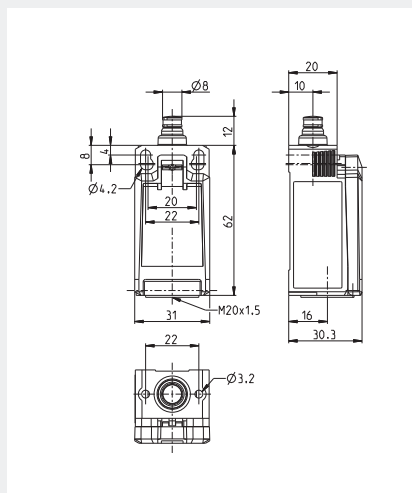

SLS 51XX

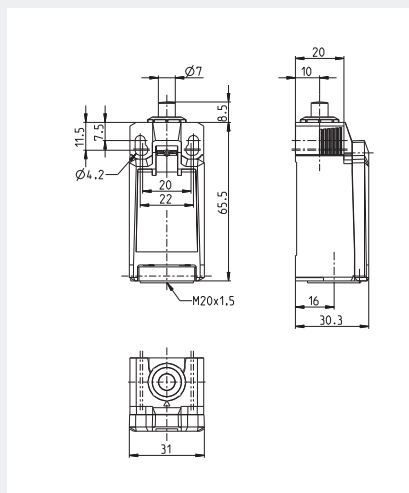

SLS 62XX

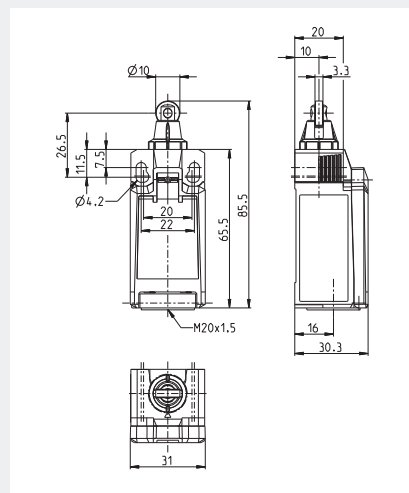

SLS 63XX

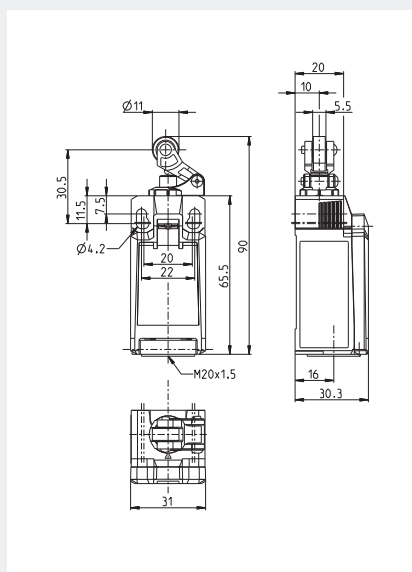

SLS 64XX

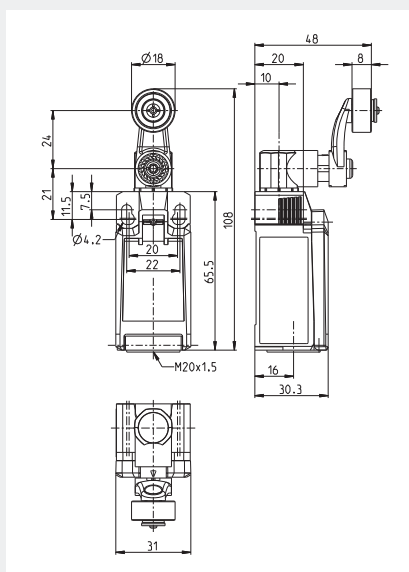

SLS 65XX

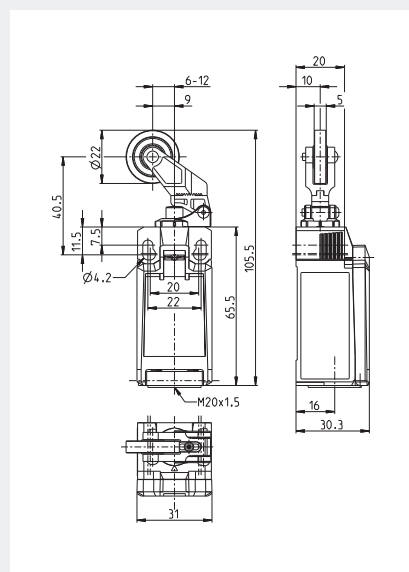

SLS 66XX

SERIES SLS

POSITION SWITCH



DIMENSIONS

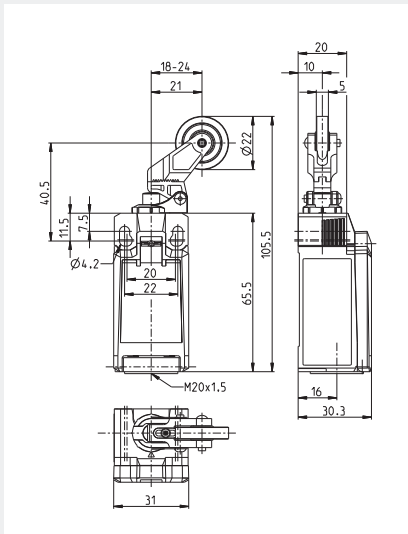

SLS 67XX

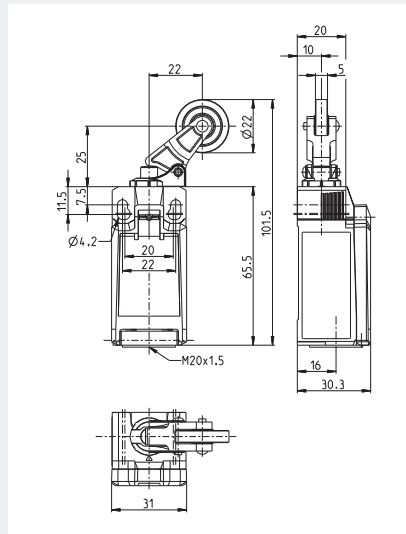

SLS 68XX

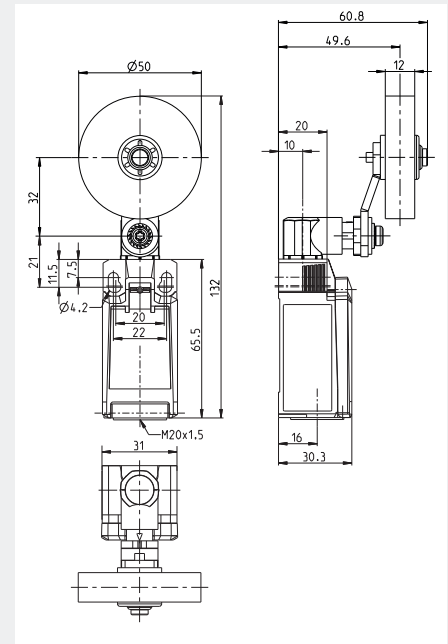

SLS 69XX

OVERVIEW OF DEVICES | PART NUMBERS

Type	Function	Actuator	Contacts	Part number	P.U.
SLS 5150	Position switch	Plunger, plastic	Snap-action contact, 1 NC / 1 NO	R1.340.5150.0	1
SLS 5130	Position switch	Plunger, plastic	Snap-action contact, 2 NC	R1.340.5130.0	1
SLS 6250	Position switch	Plunger, metal	Snap-action contact, 1 NC / 1 NO	R1.340.6250.0	1
SLS 6230	Position switch	Plunger, metal	Snap-action contact, 2 NC	R1.340.6230.0	1
SLS 6350	Roller switch	Roller, plastic	Snap-action contact, 1 NC / 1 NO	R1.340.6350.0	1
SLS 6330	Roller switch	Roller, plastic	Snap-action contact, 2 NC	R1.340.6330.0	1
SLS 6450	Roller switch	Roller, plastic	Snap-action contact, 1 NC / 1 NO	R1.340.6450.0	1
SLS 6430	Roller switch	Roller, plastic	Snap-action contact, 2 NC	R1.340.6430.0	1
SLS 6550	Roller switch	Roller, plastic	Snap-action contact, 1 NC / 1 NO	R1.340.6550.0	1
SLS 6530	Roller switch	Roller, plastic	Snap-action contact, 2 NC	R1.340.6530.0	1
SLS 6650	Roller switch	Roller, plastic	Snap-action contact, 1 NC / 1 NO	R1.340.6650.0	1
SLS 6630	Roller switch	Roller, plastic	Snap-action contact, 2 NC	R1.340.6630.0	1
SLS 6750	Roller switch	Roller, plastic	Snap-action contact, 1 NC / 1 NO	R1.340.6750.0	1
SLS 6730	Roller switch	Roller, plastic	Snap-action contact, 2 NC	R1.340.6730.0	1
SLS 6850	Roller switch	Roller, plastic	Snap-action contact, 1 NC / 1 NO	R1.340.6850.0	1
SLS 6830	Roller switch	Roller, plastic	Snap-action contact, 2 NC	R1.340.6830.0	1
SLS 6950	Roller switch	Roller, rubber	Snap-action contact, 1 NC / 1 NO	R1.340.6950.0	1
SLS 6930	Roller switch	Roller, rubber	Snap-action contact, 2 NC	R1.340.6930.0	1



SERIES STS

NON-CONTACT SAFETY SWITCHES WITH CODING



STS 01XX



STS 02XX



APPLICATIONS

- Protection of people or machines
- Position monitoring of machine parts
- Position monitoring of doors and switches of isolating protective devices

FEATURES

- Individual coding for maximum manipulation protection
- Up to PL e / category 4 (EN ISO 13849-1)
- Up to SIL_{CL} 3 (EN 62061)
- Up to 30 sensors can be cascaded
- Automatic or manual start
- LED and semiconductor output for diagnostics
- Switching distance of 8 mm / 10 mm
- Protection class IP67 / IP69K

FUNCTION

The non-contact safety switches from the STS series are used for monitoring the position of machine parts and the position of doors and switches of isolating protective devices.

The STS series features integrated evaluation and built-in manipulation protection.

In the event of a hazard, access is approved or the machine is shut down, for example, by a device from the **safe**RELAY series or the **samos**[®] / **samos**[®]PRO safety system or by the safety switch directly.

Safety switches from the STS series are also able to switch larger loads without wear via safe outputs (OSSDs).

CONNECTION ASSIGNMENT STS WITH CABLE CONNECTION

Function	Colour
UB	BN
Safety input 1	WH
GND	BU
Safety output 1	BK
Diagnostic output	GY
Safety input 2	PK
Safety output 2	VT
EDM-start input	OG

CONNECTION ASSIGNMENT STS WITH CONNECTION M12

Function	PIN
UB	1
Safety input 1	2
GND	3
Safety output 1	4
Diagnostic output	5
Safety input 2	6
Safety output 2	7
EDM-start input	8

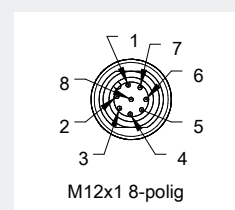



SERIES STS

NON-CONTACT SAFETY SWITCHES WITH CODING

TAILOR-MADE MANIPULATION PROTECTION

Different applications require different solutions when it comes to existing manipulation protection.

Safety switches from the STS series have 3 different coding variations, which means that they can always offer the right solution.

Coded:

The safety switch accepts every STS actuator.

Fully coded:

The safety switch only accepts the programmed-in STS actuator.

Unique:

The safety switch only accepts STS actuator delivered with it. An STS actuator cannot be programmed in.

DIVERSE INSTALLATION

The 5 actuation directions of the STS series and the maximum displacement between the actuator and switch element of 8 mm make installation easy even when the protective device to be monitored has large mechanical tolerances.

The resulting advantage is that it can be used universally on removable, rotatable, or sideways-moving protective devices.

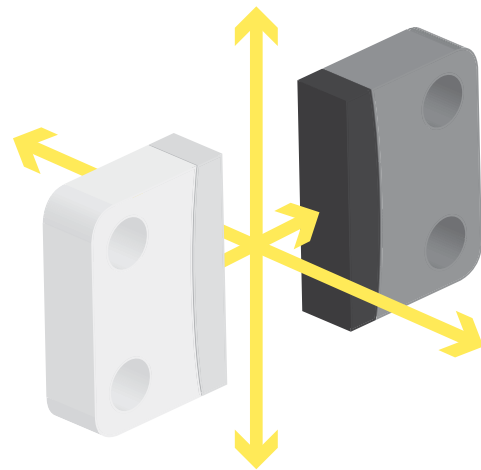

5 different actuation directions for universal use

APPLICATION

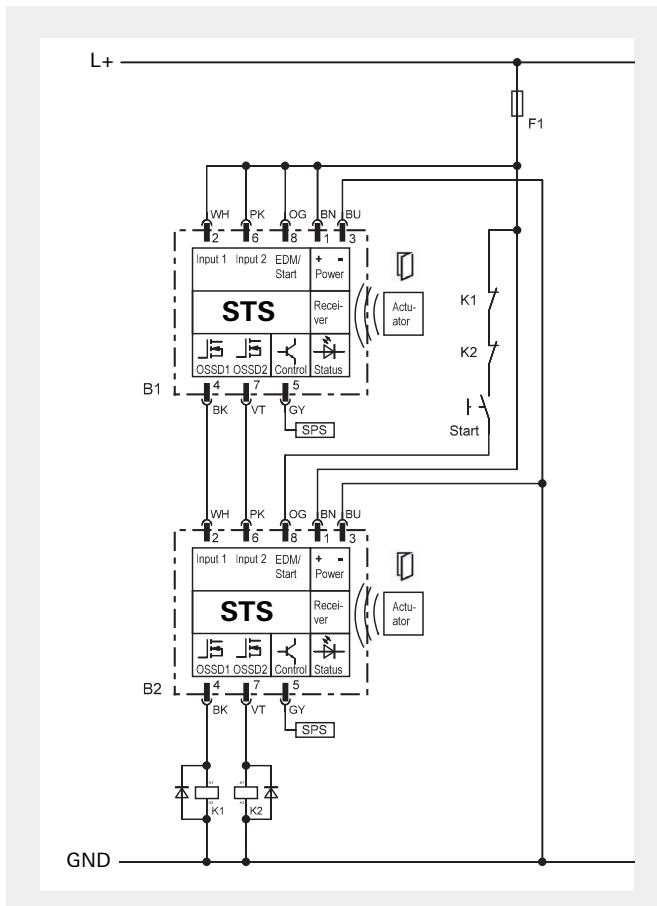

CIRCUIT DIAGRAM

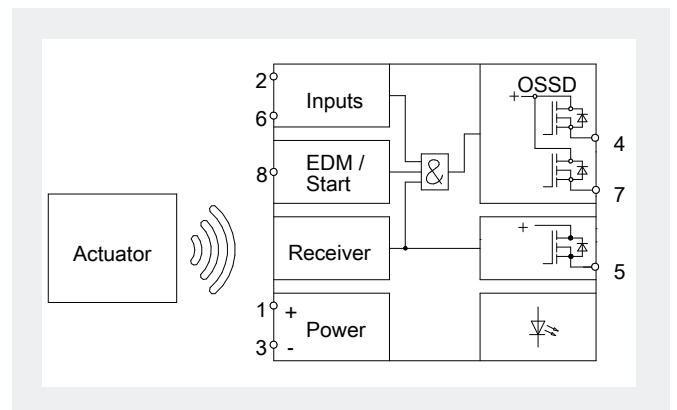

Serial wiring of 2 safety switches STS with manual start and EDM

SERIES STS

NON-CONTACT SAFETY SWITCHES WITH CODING

CIRCUIT DIAGRAM

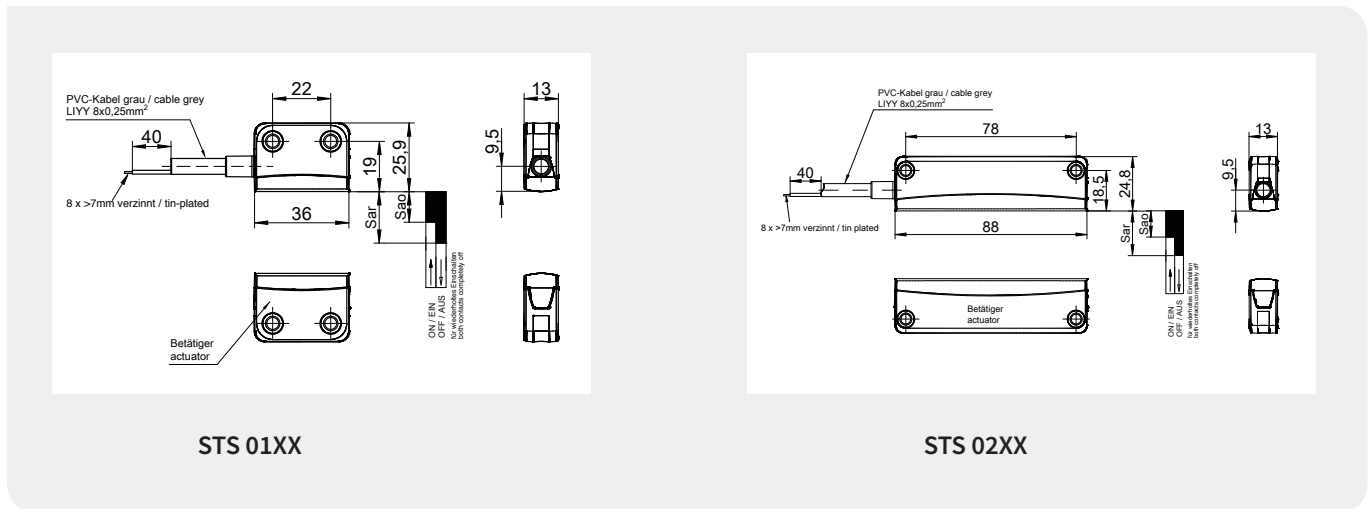

STS 01XX

STS 02XX

TECHNICAL DATA

Function	Non-contact safety switch	
Function display	LED, three-colored	
Supply circuit		
Nominal voltage U_N	24 V DC	
Operating voltage range U_B	0.9 - 1.1 x U_N	
Galvanic isolation supply circuit - output circuit	no	
Control circuits		
Number of safety inputs	2	
EDM/start input	1	
Input current, max.	2 mA	
Output circuits		
Number	OSSD	2
	Diagnostics	1
Short-circuit monitoring	yes	
Switching current, max.	OSSD	400 mA
	Diagnostics	50 mA
Switching voltage, max.	$U_B - 0.2 V$	
Series connection	max. 30 sensors	
Switching behavior		
Switching distance / (S_{ao} / S_{ar})	8 mm / 18 mm	
Hysteresis	2 mm	
Actuator displacement, max.	8 mm	
Actuation directions	Operator definable	
Switching frequency	3 Hz	
General data		
Creepage distances and clearances between the circuits	EN 60664-1	
Protection class as per EN 60529	IP67	
Operating ambient temperature	-25 °C - +70 °C	
Connection	M12 (8 pole) / cable (8 pole)	
Standards	EN ISO 13849-1, EN 62061	
Certificates / Approvals	TÜV, cULus	

SERIES STS



NON-CONTACT SAFETY SWITCHES WITH CODING

OVERVIEW OF DEVICES | PART NUMBERS

Type	Description	Coding	Part no.	P.U.
STS 0110	Switch-set, automatic start, connection M12-8	coded	R1.400.0110.0	1
STS 0113	Switch-set, automatic start, connection cable 3m	coded	R1.400.0113.0	1
STS 0114	Switch-set, automatic start, connection cable 5m	coded	R1.400.0114.0	1
STS 0116	Switch-set, automatic start, connection cable 10m	coded	R1.400.0116.0	1
STS 0130	Switch-set, automatic start, connection M12-8	fully-coded	R1.400.0130.0	1
STS 0133	Switch-set, automatic start, connection cable 3m	fully-coded	R1.400.0133.0	1
STS 0134	Switch-set, automatic start, connection cable 5m	fully-coded	R1.400.0134.0	1
STS 0136	Switch-set, automatic start, connection cable 10m	fully-coded	R1.400.0136.0	1
STS 0150	Switch-set, automatic start, connection M12-8	unique	R1.400.0150.0	1
STS 0153	Switch-set, automatic start, connection cable 3m	unique	R1.400.0153.0	1
STS 0154	Switch-set, automatic start, connection cable 5m	unique	R1.400.0154.0	1
STS 0156	Switch-set, automatic start, connection cable 10m	unique	R1.400.0156.0	1
STS 0120	Switch-set, manual start, connection M12-8	coded	R1.400.0120.0	1
STS 0123	Switch-set, manual start, connection cable 3m	coded	R1.400.0123.0	1
STS 0124	Switch-set, manual start, connection cable 5m	coded	R1.400.0124.0	1
STS 0126	Switch-set, manual start, connection cable 10m	coded	R1.400.0126.0	1
STS 0140	Switch-set, manual start, connection M12-8	fully-coded	R1.400.0140.0	1
STS 0143	Switch-set, manual start, connection cable 3m	fully-coded	R1.400.0143.0	1
STS 0144	Switch-set, manual start, connection cable 5m	fully-coded	R1.400.0144.0	1
STS 0146	Switch-set, manual start, connection cable 10m	fully-coded	R1.400.0146.0	1
STS 0160	Switch-set, manual start, connection M12-8	unique	R1.400.0160.0	1
STS 0163	Switch-set, manual start, connection cable 3m	unique	R1.400.0163.0	1
STS 0164	Switch-set, manual start, connection cable 5m	unique	R1.400.0164.0	1
STS 0166	Switch-set, manual start, connection cable 10m	unique	R1.400.0166.0	1
STS 0210	Switch-set, automatic start, connection M12-8	coded	R1.400.0210.0	1
STS 0213	Switch-set, automatic start, connection cable 3m	coded	R1.400.0213.0	1
STS 0214	Switch-set, automatic start, connection cable 5m	coded	R1.400.0214.0	1
STS 0216	Switch-set, automatic start, connection cable 10m	coded	R1.400.0216.0	1
STS 0230	Switch-set, automatic start, connection M12-8	fully-coded	R1.400.0230.0	1
STS 0233	Switch-set, automatic start, connection cable 3m	fully-coded	R1.400.0233.0	1
STS 0234	Switch-set, automatic start, connection cable 5m	fully-coded	R1.400.0234.0	1
STS 0236	Switch-set, automatic start, connection cable 10m	fully-coded	R1.400.0236.0	1
STS 0250	Switch-set, automatic start, connection M12-8	unique	R1.400.0250.0	1
STS 0253	Switch-set, automatic start, connection cable 3m	unique	R1.400.0253.0	1
STS 0254	Switch-set, automatic start, connection cable 5m	unique	R1.400.0254.0	1
STS 0256	Switch-set, automatic start, connection cable 10m	unique	R1.400.0256.0	1
STS 0220	Switch-set, manual start, connection M12-8	coded	R1.400.0220.0	1
STS 0223	Switch-set, manual start, connection cable 3m	coded	R1.400.0223.0	1
STS 0224	Switch-set, manual start, connection cable 5m	coded	R1.400.0224.0	1
STS 0226	Switch-set, manual start, connection cable 10m	coded	R1.400.0226.0	1
STS 0240	Switch-set, manual start, connection M12-8	fully-coded	R1.400.0240.0	1
STS 0243	Switch-set, manual start, connection cable 3m	fully-coded	R1.400.0243.0	1
STS 0244	Switch-set, manual start, connection cable 5m	fully-coded	R1.400.0244.0	1
STS 0246	Switch-set, manual start, connection cable 10m	fully-coded	R1.400.0246.0	1
STS 0260	Switch-set, manual start, connection M12-8	unique	R1.400.0260.0	1
STS 0263	Switch-set, manual start, connection cable 3m	unique	R1.400.0263.0	1
STS 0264	Switch-set, manual start, connection cable 5m	unique	R1.400.0264.0	1
STS 0266	Switch-set, manual start, connection cable 10m	unique	R1.400.0266.0	1
STS 3110	Actuator for STS 011x, 012x, 013x, 014x		R1.400.3110.0	1
STS 3210	Actuator for STS 021x, 022x, 023x, 024x		R1.400.3210.0	1

sensor PRO

SERIES STS

ACCESSORIES



STS-CON-448

T-Connector for serial wiring of STS-switches



STS-CON-TER

Terminal-connector of the serial wiring



STS-CON-488

T-Connector for the extraction of the diagnostic output or coupling a restart signal into the switch (optional)



STS-CON-444

T-Connector for coupling an additional power supply into the serial wiring (optional)

DIMENSIONS DIAGRAMM

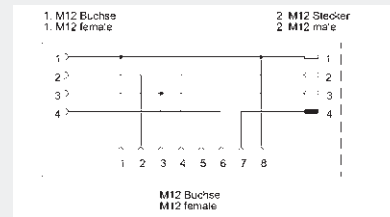

STS-CON-448

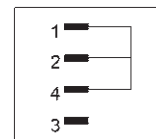

STS-CON-TER

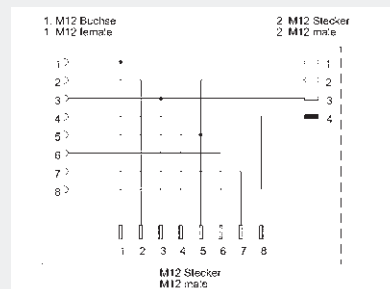

STS-CON-488

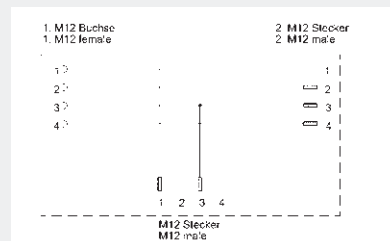

STS-CON-444

OVERVIEW OF DEVICES | PART NUMBERS

Type	Description	Part no.	P.U.
STS-CON-444	STS connector, M12-4-4-4	R1.400.9444.0	1
STS-CON-448	STS connector, M12-4-4-8	R1.400.9448.0	1
STS-CON-488	STS connector, M12-4-8-8	R1.400.9488.0	1
STS-CON-TER	STS connector, M12 terminal	R1.400.9000.0	1

SERIES STS

ACCESSORIES



APPLICATION

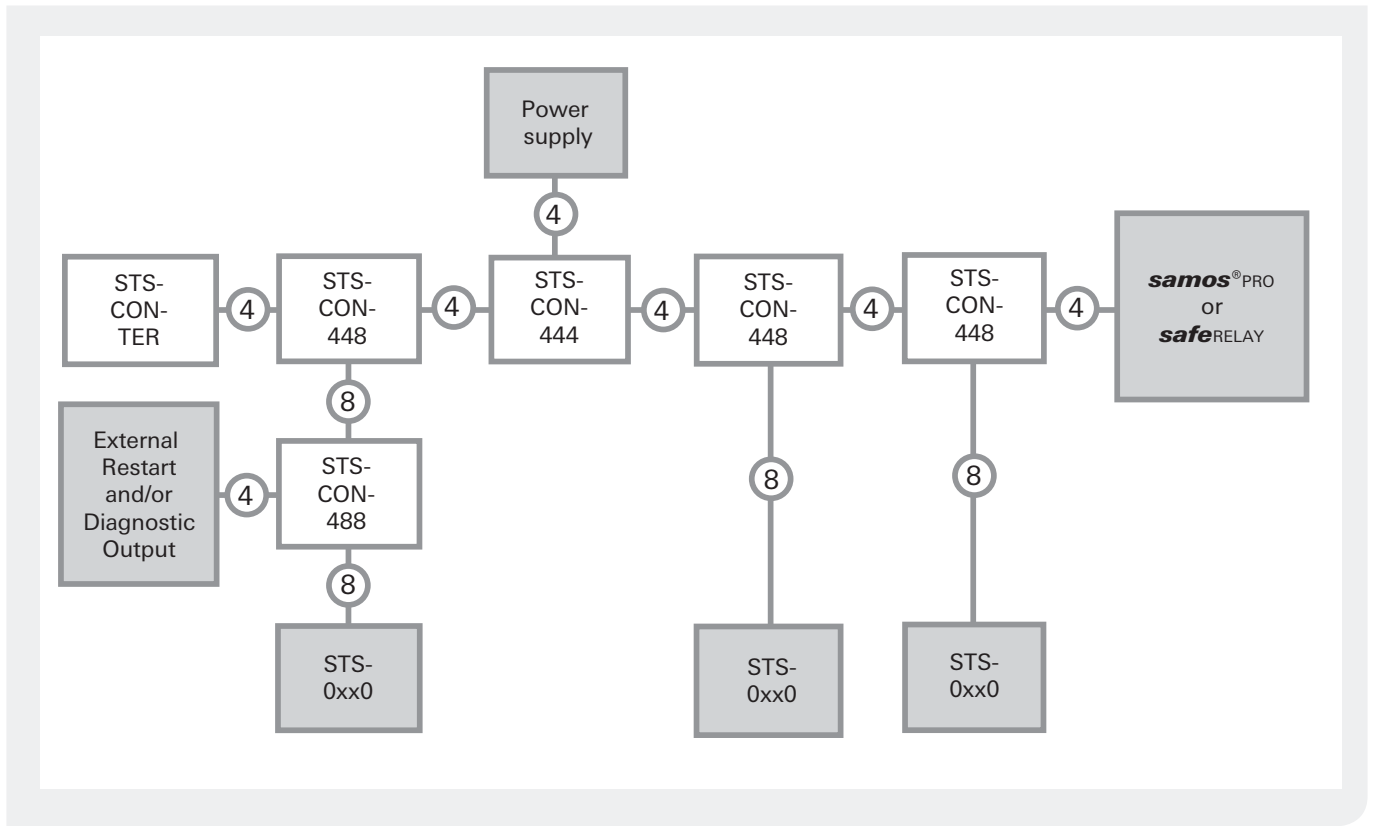

CONNECTION ASSIGNMENT WITH SARIS® CABLE M12 (FEMALE – FREE END)

Function	PIN	Color
UB	1	WH
Safety input 1	2	BN
GND	3	GN
Safety output 1	4	YE
Diagnostic output	5	GY
Safety input 2	6	PK
Safety output 2	7	BU
EDM-start input	8	RD

sensor PRO

OVERVIEW OF DEVICES | PART NUMBERS SARIS® M12 CABLE

Length	Cable M12, 4-pole, straight		Cable M12, 8-pole, straight	
	Female – male	Female – free end	Female – male	Female – free end
0.3 m	M2.K42.0344.0	–	M2.K81.0344.0	–
0.6 m	M2.K42.0644.0	–	M2.K81.0644.0	–
1 m	M2.K42.1044.0	M2.K42.1004.0	M2.K81.1044.0	M2.K81.1004.0
1.5 m	M2.K42.1544.0	M2.K42.1504.0	M2.K81.1544.0	M2.K81.1504.0
2 m	M2.K42.2044.0	M2.K42.2004.0	M2.K81.2044.0	M2.K81.2004.0
3 m	M2.K42.3044.0	M2.K42.3004.0	M2.K81.3044.0	M2.K81.3004.0
5 m	M2.K42.5044.0	M2.K42.5004.0	M2.K81.5044.0	M2.K81.5004.0
10 m	M2.K42.X044.0	M2.K42.X004.0	M2.K81.X044.0	M2.K81.X004.0



SERIES SMA

MAGNETIC SAFETY SWITCHES



SMA 01XX



APPLICATIONS

- Machine and plant manufacturing
- Packing machines
- Wood-processing machines

FEATURES

- Block-shaped design
- For harsh operating conditions
- Tamper proof
- Can be used up to PL e / Category 4 (EN ISO 13849-1)
- Degree of Protection IP67

TECHNICAL DATA

Set	SMA 011x	SMA 012x
Dimensions / mm (L x W x H)	36 x 26 x 13 mm	
Actuating distance / (Sao / Sar)	8 / 17 mm	
Directions of actuation	Front - Front / Front - Side / Side - Side	
Protection degree	IP67	
Contact type	Reed	
Contact assignment	NC / NO	NO / NO
Switching voltage	48 V DC	
Switching current	0.2 A	
Maximum cable length	20 m	

DIMENSION DIAGRAM

SMA 011X / SMA 012X

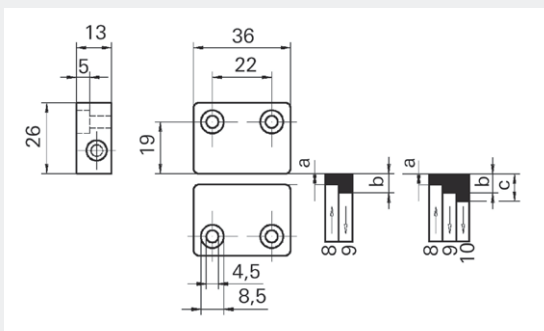

CIRCUIT DIAGRAM

SMA 011X

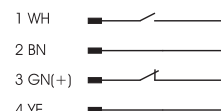

SMA 012X

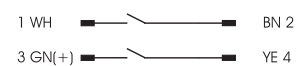

Contacts are shown in non-operated state (magnet is out of actuating distance Sar)

SERIES SMA

MAGNETIC SAFETY SWITCHES

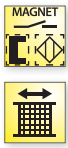

SMA 02XX
SMA 06XX



APPLICATIONS

- Machine and plant manufacturing
- Packing machines
- Wood-processing machines

FEATURES

- Rectangle-shaped design
- For harsh operating conditions
- Tamper proof
- Can be used up to PL e / Category 4 (EN ISO 13849-1)
- Degree of Protection IP67

TECHNICAL DATA

Set	SMA 021x	SMA 022x	SMA 023x/024x	SMA 061x	SMA 062x
Dimensions / mm (L x W x H)	88 x 25 x 14 mm				
Actuating distance / (Sao / Sar)	7 / 17 mm	7 / 18 mm	7 / 22 mm	4 / 16 mm	4 / 17 mm
Directions of actuation	Front - Front / Front - Side / Side - Side				
Protection degree	IP67				
Contact type	Reed				
Contact assignment	NC / NO	NO / NO	NO / NO / NC	NC / NO	NO / NO
Switching voltage	48 V DC				
Switching current	0.2 A				
Maximum cable length	20 m				

DIMENSION DIAGRAM

SMA 021X / SMA 022X / SMA 023X / SMA 024X

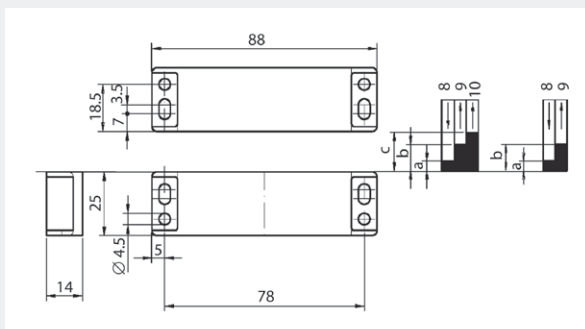

CIRCUIT DIAGRAM

SMA 021X / SMA 0219

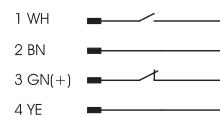

SMA 022X / SMA 0229

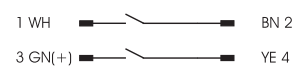

SMA 023X

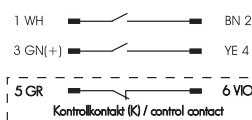

SMA 024X (WITH LED)

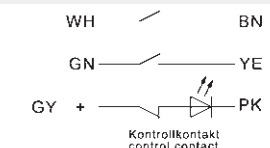

Contacts are shown in non-operated state (magnet is out of actuating distance Sar)



SERIES SMA

MAGNETIC SAFETY SWITCHES



SMA 03XX



APPLICATIONS

- Machine and plant manufacturing
- Packing machines
- Wood-processing machines

FEATURES

- Round-shaped design
- For harsh operating conditions
- Tamper proof
- Can be used up to PL e / Category 4 (EN ISO 13849-1)
- Degree of Protection IP67

TECHNICAL DATA

Set	SMA 031x	SMA 032x
Dimensions / mm (Ø x L)	M30 x 32 mm	
Actuating distance / (Sao / Sar)	7 / 20 mm	
Directions of actuation	Front - Front	
Protection degree	IP67	
Contact type	Reed	
Contact assignment	NC / NO	NO / NO
Switching voltage	48 V DC	
Switching current	0.2 A	
Maximum cable length	20 m	

DIMENSION DIAGRAM

SMA 031X / SMA 032X

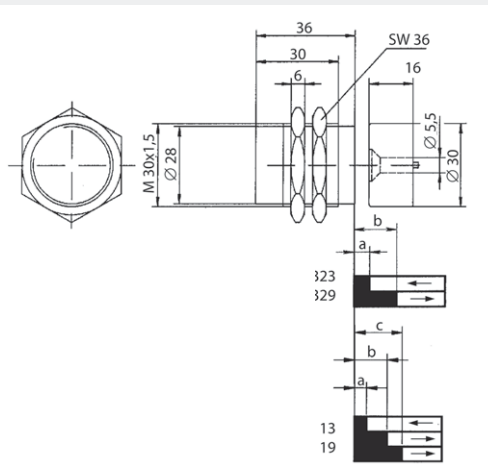

CIRCUIT DIAGRAM

SMA 031X

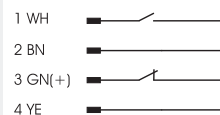

SMA 032X

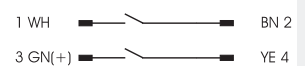

Contacts are shown in non-operated state (magnet is out of actuating distance Sar)

OVERVIEW OF DEVICES | PART NUMBERS

Type	Description	Contact	Part no.	P.U.
SMA 0113	Switch-set with cable 3 m + magnet	NC / NO	R1.100.0113.0	1
SMA 0123	Switch-set with cable 3 m + magnet	NO / NO	R1.100.0123.0	1
SMA 0119	Switch-set mit with M8 connection + magnet	NC / NO	R1.100.0119.0	1
SMA 0129	Switch-set mit with M8 connection + magnet	NO / NO	R1.100.0129.0	1
SMA 0213	Switch-set with cable 3 m + magnet	NC / NO	R1.100.0213.0	1
SMA 0223	Switch-set with cable 3 m + magnet	NO / NO	R1.100.0223.0	1
SMA 0224	Switch-set with cable 5 m + magnet	NO / NO	R1.100.0224.0	1
SMA 0226	Switch-set with cable 10 m + magnet	NO / NO	R1.100.0226.0	1
SMA 0228	Switch-set with cable 20 m + magnet	NO / NO	R1.100.0228.0	1
SMA 0233	Switch-set with cable 3 m + magnet	NO / NO / NC	R1.100.0233.0	1
SMA 0243	Switch-set with cable 3 m, LED + magnet	NO / NO / NC	R1.100.0243.0	1
SMA 0249	Switch-set with M12 connection, LED + magnet	NO / NO / NC	R1.100.0249.0	1
SMA 0219	Switch-set with M8 connection + magnet	NC / NO	R1.100.0219.0	1
SMA 0229	Switch-set with M8 connection + magnet	NO / NO	R1.100.0229.0	1
SMA 0313	Switch-set with cable 3 m + magnet	NC / NO	R1.100.0313.0	1
SMA 0323	Switch-set with cable 3 m + magnet	NO / NO	R1.100.0323.0	1
SMA 0319	Switch-set with M8 connection + magnet	NC / NO	R1.100.0319.0	1
SMA 0329	Switch-set with M8 connection + magnet	NO / NO	R1.100.0329.0	1
SMA 0613	Switch-set with cable 3 m + magnet	NC / NO	R1.100.0613.0	1
SMA 0623	Switch-set with cable 3 m + magnet	NO / NO	R1.100.0623.0	1
SMA 0626	Switch-set with cable 10 m + magnet	NO / NO	R1.100.0626.0	1
SMA 0619	Switch-set with M8 + magnet	NC / NO	R1.100.0619.0	1
SMA 0629	Switch-set with M8 + magnet	NO / NO	R1.100.0629.0	1

ACCESSORIES FOR SMA



OVERVIEW OF DEVICES | PART NUMBERS

Type	Description	Contact	Part no.	P.U.
SMA 3110	Magnet (NC / NO) for SMA 011x		R1.100.3110.0	5
SMA 3120	Magnet (NO / NO) for SMA 012x		R1.100.3120.0	5
SMA 3200	Magnet for SMA 02xx		R1.100.3200.0	5
SMA 3300	Magnet for SMA 03xx		R1.100.3300.0	5
SMA 3600	Magnet for SMA 06xx		R1.100.3600.0	5
SMA 4100	Washer for SMA 01xx		R1.100.4100.0	10
SMA 4200	Washer for SMA 02xx / SMA 06xx		R1.100.4200.0	10
SMA 5004	Cable, 5 m		R1.100.5004.0	1
SMA 5005	Cable, 10 m		R1.100.5005.0	1

Note: Suitable M12 cables (SLX-CAB) can be selected on P. 94



SMI 1001

MAGNETIC SWITCH INTERFACE



FUNCTION

The SMI 1001 connects safety switches / position switches in series. Several safety switches or position switches can be connected to safe RELAY safety switching devices or to samos® and samos®PRO safety systems and evaluated.

APPLICATIONS

- Connecting in series of two-channel sensors with contact assignment NO/NO up to PL d / Kategorie 3 (EN ISO 13849-1)

FEATURES

- Control via a maximum of 4 two-channel sensors
- Signal output for each sensor
- Optical indication of the switching state of each sensor

The SMI 1001 features status displays for the switching state of the NO circuits of the connected sensors as well as four diagnostics outputs for the display of the switching state of the NO circuits via external LEDs or a control.

DIMENSION DIAGRAM

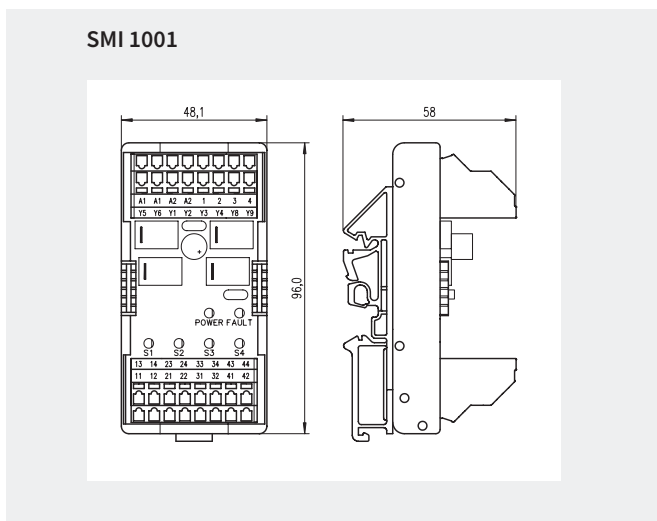

CIRCUIT DIAGRAM

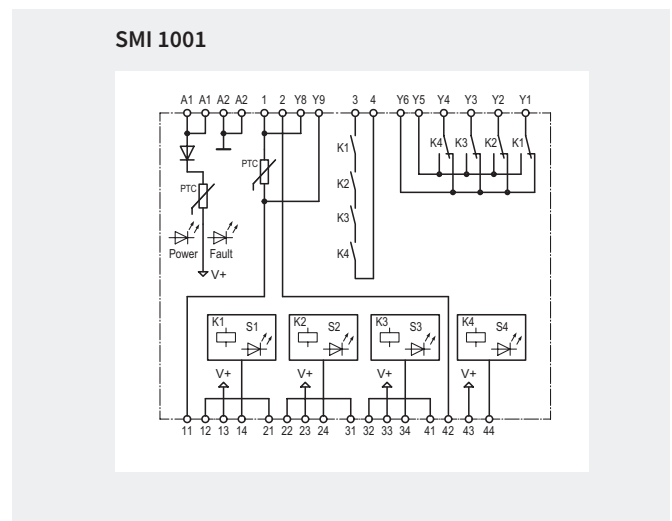

SMI 1001

MAGNETIC SWITCH INTERFACE

OVERVIEW OF DEVICES | PART NUMBERS

Type	Rated voltage	Terminals	Part no.	P.U.
SMI 1001	24 V DC	Push-in terminals, fixed	R1.100.4001.0	1

TECHNICAL DATA

Function	
Function display	1 x LEDs green, 5 x LEDs red
Power supply circuit	
Rated voltage	24 V DC
Rated consumption	1.5 W
Control circuit 11 – 44	
Max. cable length	30 m
Output circuit signal outputs Y1 – Y6	
Contact type	NO
Rated switching voltage	24 V DC
Max. switching current	0.5 A
Output circuit 1, 2, 3, 4	
Contact type	NO
Rated switching voltage	24 V DC
Max. switching current	150 mA
General data	
Creepage distances and clearances	according to EN 60664-1
Ambient temperature/ storage temperature	-25 – +55 °C / -25 – +70 °C
Wire ranges fine-stranded/ solid	0.08 – 2.5 mm ²
or fine-stranded with ferrules	0.08 – 1 mm ²
or fine-stranded with TWIN-ferrule	0.08 – 1.5 mm ²
Weight	0.1 kg
Approvals	cULus

APPLICATION

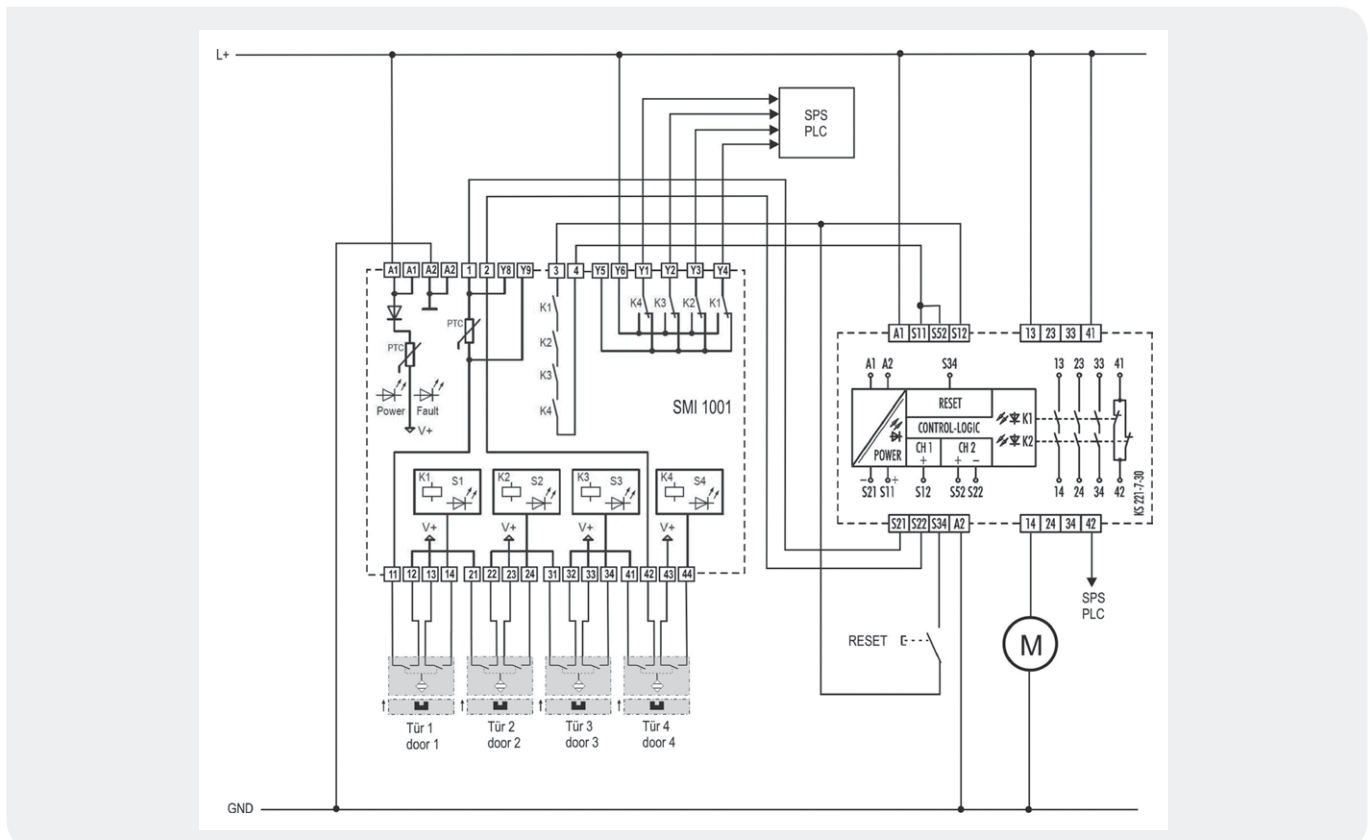



COMPLETE SOLUTIONS FOR YOUR MACHINES + PLANTS.



SAFETY

Production processes have to be safe and reliable primarily. With our extensive and complete safety solutions, from sensors to safety controllers, we sustainably minimize the risks and dangers for people and machines and guarantee safe plant operation.



CONNECTIVITY

Your goal is fast installation and commissioning without any errors. Put your faith in our smart and standardized installation systems with pre-assembled systems for flexible usage in an industrial environment. Our components are internationally approved, save time and money during installation thanks to our plug & play principle, and are maintenance-free.



COMMUNICATION

Ethernet network structures are a standard feature of machines these days. Equipment and machinery are increasingly interconnected so that data can be acquired for control tasks for the purpose of remote maintenance or to optimize processes. We offer an extensive, future-oriented portfolio including our own IIoT cloud solution to be prepared today for “tomorrow”

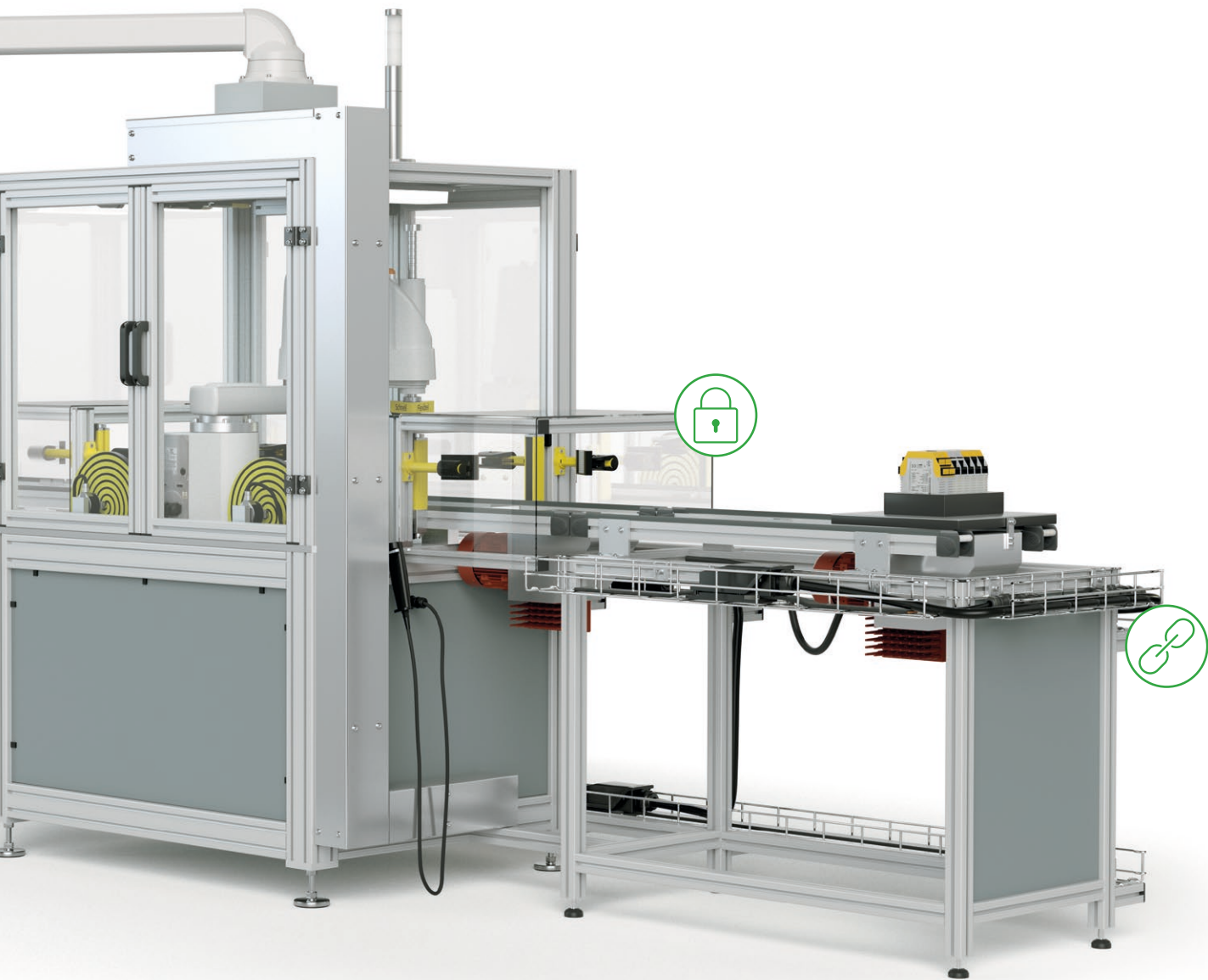

CUSTOMER SOLUTIONS

We merge our engineering and production know-how in cross-functional teams and will deliver product and service solutions or complete safety concepts that are tailored specifically to your requirements and needs.



TRAINING + SERVICE

Our commitment will not end with the commissioning of your plant. We are available at all times to provide advice concerning standards, regulations, and provisions, to train your staff in a wide variety of subjects, and to support the entire lifecycle of your machines from engineering to commissioning and maintenance.





SOFTWARE

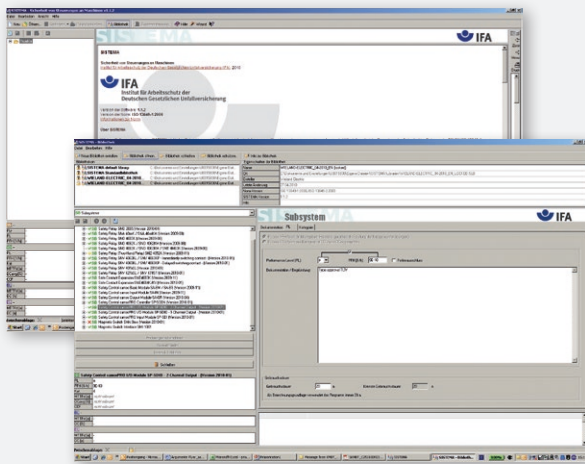

SISTEMA – SAFETY OF MACHINE CONTROLS

The SISTEMA software provides developers and testers of safety-related machine controls with comprehensive support when assessing safety within the scope of **DIN EN ISO 13849-1**. The name **SISTEMA** comes from the German "**SI**cherheit von **ST**eueringen an **MA**schinen" (safety of machine controls). The tool allows you to reproduce the structure of the safety-related control elements on the basis of the intended architectures and then enables an automated calculation of the reliability values at various levels of detail, including the performance level (PL) attained.

EPLAN – SUPPORT DURING CONFIGURATION

Support of automation projects naturally also includes EPLAN data and macros which can be very easily downloaded from the Wieland homepage at www.wieland-electric.com.

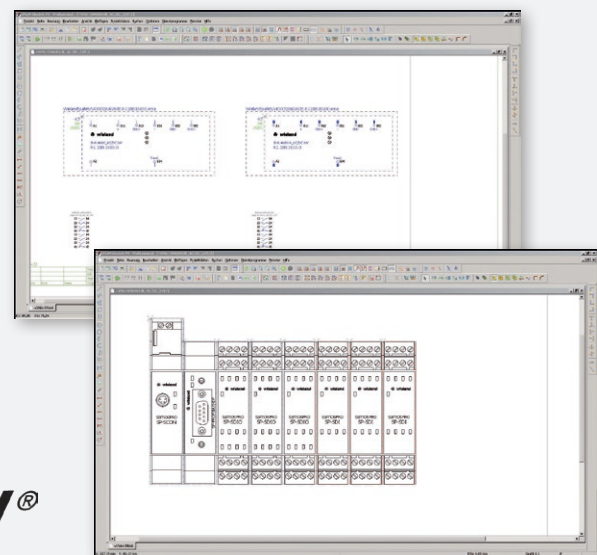

ePLAN®



TRAINING



Wieland Electric offers a range of workshops about the topic of machine safety.

The training covers hazard and risk analysis, definition of the necessary safety functions using the SISTEMA tool and support for selecting and implementing the necessary technical safety measures.

We provide our safety workshops and product training sessions both as in-house training and as a workshop at our modern Sales Center in Bamberg.



- Risk assessment and risk reduction in accordance with EN 12100
- Definition of technical safety measures
- Assessment of safety functions (SISTEMA)
- Product training
- Training for samos®PLAN 6

Simply contact us at **+49 951 9324 999**
or via e-mail at **safety@wieland-electric.com**



For further information see
the handbook of best practices
"Functional Safety",
Order No. 0424.1

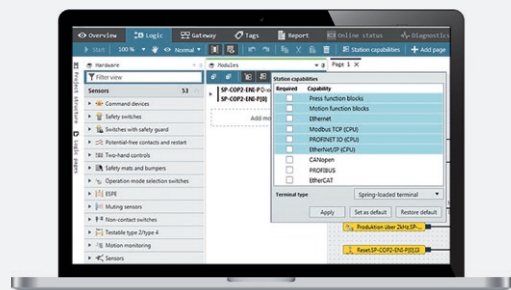

You can get the free
programming tool samos®PLAN 6
at **www.wieland-electric.com**
Service / Software



GLOSSARY

	Emergency stop monitoring Floating contacts		Single-channel input circuit 1 NC contact or semiconductor
	Protective gate monitoring Floating contacts		Two-channel input circuit 2 NC contacts or semiconductors
	Position monitoring Magnetic switch		Two-channel input circuit, antivalent 1 NO / 1 NC contacts or semiconductors
	Safety light grid / -light curtain acc. to EN 61496 BWS Type 4 / Type 2		Cross monitoring between two input circuits
	Two-hand control according to EN 574		Synchro-check between two input circuits
	Controlled Stop according to EN 60204-1 stop category 1		Safe Start Start command is accepted only when the input circuits are closed
	Standstill and motion monitoring		Combi-reset Automatic start possible after voltage failure, based on the risk analysis
	Safety shut-off mat monitoring (4-wire principle, short-circuiting)		Automatic Reset after application of the voltage and/or after safety request
	Valve position monitoring		Manual Reset in the case of a rising edge at the reset input
	Contact expansion		Reset button monitoring in the case of a falling edge at the reset input
	Machine building industry		Contacts (NO/NC) safe semiconductor outputs
	Press		Alarm contacts
	Elevator systems in accord. with EN 81-1		Safe changeover contacts
	Combustion plants according to EN 50156-1		Safe semi conductor outputs
	Process technology according to IEC 61511		Safe OFF-delay
	Finger protection		Safe ON-delay
	Hand protection		Monoflop for rapid tactile applications
	Arm protection		Reset of time lapse for OFF-delayed contacts
	Access protection		Expanded diagnostics
	Personal protection		





YOUR CONTACT PARTNERS.



INDUSTRIAL AUTOMATION,
ELECTROMECHANICS

Phone: **+49 951 9324-991**
E-mail: **AT.TS@wieland-electric.com**

BUILDING AND INSTALLATION
TECHNOLOGY

Phone: **+49 951 9324-996**
E-mail: **BIT.TS@wieland-electric.com**

INDUSTRIAL AUTOMATION, ELECTRONICS

Phone: **+49 951 9324-995**
E-mail: **AT.TS@wieland-electric.com**

SAFETY TECHNOLOGY

Phone: **+49 951 9324-999**
E-mail: **safety@wieland-electric.com**



WIELAND ON YOUTUBE
FIND OUT MORE ABOUT
OUR PRODUCTS



<https://www.youtube.com/user/WielandElectric>



OUR **SUBSIDIARIES**
AND OUR SALES PARTNER



Contact your local partner:
www.wieland-electric.com



ONLY ONE TIP AWAY.

OUR WIELAND E-SHOP
EVERY PRODUCT - ANY TIME

In our online store you will find all the information about our products, prices, and technical data. Order easily and conveniently online, and check availability.

<https://eshop.wieland-electric.com>

Scan QR code – view products in the E-SHOP.





wieland

HEADQUARTERS

Wieland Electric GmbH
Brennerstraße 10 – 14
96052 Bamberg · Germany

Phone +49 951 9324-0
Fax +49 951 9324-198
info@wieland-electric.com

0860.1 C 08/19

Represented in over 70 countries worldwide:

www.wieland-electric.com